



CAINTON

Change is a perpetual motion

DC Axial Fan

- Code Rule - p.1
- DC Axial Fan - pp. 2 - 191
- DC Outer Rotor Axial Fan - pp. 192 - 209
- DC Frameless Axial Fan - pp. 210 - 247

Code Rule

Fan Type	Fan imension (mm)		Voltage	Speed	Bearing	Connection	Function	Mold Model	IP Level
	Length	Thickness							
AXD: DC Axial Fan			V1: 110VAC	HX: Higher than Extreme	B: Ball Type	C: Connector	N1: FG	-Mold Model	-IP Level
OXD: DC Outer Rotor Axial Fan			V2: 220VAC	XH: Extremely High	S: Sleeve Type		N2: RD		
FXD: DC Frameless Axial Fan			V3: 380VAC	HH: Much Higher			N3: PWM		
			FV: Full Voltage	HR: Higher			N4: Voltage Control		
				H: High			N5: FG+PWM		
				M: Medium			N6: RD+PWM		
				L: Low			N7: FG+VC		
				LR: Lower			N8: RD+VC		
				LW: Much Lower					
				XL: Extremely Low					
				LX: Lower than Extreme					

DC Axial Fan

20x20x10mm

- Housing: Plastic (Flammability:UL94V-0)
- Impeller: Plastic (Flammability:UL94V-0)
- Bearing: Ball, Sleeve
- Certification: CE, RoHS
- Additional functions are optional



Model	Voltage	Current	Power	Speed	Air Flow		Pressure		Noise
	VDC	Amp	Watt	RPM	CFM	m3/min	mmH2O	inH2O	dB(A)
AXD2010V5L-K	5	0.06	0.3	10000	1.05	0.03	2.16	0.085	18.8
AXD2010V5M-K	5	0.08	0.4	12000	1.14	0.032	2.65	0.104	21.3
AXD2010V5H-K	5	0.13	0.65	14000	1.35	0.038	4.3	0.169	24.2
AXD2010V12L-K	12	0.03	0.36	10000	1.05	0.03	2.16	0.085	18.8
AXD2010V12M-K	12	0.05	0.6	12000	1.14	0.032	2.65	0.104	21.3
AXD2010V12H-K	12	0.08	0.96	14000	1.35	0.038	4.3	0.169	24.2

DC Axial Fan

20x20x10mm

- Dimension:

Unit: mm

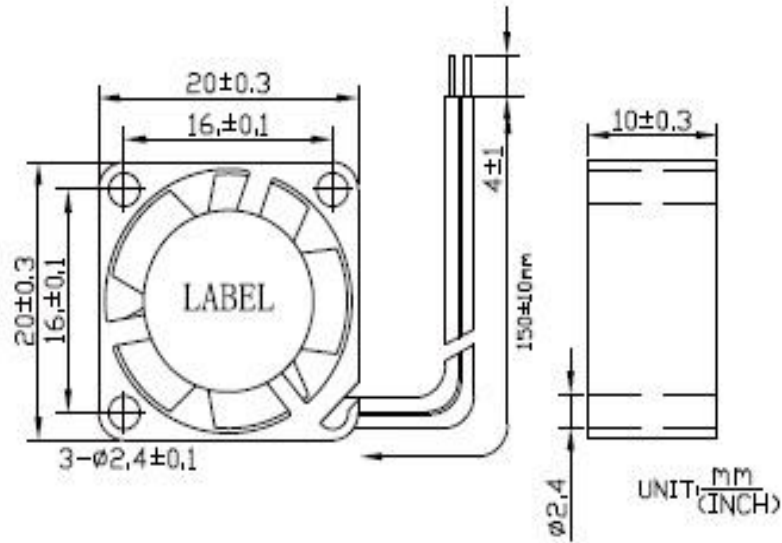

- Performance:

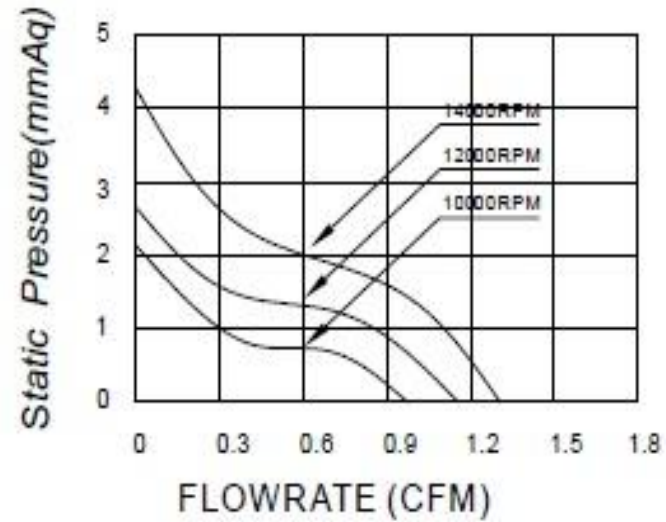

DC Axial Fan

25x25x10mm

- Housing: Plastic (Flammability:UL94V-0)
- Impeller: Plastic (Flammability:UL94V-0)
- Bearing: Ball, Sleeve
- Certification: CE, RoHS
- Additional functions are optional



Model	Voltage	Current	Power	Speed	Air Flow		Pressure		Noise
	VDC	Amp	Watt	RPM	CFM	m3/min	mmH2O	inH2O	dB(A)
AXD2510V5LR-K	5	0.14	0.72	8500	1.01	0.029	1.86	0.073	17.8
AXD2510V5L-K	5	0.17	0.84	10500	1.44	0.041	3.24	0.128	27.2
AXD2510V5M-K	5	0.19	0.96	12000	1.72	0.049	3.88	0.153	28.9
AXD2510V5H-K	5	0.22	1.08	13500	2.35	0.067	6.87	0.27	32.9
AXD2510V5HR-K	5	0.24	1.2	16000	2.63	0.074	8.73	0.344	37.6

DC Axial Fan

25x25x10mm

- Housing: Plastic (Flammability:UL94V-0)
- Impeller: Plastic (Flammability:UL94V-0)
- Bearing: Ball, Sleeve
- Certification: CE, RoHS
- Additional functions are optional



Model	Voltage	Current	Power	Speed	Air Flow		Pressure		Noise
	VDC	Amp	Watt	RPM	CFM	m3/min	mmH2O	inH2O	dB(A)
AXD2510V12LR-K	12	0.06	0.72	8500	1.01	0.029	1.86	0.073	17.8
AXD2510V12L-K	12	0.07	0.84	10500	1.44	0.041	3.24	0.128	27.2
AXD2510V12M-K	12	0.08	0.96	12000	1.72	0.049	3.88	0.153	28.9
AXD2510V12H-K	12	0.09	1.08	13500	2.35	0.067	6.87	0.27	32.9
AXD2510V12HR-K	12	0.1	1.2	16000	2.63	0.074	8.73	0.344	37.6

DC Axial Fan

25x25x10mm

- Dimension:

Unit: mm

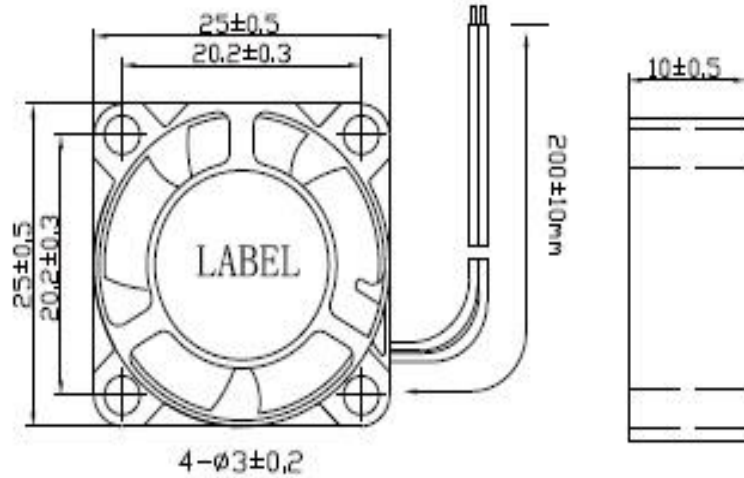

- Performance:

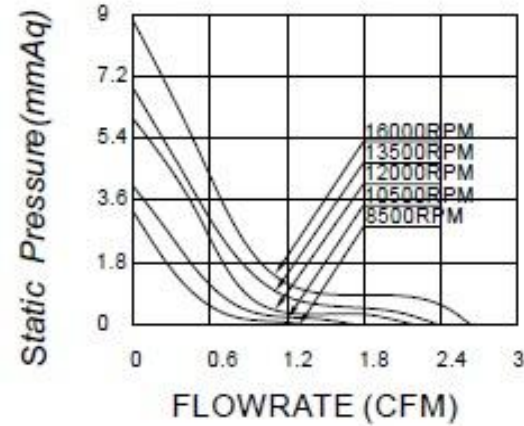

DC Axial Fan

30x30x10mm

- Housing: Plastic (Flammability:UL94V-0)
- Impeller: Plastic (Flammability:UL94V-0)
- Bearing: Ball, Sleeve
- Certification: CE, RoHS
- Additional functions are optional



Model	Voltage	Current	Power	Speed	Air Flow		Pressure		Noise
	VDC	Amp	Watt	RPM	CFM	m3/min	mmH2O	inH2O	dB(A)
AXD3010V5LR-K	5	0.14	0.72	5000	0.98	0.028	1.22	0.048	15.5
AXD3010V5L-K	5	0.17	0.84	7000	2.25	0.064	2.5	0.098	22.4
AXD3010V5M-K	5	0.19	0.96	9000	2.95	0.084	4.25	0.167	26.3
AXD3010V5H-K	5	0.22	1.08	11000	3.61	0.102	6.28	0.247	32
AXD3010V5HR-K	5	0.24	1.2	13000	4.25	0.12	8.25	0.325	34.9

DC Axial Fan

30x30x10mm

- Housing: Plastic (Flammability:UL94V-0)
- Impeller: Plastic (Flammability:UL94V-0)
- Bearing: Ball, Sleeve
- Certification: CE, RoHS
- Additional functions are optional



Model	Voltage	Current	Power	Speed	Air Flow		Pressure		Noise
	VDC	Amp	Watt	RPM	CFM	m3/min	mmH2O	inH2O	dB(A)
AXD3010V12LR-K	12	0.06	0.72	5000	0.98	0.028	1.22	0.048	15.5
AXD3010V12L-K	12	0.07	0.84	7000	2.25	0.064	2.5	0.098	22.4
AXD3010V12M-K	12	0.08	0.96	9000	2.95	0.084	4.25	0.167	26.3
AXD3010V12H-K	12	0.09	1.08	11000	3.61	0.102	6.28	0.247	32
AXD3010V12HR-K	12	0.1	1.2	13000	4.25	0.12	8.25	0.325	34.9

DC Axial Fan

30x30x10mm

- Dimension:

Unit: mm

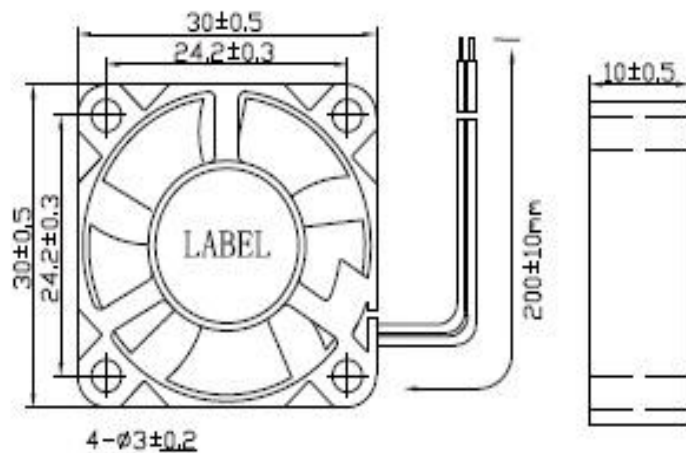

- Performance:

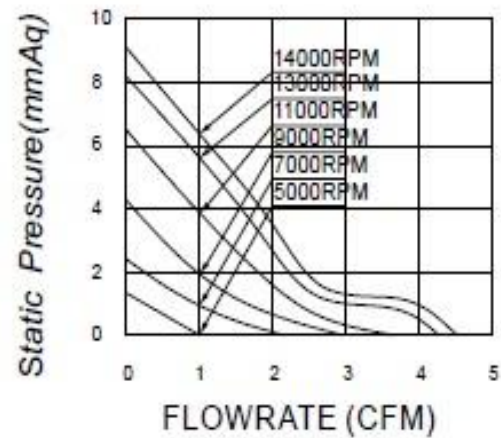

DC Axial Fan

Ø30x10mm - B Type

- Housing: Plastic (Flammability:UL94V-0)
- Impeller: Plastic (Flammability:UL94V-0)
- Bearing: Ball, Sleeve
- Certification: CE, RoHS
- Additional functions are optional



Model	Voltage	Current	Power	Speed	Air Flow		Pressure		Noise
	VDC	Amp	Watt	RPM	CFM	m3/min	mmH2O	inH2O	dB(A)
AXD3010V5LR-K2	5	0.14	0.72	5000	0.98	0.028	1.22	0.048	15.5
AXD3010V5L-K2	5	0.17	0.84	7000	2.25	0.064	2.5	0.098	22.4
AXD3010V5M-K2	5	0.19	0.96	9000	2.95	0.084	4.25	0.167	26.3
AXD3010V5H-K2	5	0.22	1.08	11000	0.361	0.102	6.28	0.247	32
AXD3010V5HR-K2	5	0.24	1.2	13000	4.25	0.12	8.25	0.325	34.9

DC Axial Fan

Ø30x10mm - B Type

- Housing: Plastic (Flammability:UL94V-0)
- Impeller: Plastic (Flammability:UL94V-0)
- Bearing: Ball, Sleeve
- Certification: CE, RoHS
- Additional functions are optional



Model	Voltage	Current	Power	Speed	Air Flow		Pressure		Noise
	VDC	Amp	Watt	RPM	CFM	m3/min	mmH2O	inH2O	dB(A)
AXD3010V12LR-K2	12	0.06	0.72	5000	0.98	0.028	1.22	0.048	15.5
AXD3010V12L-K2	12	0.07	0.84	7000	2.25	0.064	2.5	0.098	22.4
AXD3010V12M-K2	12	0.08	0.96	9000	2.95	0.084	4.25	0.167	26.3
AXD3010V12H-K2	12	0.09	1.08	11000	0.361	0.102	6.28	0.247	32
AXD3010V12HR-K2	12	0.1	1.2	13000	4.25	0.12	8.25	0.325	34.9

DC Axial Fan

Ø30x10mm - B Type

- Dimension:

Unit: mm

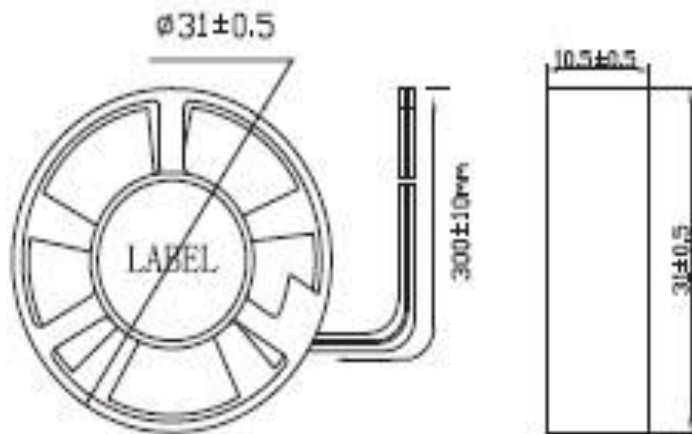

- Performance:

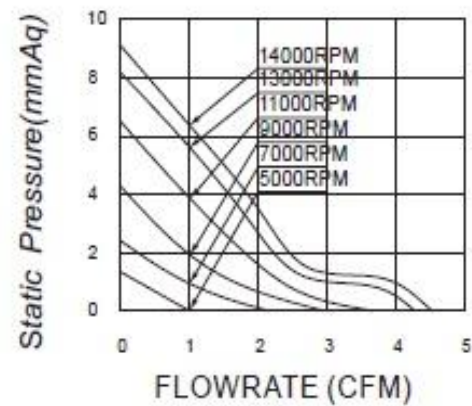

DC Axial Fan

35x35x10mm

- Housing: Plastic (Flammability:UL94V-0)
- Impeller: Plastic (Flammability:UL94V-0)
- Bearing: Ball, Sleeve
- Certification: CE, RoHS
- Additional functions are optional



Model	Voltage	Current	Power	Speed	Air Flow		Pressure		Noise
	VDC	Amp	Watt	RPM	CFM	m3/min	mmH2O	inH2O	dB(A)
AXD3510V5XL-K	5	0.1	0.5	7000	3.91	0.111	2.84	0.112	28
AXD3510V5LW-K	5	0.12	0.6	8000	4.5	0.128	3.51	0.138	31
AXD3510V5LR-K	5	0.13	0.65	9000	5	0.142	4.31	0.17	34.4
AXD3510V5L-K	5	0.14	0.7	10000	5.32	0.151	5.12	0.202	37.1

DC Axial Fan

35x35x10mm

- Housing: Plastic (Flammability:UL94V-0)
- Impeller: Plastic (Flammability:UL94V-0)
- Bearing: Ball, Sleeve
- Certification: CE, RoHS
- Additional functions are optional



Model	Voltage	Current	Power	Speed	Air Flow		Pressure		Noise
	VDC	Amp	Watt	RPM	CFM	m3/min	mmH2O	inH2O	dB(A)
AXD3510V5M-K	5	0.16	0.8	11000	6.06	0.171	6.11	0.241	39.4
AXD3510V5H-K	5	0.18	0.9	12000	6.39	0.182	6.77	0.267	41
AXD3510V5HR-K	5	0.2	1	13000	6.87	0.195	7.97	0.314	42.6
AXD3510V5HH-K	5	0.22	1.1	14000	7.41	0.211	8.74	0.344	44.7

DC Axial Fan

35x35x10mm

- Housing: Plastic (Flammability:UL94V-0)
- Impeller: Plastic (Flammability:UL94V-0)
- Bearing: Ball, Sleeve
- Certification: CE, RoHS
- Additional functions are optional



Model	Voltage	Current	Power	Speed	Air Flow		Pressure		Noise
	VDC	Amp	Watt	RPM	CFM	m3/min	mmH2O	inH2O	dB(A)
AXD3510V12XL-K	12	0.042	0.5	7000	3.91	0.111	2.84	0.112	28
AXD3510V12LW-K	12	0.05	0.6	8000	4.5	0.128	3.51	0.138	31
AXD3510V12LR-K	12	0.054	0.65	9000	5	0.142	4.31	0.17	34.4
AXD3510V12L-K	12	0.058	0.7	10000	5.32	0.151	5.12	0.202	37.1

DC Axial Fan

35x35x10mm

- Housing: Plastic (Flammability:UL94V-0)
- Impeller: Plastic (Flammability:UL94V-0)
- Bearing: Ball, Sleeve
- Certification: CE, RoHS
- Additional functions are optional



Model	Voltage	Current	Power	Speed	Air Flow		Pressure		Noise
	VDC	Amp	Watt	RPM	CFM	m3/min	mmH2O	inH2O	dB(A)
AXD3510V12M-K	12	0.067	0.8	11000	6.06	0.171	6.11	0.241	39.4
AXD3510V12H-K	12	0.075	0.9	12000	6.39	0.182	6.77	0.267	41
AXD3510V12HR-K	12	0.083	1	13000	6.87	0.195	7.97	0.314	42.6
AXD3510V12HH-K	12	0.092	1.1	14000	7.41	0.211	8.74	0.344	44.7

DC Axial Fan

35x35x10mm

- Dimension:

Unit: mm

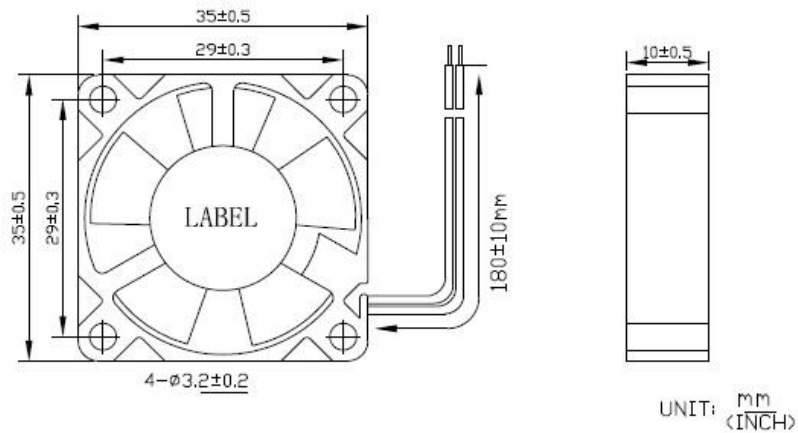

- Performance:

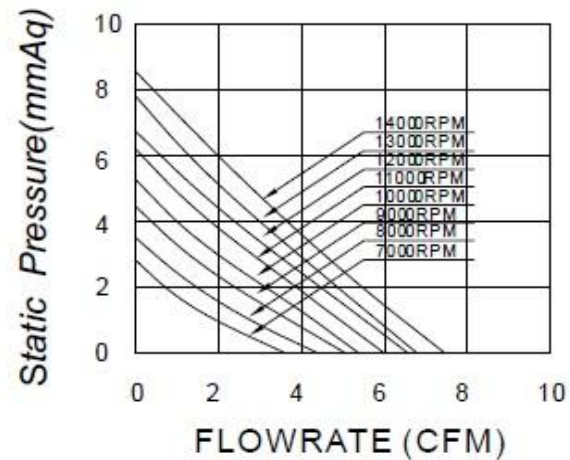

DC Axial Fan

Ø35x11mm - B Type

- Housing: Plastic (Flammability:UL94V-0)
- Impeller: Plastic (Flammability:UL94V-0)
- Bearing: Ball, Sleeve
- Certification: CE, RoHS
- Additional functions are optional



Model	Voltage	Current	Power	Speed	Air Flow		Pressure		Noise
	VDC	Amp	Watt	RPM	CFM	m3/min	mmH2O	inH2O	dB(A)
AXD3511V5XL-K2	5	0.1	0.5	7000	3.91	0.111	2.84	0.112	28
AXD3511V5LW-K2	5	0.12	0.6	8000	4.5	0.128	3.51	0.138	31
AXD3511V5LR-K2	5	0.13	0.65	9000	5	0.142	4.31	0.17	34.4
AXD3511V5L-K2	5	0.14	0.7	10000	5.32	0.151	5.12	0.202	37.1

DC Axial Fan

Ø35x11mm - B Type

- Housing: Plastic (Flammability:UL94V-0)
- Impeller: Plastic (Flammability:UL94V-0)
- Bearing: Ball, Sleeve
- Certification: CE, RoHS
- Additional functions are optional



Model	Voltage	Current	Power	Speed	Air Flow		Pressure		Noise
	VDC	Amp	Watt	RPM	CFM	m3/min	mmH2O	inH2O	dB(A)
AXD3511V5M-K2	5	0.16	0.8	11000	6.06	0.171	6.11	0.241	39.4
AXD3511V5H-K2	5	0.18	0.9	12000	6.39	0.182	6.77	3267	41
AXD3511V5HR-K2	5	0.2	1	13000	6.87	0.195	7.97	0.314	42.6
AXD3511V5HH-K2	5	0.22	1.1	14000	7.41	0.211	8.74	0.344	44.7

DC Axial Fan

Ø35x11mm - B Type

- Housing: Plastic (Flammability:UL94V-0)
- Impeller: Plastic (Flammability:UL94V-0)
- Bearing: Ball, Sleeve
- Certification: CE, RoHS
- Additional functions are optional



Model	Voltage	Current	Power	Speed	Air Flow		Pressure		Noise
	VDC	Amp	Watt	RPM	CFM	m3/min	mmH2O	inH2O	dB(A)
AXD3511V12XL-K2	12	0.042	0.5	7000	3.91	0.111	2.84	0.112	28
AXD3511V12LW-K2	12	0.05	0.6	8000	4.5	0.128	3.51	0.138	31
AXD3511V12LR-K2	12	0.054	0.65	9000	5	0.142	4.31	0.17	34.4
AXD3511V12L-K2	12	0.058	0.7	10000	5.32	0.151	5.12	0.202	37.1

DC Axial Fan

Ø35x11mm - B Type

- Housing: Plastic (Flammability:UL94V-0)
- Impeller: Plastic (Flammability:UL94V-0)
- Bearing: Ball, Sleeve
- Certification: CE, RoHS
- Additional functions are optional



Model	Voltage	Current	Power	Speed	Air Flow		Pressure		Noise
	VDC	Amp	Watt	RPM	CFM	m3/min	mmH2O	inH2O	dB(A)
AXD3511V12M-K2	12	0.067	0.8	11000	6.06	0.171	6.11	0.241	39.4
AXD3511V12H-K2	12	0.075	0.9	12000	6.39	0.182	6.77	0.267	41
AXD3511V12HR-K2	12	0.083	1	13000	6.87	0.195	7.97	0.314	42.6
AXD3511V12HH-K2	12	0.092	1.1	14000	7.41	0.211	8.74	0.344	44.7

DC Axial Fan

Ø35x11mm - B Type

- Dimension:
Unit: mm

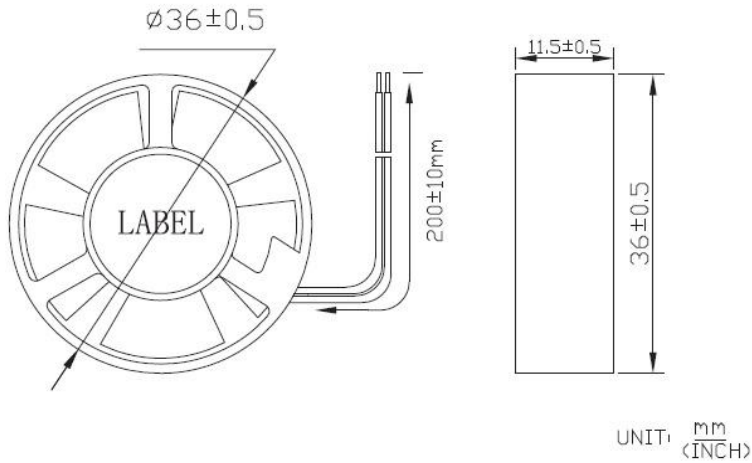

- Performance:

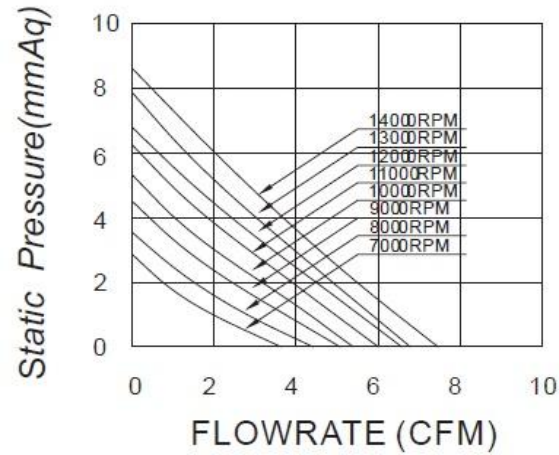

DC Axial Fan

38x38x28mm

- Housing: Plastic (Flammability:UL94V-0)
- Impeller: Plastic (Flammability:UL94V-0)
- Bearing: Ball
- Certification: CE, RoHS
- Additional functions are optional

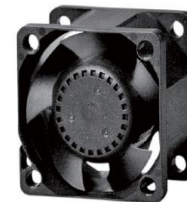

Model	Voltage	Current	Power	Speed	Air Flow		Pressure		Noise
	VDC	Amp	Watt	RPM	CFM	m3/min	mmH2O	inH2O	dB(A)
AXD3828V12H-K	12	0.52	6.24	20000	23	0.651	56.64	2.23	59

DC Axial Fan

38x38x28mm

- Dimension:

Unit: mm

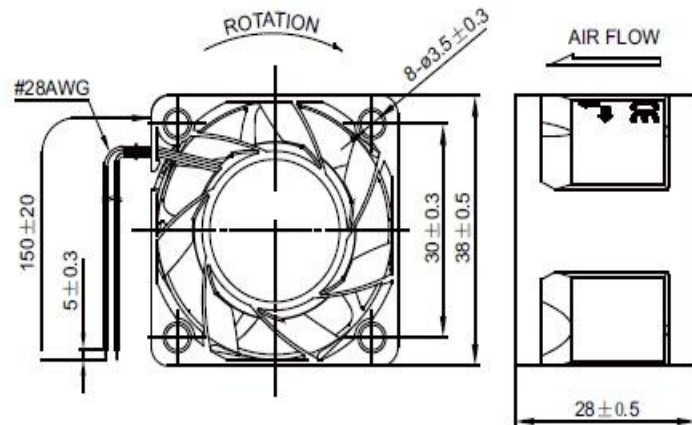

- Performance:

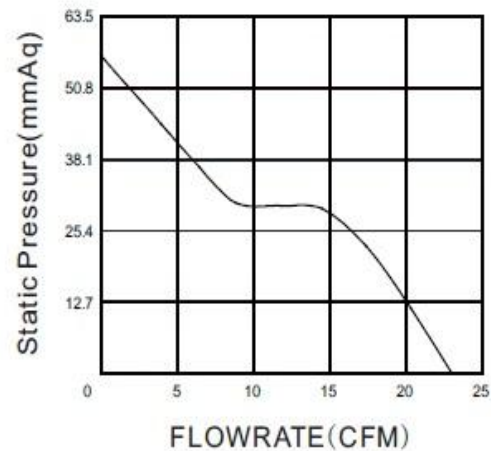

DC Axial Fan

40x40x10mm - C Type

- Housing: Plastic (Flammability:UL94V-0)
- Impeller: Plastic (Flammability:UL94V-0)
- Bearing: Ball, Sleeve
- Certification: CE, RoHS
- Additional functions are optional



Model	Voltage	Current	Power	Speed	Air Flow		Pressure		Noise
	VDC	Amp	Watt	RPM	CFM	m3/min	mmH2O	inH2O	dB(A)
AXD4010V5LW-K3	5	0.072	0.36	4500	4.06	0.115	1.73	0.069	25.1
AXD4010V5LR-K3	5	0.096	0.48	5000	4.51	0.128	2.12	0.083	26.2
AXD4010V5L-K3	5	0.12	0.6	5500	5.34	0.151	2.68	0.106	28.1
AXD4010V5M-K3	5	0.144	0.72	6000	5.84	0.165	3.29	0.13	29.6
AXD4010V5H-K3	5	0.168	0.84	6500	6.23	0.176	3.6	0.142	31.2
AXD4010V5HR-K3	5	0.192	0.96	7000	6.68	0.189	4.02	0.158	33.7

DC Axial Fan

40x40x10mm - C Type

- Housing: Plastic (Flammability:UL94V-0)
- Impeller: Plastic (Flammability:UL94V-0)
- Bearing: Ball, Sleeve
- Certification: CE, RoHS
- Additional functions are optional



Model	Voltage	Current	Power	Speed	Air Flow		Pressure		Noise
	VDC	Amp	Watt	RPM	CFM	m3/min	mmH2O	inH2O	dB(A)
AXD4010V12LW-K3	12	0.03	0.36	4500	4.06	0.115	1.73	0.069	25.1
AXD4010V12LR-K3	12	0.04	0.48	5000	4.51	0.128	2.12	0.083	26.2
AXD4010V12L-K3	12	0.05	0.6	5500	5.34	0.151	2.68	0.106	28.1
AXD4010V12M-K3	12	0.06	0.72	6000	5.84	0.165	3.29	0.13	29.6
AXD4010V12H-K3	12	0.07	0.84	6500	6.23	0.176	3.6	0.142	31.2
AXD4010V12HR-K3	12	0.08	0.96	7000	6.68	0.189	4.02	0.158	33.7

DC Axial Fan

40x40x10mm - C Type

- Dimension:

Unit: mm

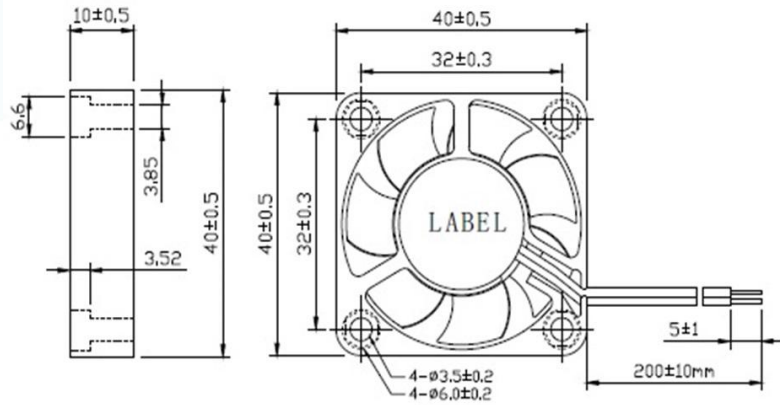

- Performance:

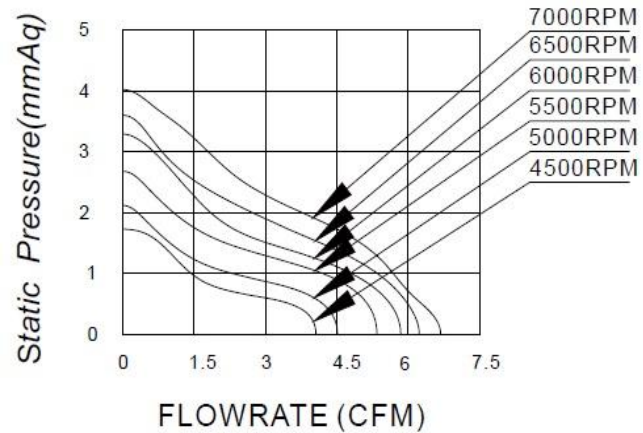

DC Axial Fan

40x40x15mm

- Housing: Plastic (Flammability:UL94V-0)
- Impeller: Plastic (Flammability:UL94V-0)
- Bearing: Ball, Sleeve
- Certification: CE, RoHS
- Additional functions are optional



Model	Voltage	Current	Power	Speed	Air Flow		Pressure		Noise
	VDC	Amp	Watt	RPM	CFM	m3/min	mmH2O	inH2O	dB(A)
AXD4015V5LW-K	5	0.15	0.75	5000	6.5	0.184	3.67	0.144	18.5
AXD4015V5LR-K	5	0.22	1.1	6000	8.12	0.23	5.12	0.202	24.5
AXD4015V5L-K	5	0.24	1.2	7000	9.46	0.268	6.92	0.272	28.5
AXD4015V5M-K	5	0.32	1.6	8300	11.48	0.325	9.13	0.359	32
AXD4010V5H-K	5	0.38	1.9	9500	13	0.368	11.66	0.459	36.5

DC Axial Fan

40x40x15mm

- Housing: Plastic (Flammability:UL94V-0)
- Impeller: Plastic (Flammability:UL94V-0)
- Bearing: Ball, Sleeve
- Certification: CE, RoHS
- Additional functions are optional



Model	Voltage	Current	Power	Speed	Air Flow		Pressure		Noise
	VDC	Amp	Watt	RPM	CFM	m3/min	mmH2O	inH2O	dB(A)
AXD4015V12LW-K	12	0.06	0.72	5000	6.5	0.184	3.67	0.144	18.5
AXD401512LR-K	12	0.09	1.08	6000	8.12	0.23	5.12	0.202	24.5
AXD4015V12L-K	12	0.1	1.2	7000	9.46	0.268	6.92	0.272	28.5
AXD4015V12M-K	12	0.13	1.56	8300	11.48	0.325	9.13	0.359	32
AXD4015V12H-K	12	0.16	1.92	9500	13	0.368	11.66	0.459	36.5
AXD4015V12HR-K	12	0.25	3	11000	14.83	0.42	15.26	0.601	41.5

DC Axial Fan

40x40x15mm

- Housing: Plastic (Flammability:UL94V-0)
- Impeller: Plastic (Flammability:UL94V-0)
- Bearing: Ball, Sleeve
- Certification: CE, RoHS
- Additional functions are optional



Model	Voltage	Current	Power	Speed	Air Flow		Pressure		Noise
	VDC	Amp	Watt	RPM	CFM	m3/min	mmH2O	inH2O	dB(A)
AXD4015V24LW-K	24	0.05	1.2	5000	6.5	0.184	3.67	0.144	18.5
AXD4015V24LR-K	24	0.06	1.44	6000	8.12	0.23	5.12	0.202	24.5
AXD4015V24L-K	24	0.08	1.92	7000	9.46	0.268	6.92	0.272	28.5
AXD4015V24M-K	24	0.09	2.16	8300	11.48	0.325	9.13	0.359	32
AXD4015V24H-K	24	0.1	2.4	9500	13	0.368	11.66	0.459	36.5
AXD4015V24HR-K	24	0.12	2.88	11000	14.83	0.42	15.26	0.601	41.5

DC Axial Fan

40x40x15mm

- Dimension:

Unit: mm

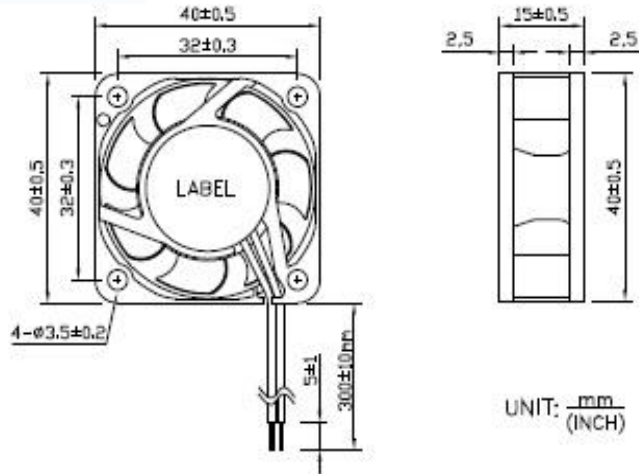

- Performance:

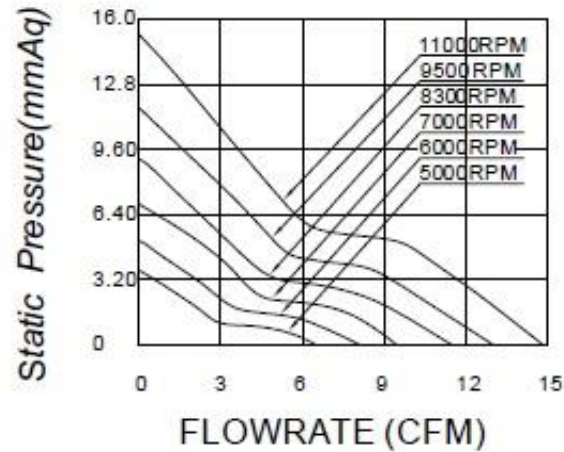

DC Axial Fan

40x40x20mm - C Type

- Housing: Plastic (Flammability:UL94V-0)
- Impeller: Plastic (Flammability:UL94V-0)
- Bearing: Ball
- Certification: CE, RoHS
- Additional functions are optional



Model	Voltage	Current	Power	Speed	Air Flow		Pressure		Noise
	VDC	Amp	Watt	RPM	CFM	m3/min	mmH2O	inH2O	dB(A)
AXD4020V12LR-K3	12	0.43	5.16	12000	16.6	0.47	20.7	0.82	53.2
AXD4020V12L-K3	12	0.55	6.6	14000	19.6	0.56	27.1	1.07	53.5
AXD4020V12M-K3	12	0.67	8.04	16000	22.2	0.63	35	1.38	55.6
AXD4020V12H-K3	12	0.85	10.2	18000	24.8	0.71	43.8	1.73	57.7
AXD4020V12HR-K3	12	1.3	15.6	20000	29.5	0.84	59.2	2.33	58.1

DC Axial Fan

40x40x20mm - C Type

- Housing: Plastic (Flammability:UL94V-0)
- Impeller: Plastic (Flammability:UL94V-0)
- Bearing: Ball, Sleeve
- Certification: CE, RoHS
- Additional functions are optional



Model	Voltage	Current	Power	Speed	Air Flow		Pressure		Noise
	VDC	Amp	Watt	RPM	CFM	m3/min	mmH2O	inH2O	dB(A)
AXD4020V24LR-K3	24	0.21	5.16	12000	16.6	0.47	20.7	0.82	53.2
AXD4020V24L-K3	24	0.27	6.6	14000	19.6	0.56	27.1	1.07	53.5
AXD4020V24M-K3	24	0.34	8.04	16000	22.2	0.63	35	1.38	55.6
AXD4020V24H-K3	24	0.4	10.2	18000	24.8	0.71	43.8	1.73	57.7
AXD4020V24HR-K3	24	0.65	15.6	20000	29.5	0.84	59.2	2.33	58.1

DC Axial Fan

40x40x20mm - C Type

- Dimension:

Unit: mm

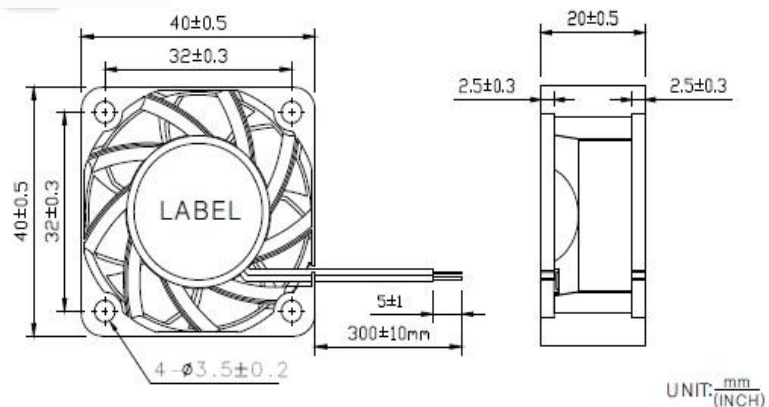

- Performance:

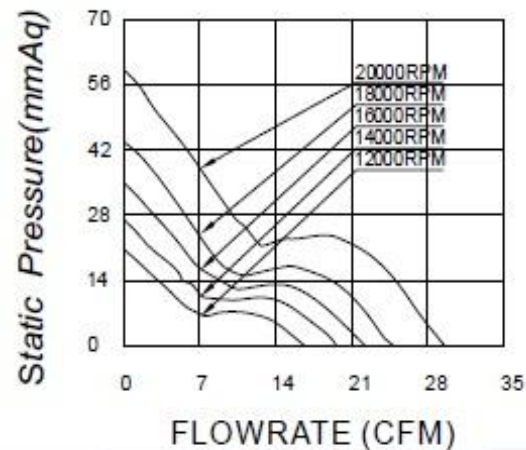

DC Axial Fan

45x45x10mm - A Type

- Housing: Plastic (Flammability:UL94V-0)
- Impeller: Plastic (Flammability:UL94V-0)
- Bearing: Ball, Sleeve
- Certification: CE, RoHS
- Additional functions are optional



Model	Voltage	Current	Power	Speed	Air Flow		Pressure		Noise
	VDC	Amp	Watt	RPM	CFM	m3/min	mmH2O	inH2O	dB(A)
AXD4510V5XL-K	5	0.1	0.48	4000	5.19	0.146	1.61	0.063	24.3
AXD4510V5LW-K	5	0.12	0.6	4500	5.41	0.153	2.06	0.081	28.1
AXD4510V5LR-K	5	0.144	0.72	5000	6.46	0.183	2.5	0.098	30.2
AXD4510V5L-K	5	0.192	0.96	5500	6.88	0.195	2.92	0.115	33.9
AXD4510V5M-K	5	0.24	1.2	6000	7.87	0.223	3.69	0.145	36.3
AXD4510V5H-K	5	0.264	1.32	6500	8.24	0.233	3.89	0.153	37.3
AXD4510V5HR-K	5	0.31	1.56	7000	8.85	0.25	4.5	0.177	39.3

DC Axial Fan

45x45x10mm - A Type

- Housing: Plastic (Flammability:UL94V-0)
- Impeller: Plastic (Flammability:UL94V-0)
- Bearing: Ball, Sleeve
- Certification: CE, RoHS
- Additional functions are optional



Model	Voltage	Current	Power	Speed	Air Flow		Pressure		Noise
	VDC	Amp	Watt	RPM	CFM	m3/min	mmH2O	inH2O	dB(A)
AXD4510V12XL-K	12	0.04	0.48	4000	5.19	0.146	1.61	0.063	24.3
AXD4510V12LW-K	12	0.05	0.6	4500	5.41	0.153	2.06	0.081	28.1
AXD4510V12LR-K	12	0.06	0.72	5000	6.46	0.183	2.5	0.098	30.2
AXD4510V12L-K	12	0.08	0.96	5500	6.88	0.195	2.92	0.115	33.9
AXD4510V12M-K	12	0.1	1.2	6000	7.87	0.223	3.69	0.145	36.3
AXD4510V12H-K	12	0.11	1.32	6500	8.24	0.233	3.89	0.153	37.3
AXD4510V12HR-K	12	0.13	1.56	7000	8.85	0.25	4.5	0.177	39.3

DC Axial Fan

45x45x10mm - A Type

- Dimension:

Unit: mm

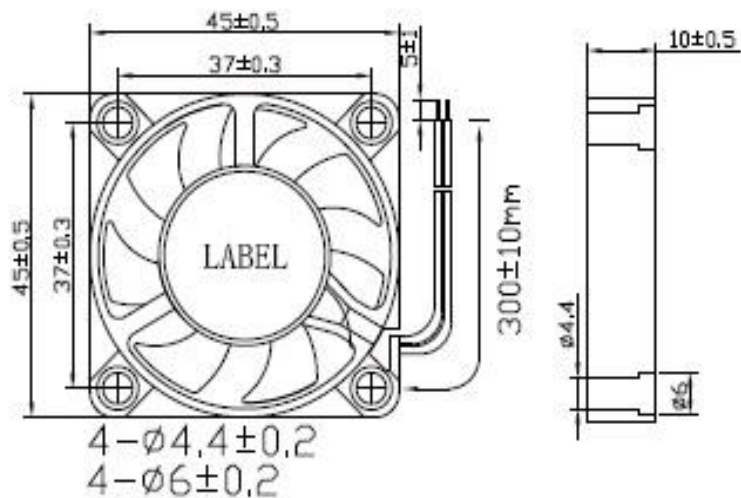

- Performance:

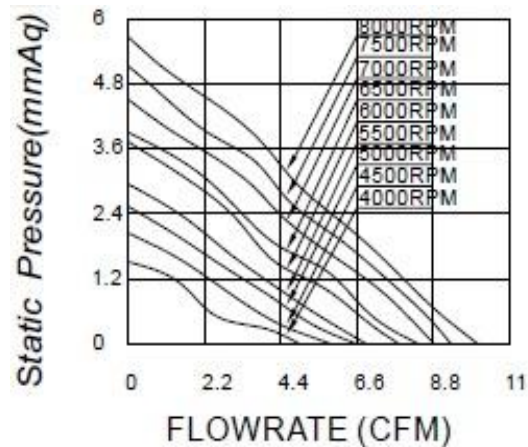

DC Axial Fan

40x40x28mm - C Type

- Housing: Plastic (Flammability:UL94V-0)
- Impeller: Plastic (Flammability:UL94V-0)
- Bearing: Ball
- Certification: CE, RoHS
- Additional functions are optional



Model	Voltage	Current	Power	Speed	Air Flow		Pressure		Noise
	VDC	Amp	Watt	RPM	CFM	m3/min	mmH2O	inH2O	dB(A)
AXD4028V12H-K3	12	0.9	10.8	20000	26.6	0.753	57.6	2.269	61.3
AXD4028V12HR-K3	12	1.2	14.4	22000	29.7	0.84	71.3	2.808	64.5
AXD4028V24H-K3	24	0.45	10.8	20000	26.6	0.753	57.6	2.269	61.3
AXD4028V24HR-K3	24	0.6	14.4	22000	29.7	0.84	71.3	2.808	64.5

DC Axial Fan

40x40x28mm - C Type

- Dimension:

Unit: mm

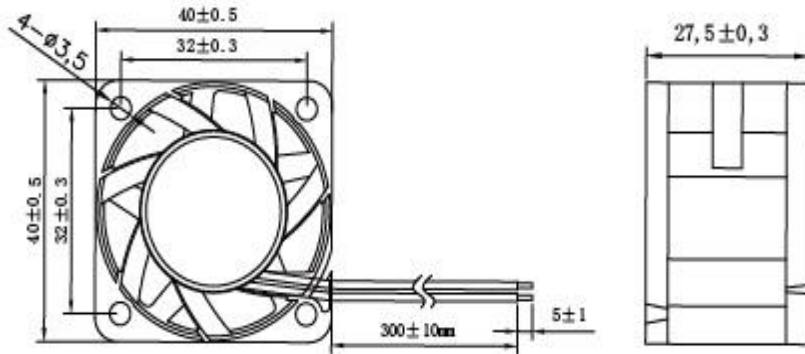

- Performance:

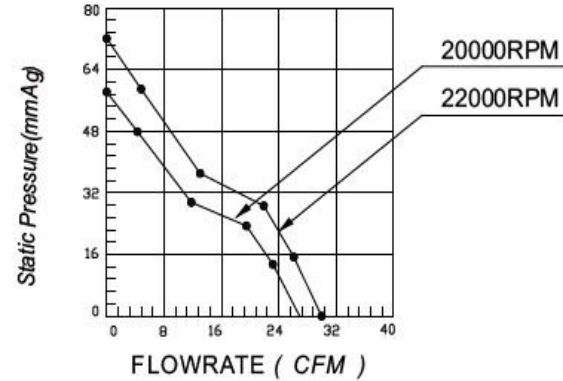

DC Axial Fan

40x40x28mm - D Type

- Housing: Plastic (Flammability:UL94V-0)
- Impeller: Plastic (Flammability:UL94V-0)
- Bearing: Ball
- Certification: CE, RoHS
- Additional functions are optional



Model	Voltage	Current	Power	Speed	Air Flow		Pressure		Noise
	VDC	Amp	Watt	RPM	CFM	m3/min	mmH2O	inH2O	dB(A)
AXD4028V12H-K4	12	2.8	33.6	32000	38.5	1.09	163.5	6.44	72.2
AXD4028V24H-K4	24	1.4	33.6	32000	38.5	1.09	163.5	6.44	72.2

DC Axial Fan

40x40x28mm - D Type

- Dimension:

Unit: mm

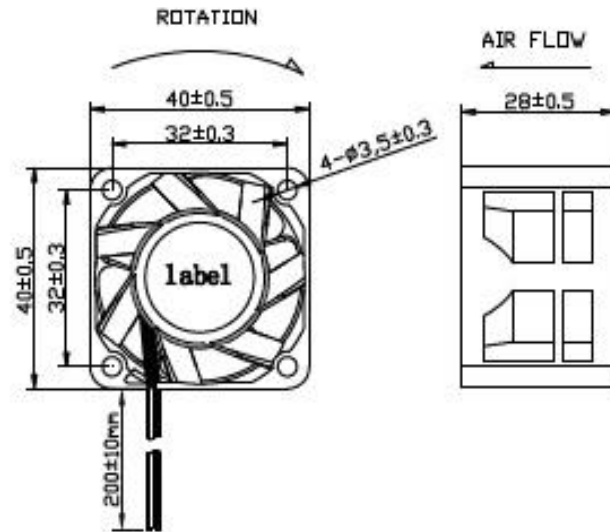

- Performance:

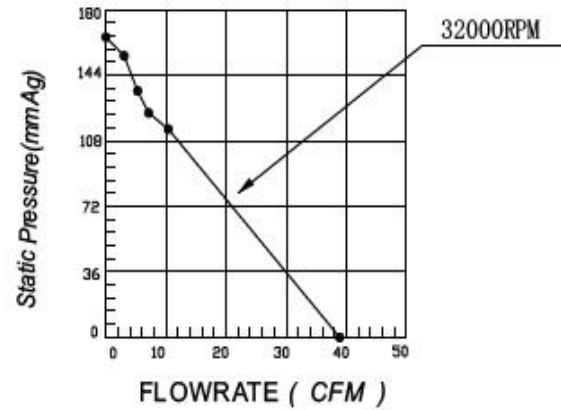

DC Axial Fan

50x50x10mm

- Housing: Plastic (Flammability:UL94V-0)
- Impeller: Plastic (Flammability:UL94V-0)
- Bearing: Ball, Sleeve
- Certification: CE, RoHS
- Additional functions are optional



Model	Voltage	Current	Power	Speed	Air Flow		Pressure		Noise
	VDC	Amp	Watt	RPM	CFM	m3/min	mmH2O	inH2O	dB(A)
AXD5010V5LW-K	5	0.072	0.36	4000	8.14	0.231	1.65	0.065	26.8
AXD5010V5LR-K	5	0.096	0.48	4500	9.09	0.257	2.05	0.081	29.7
AXD5010V5L-K	5	0.12	0.6	5000	10.5	0.3	2.58	0.102	31
AXD5010V5M-K	5	0.144	0.72	5500	10.8	0.308	2.84	0.112	33.5
AXD5010V5H-K	5	0.168	0.84	6000	12.1	0.345	3.34	0.131	34.2
AXD5010V5HR-K	5	0.19	0.96	6500	13.4	0.38	3.85	0.152	36.8

DC Axial Fan

50x50x10mm

- Housing: Plastic (Flammability:UL94V-0)
- Impeller: Plastic (Flammability:UL94V-0)
- Bearing: Ball, Sleeve
- Certification: CE, RoHS
- Additional functions are optional



Model	Voltage	Current	Power	Speed	Air Flow		Pressure		Noise
	VDC	Amp	Watt	RPM	CFM	m3/min	mmH2O	inH2O	dB(A)
AXD5010V12LW-K	12	0.03	0.36	4000	8.14	0.231	1.65	0.065	26.8
AXD5010V12LR-K	12	0.04	0.48	4500	9.09	0.257	2.05	0.081	29.7
AXD5010V12L-K	12	0.05	0.6	5000	10.5	0.3	2.58	0.102	31
AXD5010V12M-K	12	0.06	0.72	5500	10.8	0.308	2.84	0.112	33.5
AXD5010V12H-K	12	0.07	0.84	6000	12.1	0.345	3.34	0.131	34.2
AXD5010V12HR-K	12	0.08	0.096	6500	13.4	0.38	3.85	0.152	36.8

DC Axial Fan

50x50x10mm

- Dimension:

Unit: mm

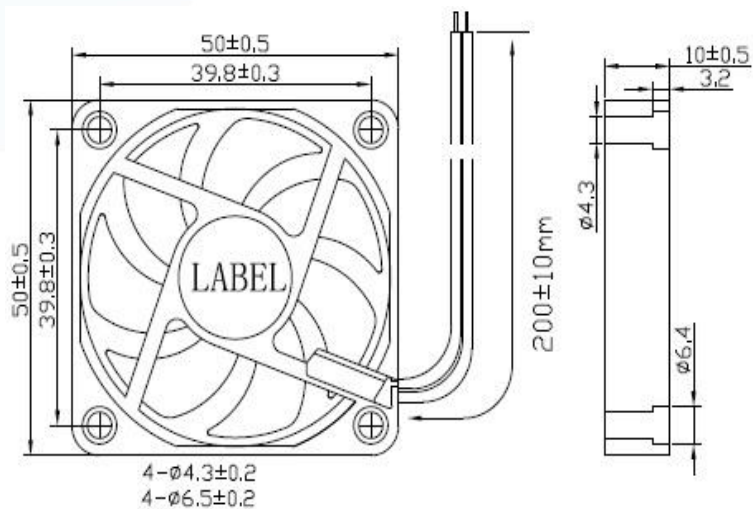

- Performance:

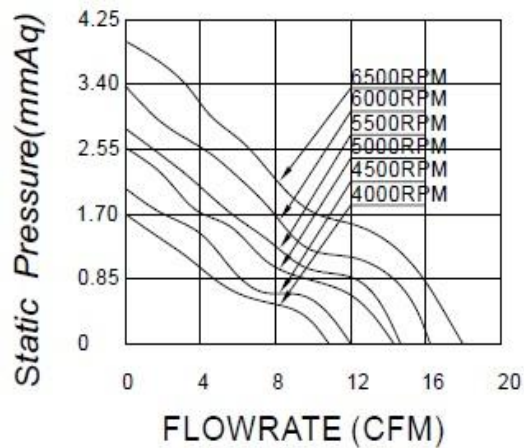

DC Axial Fan

50x50x15mm

- Housing: Plastic (Flammability:UL94V-0)
- Impeller: Plastic (Flammability:UL94V-0)
- Bearing: Ball, Sleeve
- Certification: CE, RoHS
- Additional functions are optional



Model	Voltage	Current	Power	Speed	Air Flow		Pressure		Noise
	VDC	Amp	Watt	RPM	CFM	m3/min	mmH2O	inH2O	dB(A)
AXD5015V5XL-K	5	0.12	0.6	3500	8.52	0.241	2.06	0.081	24.1
AXD5015V5LW-K	5	0.144	0.72	4000	9.77	0.277	2.76	0.109	28.1
AXD5015V5LR-K	5	0.192	0.96	4500	10.8	0.308	3.37	0.133	31.2
AXD5015V5L-K	5	0.24	1.2	5000	12.1	0.343	4.04	0.159	33.9

DC Axial Fan

50x50x15mm

- Housing: Plastic (Flammability:UL94V-0)
- Impeller: Plastic (Flammability:UL94V-0)
- Bearing: Ball, Sleeve
- Certification: CE, RoHS
- Additional functions are optional



Model	Voltage	Current	Power	Speed	Air Flow		Pressure		Noise
	VDC	Amp	Watt	RPM	CFM	m3/min	mmH2O	inH2O	dB(A)
AXD5015V12XL-K	12	0.05	0.6	3500	8.52	0.241	2.06	0.081	24.1
AXD5015V12LW-K	12	0.06	0.72	4000	9.77	0.277	2.76	0.109	28.1
AXD5015V12LR-K	12	0.08	0.96	4500	10.8	0.308	3.37	0.133	31.2
AXD5015V12L-K	12	0.1	1.2	5000	12.1	0.343	4.04	0.159	33.9
AXD5015V12M-K	12	0.014	1.68	5500	13.4	0.38	4.84	0.191	37.7
AXD5015V12H-K	12	0.18	2.16	6000	14.6	0.416	5.76	0.228	39.4
AXD5015V12HR-K	12	0.24	2.88	6500	15.8	0.449	6.68	0.263	41.2
AXD5015V12HH-K	12	0.3	3.6	7500	18.3	0.519	8.68	0.342	46.1

DC Axial Fan

50x50x15mm

- Housing: Plastic (Flammability:UL94V-0)
- Impeller: Plastic (Flammability:UL94V-0)
- Bearing: Ball, Sleeve
- Certification: CE, RoHS
- Additional functions are optional



Model	Voltage	Current	Power	Speed	Air Flow		Pressure		Noise
	VDC	Amp	Watt	RPM	CFM	m3/min	mmH2O	inH2O	dB(A)
AXD5015V24LR-K	24	0.04	0.96	4500	10.8	0.308	3.37	0.133	31.2
AXD5015V24L-K	24	0.05	1.2	5000	12.1	0.343	4.04	0.159	33.9
AXD5015V24M-K	24	0.07	1.68	5500	13.4	0.38	4.84	0.191	37.7
AXD5015V24H-K	24	0.09	2.16	6000	14.6	0.416	5.76	0.228	39.4
AXD5015V24HR-K	24	0.12	2.88	6500	15.8	0.449	6.68	0.263	41.2
AXD5015V24HH-K	24	0.15	3.6	7500	18.3	0.519	8.68	0.342	46.1

DC Axial Fan

50x50x15mm

- Dimension:

Unit: mm

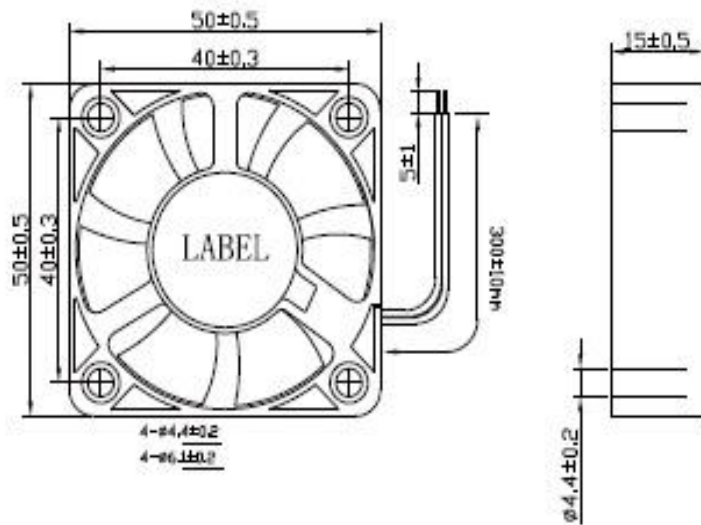

- Performance:

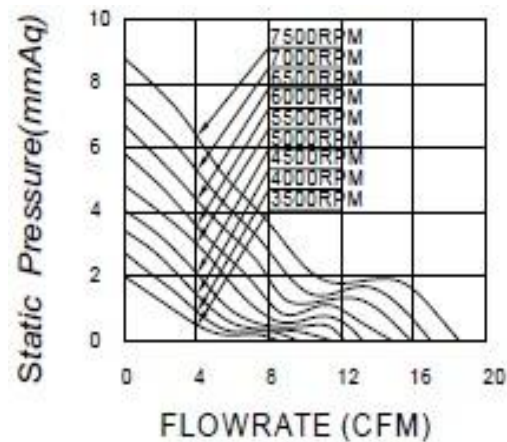

DC Axial Fan

50x50x20mm

- Housing: Plastic (Flammability:UL94V-0)
- Impeller: Plastic (Flammability:UL94V-0)
- Bearing: Ball, Sleeve
- Certification: CE, RoHS
- Additional functions are optional



Model	Voltage	Current	Power	Speed	Air Flow		Pressure		Noise
	VDC	Amp	Watt	RPM	CFM	m3/min	mmH2O	inH2O	dB(A)
AXD5020V12XL-K	12	0.06	0.72	3000	8.85	0.251	1.53	0.06	22.3
AXD5020V12LW-K	12	0.08	0.96	3500	10.30	0.283	1.99	0.078	24.2
AXD5020V12LR-K	12	0.1	1.2	4000	11.90	0.338	2.57	0.101	26
AXD5020V12L-K	12	0.14	1.68	4500	13.40	0.38	3.15	0.124	30.2
AXD5020V12M-K	12	0.18	2.16	5000	14.70	0.417	3.84	0.151	34.5
AXD5020V12H-K	12	0.22	2.64	5500	16.60	0.471	4.69	0.185	36.8
AXD5020V12HR-K	12	0.24	2.88	6000	18.40	0.521	5.81	0.229	40.6
AXD5020V12HH-K	12	0.28	3.36	6500	20.10	0.57	6.71	0.264	41.4

DC Axial Fan

50x50x20mm

- Housing: Plastic (Flammability:UL94V-0)
- Impeller: Plastic (Flammability:UL94V-0)
- Bearing: Ball, Sleeve
- Certification: CE, RoHS
- Additional functions are optional



Model	Voltage	Current	Power	Speed	Air Flow		Pressure		Noise
	VDC	Amp	Watt	RPM	CFM	m3/min	mmH2O	inH2O	dB(A)
AXD5020V24XL-K	24	0.03	0.72	3000	8.85	0.251	1.53	0.06	22.3
AXD5020V24LW-K	24	0.04	0.96	3500	10.30	0.283	1.99	0.078	24.2
AXD5020V24LR-K	24	0.05	1.2	4000	11.90	0.338	2.57	0.101	26
AXD5020V24L-K	24	0.07	1.68	4500	13.40	0.38	3.15	0.124	30.2
AXD5020V24M-K	24	0.09	2.16	5000	14.70	0.417	3.84	0.151	34.5
AXD5020V24H-K	24	0.11	2.64	5500	16.60	0.471	4.69	0.185	36.8
AXD5020V24HR-K	24	0.12	2.88	6000	18.40	0.521	5.81	0.229	40.6
AXD5020V24HH-K	24	0.14	3.36	6500	20.10	0.57	6.71	0.264	41.4

DC Axial Fan

50x50x20mm

- Dimension:

Unit: mm

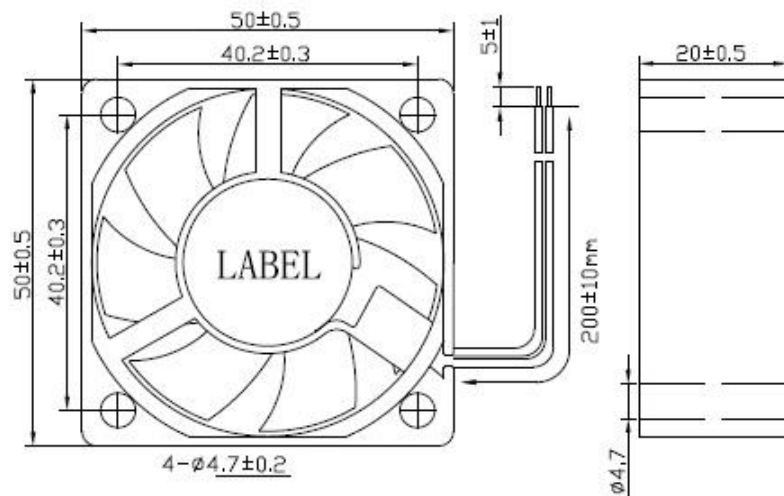

- Performance:

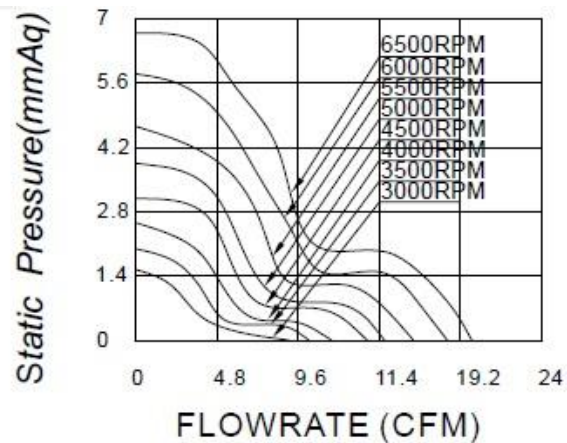

DC Axial Fan

60x60x10mm

- Housing: Plastic (Flammability:UL94V-0)
- Impeller: Plastic (Flammability:UL94V-0)
- Bearing: Ball, Sleeve
- Certification: CE, RoHS
- Additional functions are optional



Model	Voltage	Current	Power	Speed	Air Flow		Pressure		Noise
	VDC	Amp	Watt	RPM	CFM	m3/min	mmH2O	inH2O	dB(A)
AXD6010V5LR-K	5	0.072	0.36	3000	11.4	0.325	1.3	0.051	25.3
AXD6010V5L-K	5	0.096	0.48	3500	13.4	0.381	1.67	0.066	29.3
AXD6010V5M-K	5	0.12	0.6	4000	16.2	0.461	2.29	0.09	32.8
AXD6010V5H-K	5	0.144	0.72	4500	17.7	0.501	2.72	0.107	35.9
AXD6010V5HR-K	5	0.168	0.84	5000	19.4	0.55	3.34	0.131	39

DC Axial Fan

60x60x10mm

- Housing: Plastic (Flammability:UL94V-0)
- Impeller: Plastic (Flammability:UL94V-0)
- Bearing: Ball, Sleeve
- Certification: CE, RoHS
- Additional functions are optional



Model	Voltage	Current	Power	Speed	Air Flow		Pressure		Noise
	VDC	Amp	Watt	RPM	CFM	m3/min	mmH2O	inH2O	dB(A)
AXD6010V12LR-K	12	0.03	0.36	3000	11.4	0.325	1.3	0.051	25.3
AXD6010V12L-K	12	0.04	0.48	3500	13.4	0.381	1.67	0.066	29.3
AXD6010V12M-K	12	0.05	0.6	4000	16.2	0.461	2.29	0.09	32.8
AXD6010V12H-K	12	0.06	0.72	4500	17.7	0.501	2.72	0.107	35.9
AXD6010V12HR-K	12	0.07	0.84	5000	19.4	0.55	3.34	0.131	39

DC Axial Fan

60x60x10mm

- Dimension:

Unit: mm

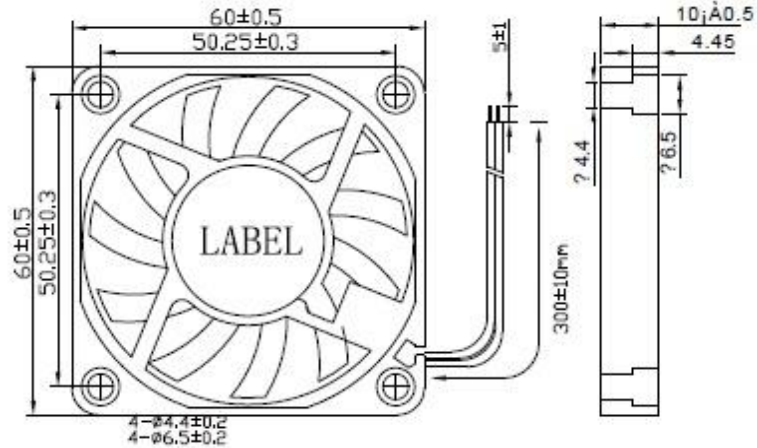

- Performance:

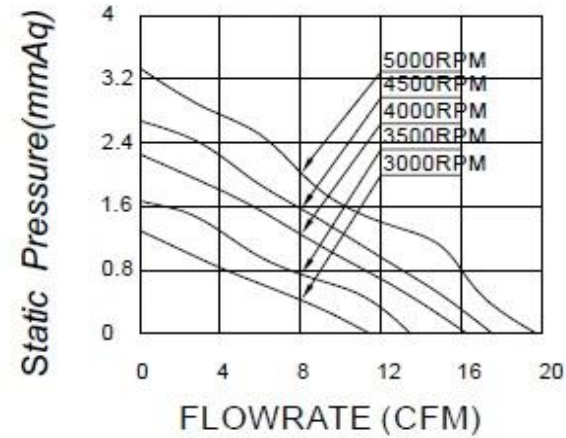

DC Axial Fan

60x60x15mm

- Housing: Plastic (Flammability:UL94V-0)
- Impeller: Plastic (Flammability:UL94V-0)
- Bearing: Ball, Sleeve
- Certification: CE, RoHS
- Additional functions are optional



Model	Voltage	Current	Power	Speed	Air Flow		Pressure		Noise
	VDC	Amp	Watt	RPM	CFM	m3/min	mmH2O	inH2O	dB(A)
AXD6015V5LR-K	5	0.14	0.72	2000	9.4	0.268	1.34	0.053	21.1
AXD6015V5L-K	5	0.19	0.96	3000	11.5	0.328	1.86	0.073	24.8
AXD6015V5M-K	5	0.24	1.2	3500	14.2	0.406	2.61	0.103	29.8
AXD6015V5H-K	5	0.29	1.44	4000	16.4	0.468	3.5	0.138	31.2

DC Axial Fan

60x60x15mm

- Housing: Plastic (Flammability:UL94V-0)
- Impeller: Plastic (Flammability:UL94V-0)
- Bearing: Ball, Sleeve
- Certification: CE, RoHS
- Additional functions are optional



Model	Voltage	Current	Power	Speed	Air Flow		Pressure		Noise
	VDC	Amp	Watt	RPM	CFM	m3/min	mmH2O	inH2O	dB(A)
AXD6015V12XL-K	12	0.06	0.72	2000	9.4	0.268	1.34	0.053	21.1
AXD6015V12LW-K	12	0.08	0.96	3000	11.5	0.328	1.86	0.073	24.8
AXD6015V12LR-K	12	0.1	1.2	3500	14.2	0.406	2.61	0.103	29.8
AXD6015V12L-K	12	0.12	1.44	4000	16.4	0.468	3.5	0.138	31.2
AXD6015V12M-K	12	0.14	1.68	4500	18.3	0.524	4.35	0.171	34.8
AXD6015V12H-K	12	0.16	1.92	5000	20.5	0.584	5.34	0.21	36.6
AXD6015V12HR-K	12	0.18	2.16	5500	22.4	0.64	6.35	0.25	39
AXD6015V12HH-K	12	0.2	2.4	6000	21.1	0.603	7.33	0.289	41

DC Axial Fan

60x60x15mm

- Housing: Plastic (Flammability:UL94V-0)
- Impeller: Plastic (Flammability:UL94V-0)
- Bearing: Ball, Sleeve
- Certification: CE, RoHS
- Additional functions are optional



Model	Voltage	Current	Power	Speed	Air Flow		Pressure		Noise
	VDC	Amp	Watt	RPM	CFM	m3/min	mmH2O	inH2O	dB(A)
AXD6015V24XL-K	24	0.03	0.72	2000	9.4	0.268	1.34	0.053	21.1
AXD6015V24LW-K	24	0.04	0.96	3000	11.5	0.328	1.86	0.073	24.8
AXD6015V24LR-K	24	0.05	1.2	3500	14.2	0.406	2.61	0.103	29.8
AXD6015V24L-K	24	0.06	1.44	4000	16.4	0.468	3.5	0.138	31.2
AXD6015V24M-K	24	0.07	1.68	4500	18.3	0.524	4.35	0.171	34.8
AXD6015V24H-K	24	0.08	1.92	5000	20.5	0.584	5.34	0.21	36.6
AXD6015V24HR-K	24	0.09	2.16	5500	22.4	0.64	6.35	0.25	39
AXD6015V24HH-K	24	0.1	2.4	6000	21.1	0.603	7.33	0.289	41

DC Axial Fan

60x60x15mm

- Dimension:

Unit: mm

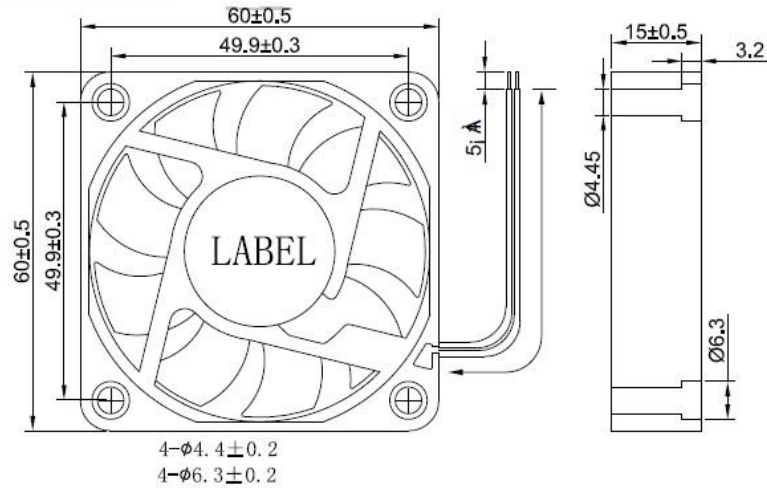

- Performance:

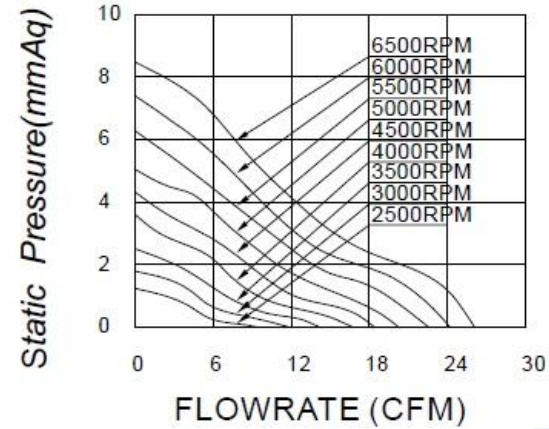

DC Axial Fan

60x60x20mm

- Housing: Plastic (Flammability:UL94V-0)
- Impeller: Plastic (Flammability:UL94V-0)
- Bearing: Ball, Sleeve
- Certification: CE, RoHS
- Additional functions are optional



Model	Voltage	Current	Power	Speed	Air Flow		Pressure		Noise
	VDC	Amp	Watt	RPM	CFM	m3/min	mmH2O	inH2O	dB(A)
AXD6020V5LR-K	5	0.06	0.72	3500	13.8	0.392	2.87	0.113	27.2
AXD6020V5L-K	5	0.08	0.96	4000	15.4	0.437	3.9	0.154	30.1
AXD6020V5M-K	5	0.1	1.2	4500	17.6	0.499	4.86	0.191	33.5
AXD6020V5H-K	5	0.12	1.44	5000	19.6	0.557	5.94	0.234	36.5
AXD6020V12LR-K	12	0.03	0.72	3500	13.8	0.392	2.87	0.113	27.2
AXD6020V12L-K	12	0.04	0.96	4000	15.4	0.437	3.9	0.154	30.1
AXD6020V12M-K	12	0.05	1.2	4500	17.6	0.499	4.86	0.191	33.5
AXD6020V12H-K	12	0.06	1.44	5000	19.6	0.557	5.94	0.234	36.5

DC Axial Fan

60x60x20mm

- Dimension:

Unit: mm

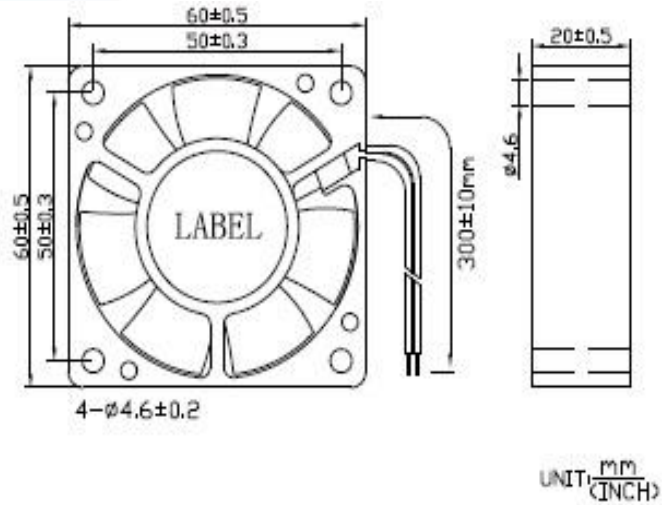

- Performance:

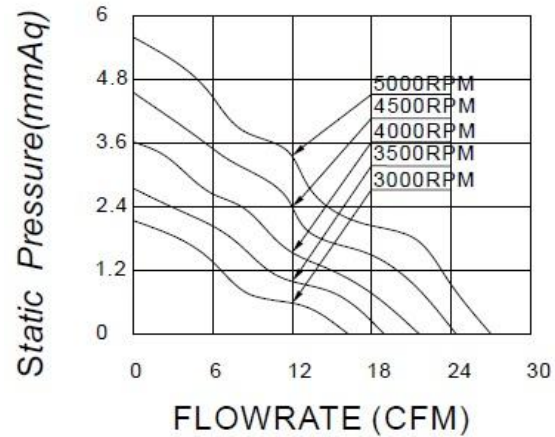

DC Axial Fan

60x60x25mm - B Type

- Housing: Plastic (Flammability:UL94V-0)
- Impeller: Plastic (Flammability:UL94V-0)
- Bearing: Ball, Sleeve
- Certification: CE, RoHS
- Additional functions are optional



Model	Voltage	Current	Power	Speed	Air Flow		Pressure		Noise
	VDC	Amp	Watt	RPM	CFM	m3/min	mmH2O	inH2O	dB(A)
AXD6025V5XL-K2	5	0.24	1.2	3000	15.6	0.443	2.92	0.115	26
AXD6025V5LW-K2	5	0.36	1.8	3500	18.4	0.523	3.87	0.152	28.7
AXD6025V5LR-K2	5	0.48	2.4	4000	21.2	0.602	5.15	0.203	31.8
AXD6025V5L-K2	5	0.6	3	4500	24.1	0.685	6.46	0.254	35.5
AXD6025V5M-K2	5	0.72	3.6	5000	26.7	0.758	7.94	0.313	38

DC Axial Fan

60x60x25mm - B Type

- Housing: Plastic (Flammability:UL94V-0)
- Impeller: Plastic (Flammability:UL94V-0)
- Bearing: Ball, Sleeve
- Certification: CE, RoHS
- Additional functions are optional



Model	Voltage	Current	Power	Speed	Air Flow		Pressure		Noise
	VDC	Amp	Watt	RPM	CFM	m3/min	mmH2O	inH2O	dB(A)
AXD6025V12XL-K2	12	0.1	1.2	3000	15.6	0.443	2.92	0.115	26
AXD6025V12LW-K2	12	0.15	1.8	3500	18.4	0.523	3.87	0.152	28.7
AXD6025V12LR-K2	12	0.2	2.4	4000	21.2	0.602	5.15	0.203	31.8
AXD6025V12L-K2	12	0.25	3	4500	24.1	0.685	6.46	0.254	35.5
AXD6025V12M-K2	12	0.3	3.6	5000	26.7	0.758	7.94	0.313	38

DC Axial Fan

60x60x25mm - B Type

- Housing: Plastic (Flammability:UL94V-0)
- Impeller: Plastic (Flammability:UL94V-0)
- Bearing: Ball, Sleeve
- Certification: CE, RoHS
- Additional functions are optional



Model	Voltage	Current	Power	Speed	Air Flow		Pressure		Noise
	VDC	Amp	Watt	RPM	CFM	m3/min	mmH2O	inH2O	dB(A)
AXD6025V12H-K2	12	0.35	4.2	5500	29.2	0.827	9.23	0.364	39.9
AXD6025V12HR-K2	12	0.38	4.56	6000	31.8	0.902	11.15	0.439	42.2
AXD6025V12HH-K2	12	0.4	4.8	6500	34.6	0.982	13.09	0.515	44.8
AXD6025V12XH-K2	12	0.45	5.4	7000	37	1.048	14.82	0.583	46
AXD6025V12HX-K2	12	0.5	6	7500	39.5	1.119	16.83	0.663	49.5

DC Axial Fan

60x60x25mm - B Type

- Housing: Plastic (Flammability:UL94V-0)
- Impeller: Plastic (Flammability:UL94V-0)
- Bearing: Ball, Sleeve
- Certification: CE, RoHS
- Additional functions are optional



Model	Voltage	Current	Power	Speed	Air Flow		Pressure		Noise
	VDC	Amp	Watt	RPM	CFM	m3/min	mmH2O	inH2O	dB(A)
AXD6025V24XL-K2	24	0.05	1.2	3000	15.6	0.443	2.92	0.115	26
AXD6025V24LW-K2	24	0.075	1.8	3500	18.4	0.523	3.87	0.152	28.7
AXD6025V24LR-K2	24	0.1	2.4	4000	21.2	0.602	5.15	0.203	31.8
AXD6025V24L-K2	24	0.125	3	4500	24.1	0.685	6.46	0.254	35.5
AXD6025V24M-K2	24	0.15	3.6	5000	26.7	0.758	7.94	0.313	38

DC Axial Fan

60x60x25mm - B Type

- Housing: Plastic (Flammability:UL94V-0)
- Impeller: Plastic (Flammability:UL94V-0)
- Bearing: Ball, Sleeve
- Certification: CE, RoHS
- Additional functions are optional



Model	Voltage	Current	Power	Speed	Air Flow		Pressure		Noise
	VDC	Amp	Watt	RPM	CFM	m3/min	mmH2O	inH2O	dB(A)
AXD6025V24H-K2	24	0.175	4.2	5500	29.2	0.827	9.23	0.364	39.9
AXD6025V24HR-K 2	24	0.19	4.56	6000	31.8	0.902	11.15	0.439	42.2
AXD6025V24HH-K 2	24	0.2	4.8	6500	34.6	0.982	13.09	0.515	44.8
AXD6025V24XH-K2	24	0.225	5.4	7000	37	1.048	14.82	0.583	46
AXD6025V24HX-K2	24	0.25	6	7500	39.5	1.119	16.83	0.663	49.5

DC Axial Fan

60x60x25mm - B Type

- Housing: Plastic (Flammability:UL94V-0)
- Impeller: Plastic (Flammability:UL94V-0)
- Bearing: Ball, Sleeve
- Certification: CE, RoHS
- Additional functions are optional



Model	Voltage	Current	Power	Speed	Air Flow		Pressure		Noise
	VDC	Amp	Watt	RPM	CFM	m3/min	mmH2O	inH2O	dB(A)
AXD6025V48LR-K2	48	0.05	2.4	4000	21.2	0.602	5.15	0.203	31.8
AXD6025V48L-K2	48	0.063	3	4500	24.1	0.685	6.46	0.254	35.5
AXD6025V48M-K2	48	0.075	3.6	5000	26.7	0.758	7.94	0.313	38
AXD6025V48H-K2	48	0.088	4.2	5500	29.2	0.827	9.23	0.364	39.9
AXD6025V48HR-K 2	48	0.095	4.56	6000	31.8	0.902	11.15	0.439	42.2
AXD6025V48HH-K 2	48	0.1	4.8	6500	34.6	0.982	13.09	0.515	44.8
AXD6025V48XH-K2	48	0.113	5.4	7000	37	1.048	14.82	0.583	46
AXD6025V48HX-K2	48	0.125	6	7500	39.5	1.119	16.83	0.663	49.5

DC Axial Fan

60x60x25mm - B Type

- Dimension:

Unit: mm

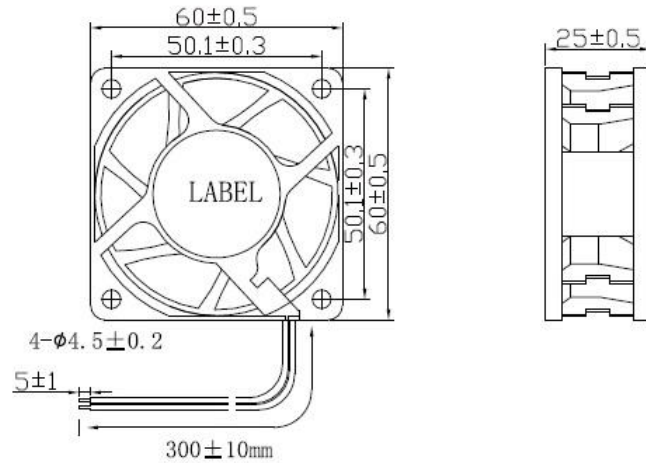

- Performance:

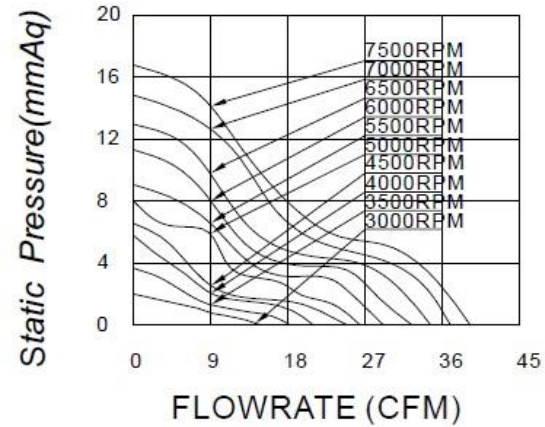

DC Axial Fan

60x60x32mm

- Housing: Plastic (Flammability:UL94V-0)
- Impeller: Plastic (Flammability:UL94V-0)
- Bearing: Ball, Sleeve
- Certification: CE, RoHS
- Additional functions are optional



Model	Voltage	Current	Power	Speed	Air Flow		Pressure		Noise
	VDC	Amp	Watt	RPM	CFM	m3/min	mmH2O	inH2O	dB(A)
AXD6032V12LR-K	12	0.51	6.16	7000	40.2	1.138	15.7	2.107	53.5
AXD6032V12L-K	12	0.68	8.1	8000	45.9	1.299	20.1	2.131	54.1
AXD6032V12M-K	12	0.94	11.28	9000	49.5	1.401	23.4	2.202	55.9
AXD6032V12H-K	12	1.26	15.12	10000	55.2	1.563	29.3	2.466	62.6
AXD6032V12HR-K	12	1.6	19.2	11000	60.3	1.707	35	2.679	68

DC Axial Fan

60x60x32mm

- Housing: Plastic (Flammability:UL94V-0)
- Impeller: Plastic (Flammability:UL94V-0)
- Bearing: Ball, Sleeve
- Certification: CE, RoHS
- Additional functions are optional



Model	Voltage	Current	Power	Speed	Air Flow		Pressure		Noise
	VDC	Amp	Watt	RPM	CFM	m3/min	mmH2O	inH2O	dB(A)
AXD6032V24LR-K	24	0.26	6.16	7000	40.2	1.138	15.7	2.107	53.5
AXD6032V24L-K	24	0.34	8.1	8000	45.9	1.299	20.1	2.131	54.1
AXD6032V24M-K	24	0.47	11.28	9000	49.5	1.401	23.4	2.202	55.9
AXD6032V24H-K	24	0.63	15.12	10000	55.2	1.563	29.3	2.466	62.6
AXD6032V24HR-K	24	0.8	19.2	11000	60.3	1.707	35	2.679	68

DC Axial Fan

60x60x32mm

- Housing: Plastic (Flammability:UL94V-0)
- Impeller: Plastic (Flammability:UL94V-0)
- Bearing: Ball, Sleeve
- Certification: CE, RoHS
- Additional functions are optional



Model	Voltage	Current	Power	Speed	Air Flow		Pressure		Noise
	VDC	Amp	Watt	RPM	CFM	m3/min	mmH2O	inH2O	dB(A)
AXD6032V48LR-K	48	0.13	6.16	7000	40.2	1.138	15.7	2.107	53.5
AXD6032V48L-K	48	0.17	8.1	8000	45.9	1.299	20.1	2.131	54.1
AXD6032V48M-K	48	0.24	11.28	9000	49.5	1.401	23.4	2.202	55.9
AXD6032V48H-K	48	0.32	15.12	10000	55.2	1.563	29.3	2.466	62.6
AXD6032V48HR-K	48	0.4	19.2	11000	60.3	1.707	35	2.679	68

DC Axial Fan

60x60x32mm

- Dimension:

Unit: mm

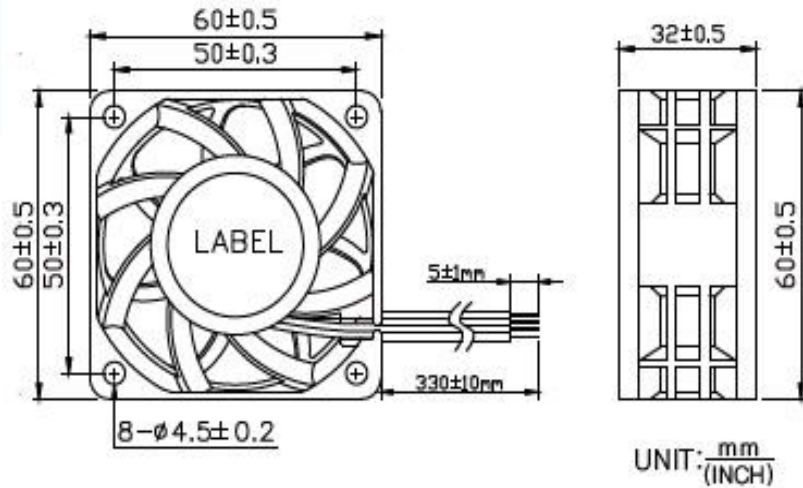

- Performance:

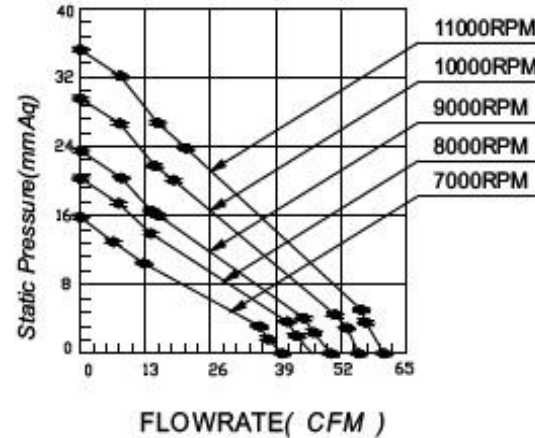

DC Axial Fan

60x60x38mm - B Type

- Housing: Plastic (Flammability:UL94V-0)
- Impeller: Plastic (Flammability:UL94V-0)
- Bearing: Ball
- Certification: CE, RoHS
- Additional functions are optional



Model	Voltage	Current	Power	Speed	Air Flow		Pressure		Noise
	VDC	Amp	Watt	RPM	CFM	m3/min	mmH2O	inH2O	dB(A)
AXD6038V12H-K2	12	2.7	32.4	21700	66.4	1.88	177.8	7	68
AXD6038V24H-K2	24	1.35	32.4	21700	66.4	1.88	177.8	7	68
AXD6038V48H-K2	48	0.68	32.4	21700	66.4	1.88	177.8	7	68

DC Axial Fan

60x60x38mm - B Type

- Dimension:

Unit: mm

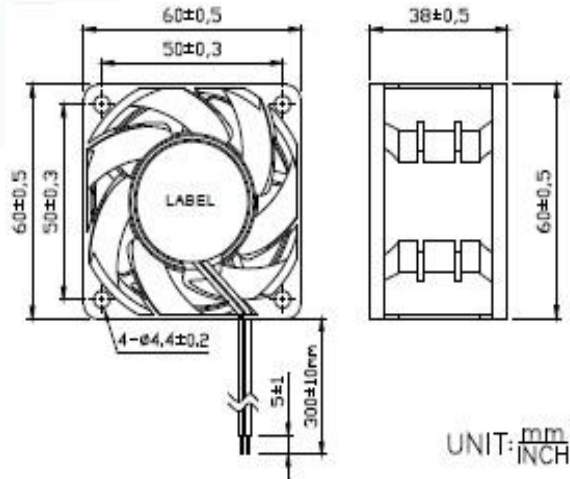

- Performance:

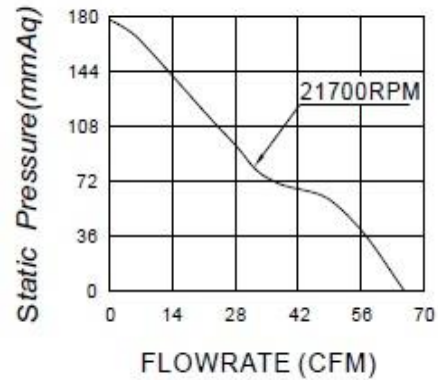

DC Axial Fan

60x60x38mm - C Type

- Housing: Plastic (Flammability:UL94V-0)
- Impeller: Plastic (Flammability:UL94V-0)
- Bearing: Ball
- Certification: CE, RoHS
- Additional functions are optional



Model	Voltage	Current	Power	Speed	Air Flow		Pressure		Noise
	VDC	Amp	Watt	RPM	CFM	m3/min	mmH2O	inH2O	dB(A)
AXD6038V12XL-K3	12	0.6	7.2	10000	39.5	1.118	29.29	1.153	55.9
AXD6038V12LW-K3	12	0.7	8.4	11000	46.2	1.307	31.1	1.224	57.6
AXD6038V12LR-K3	12	0.9	10.8	12000	52.0	1.473	48.51	1.91	61.8
AXD6038V12L-K3	12	1	12	13000	55.9	1.582	55.9	2.201	63.7
AXD6038V12M-K3	12	1.2	14.4	14000	60.3	1.705	64.98	2.558	64.7
AXD6038V12H-K3	12	1.3	15.6	15000	64.3	1.819	77.37	3.046	68.8
AXD6038V12HR-K3	12	1.4	16.8	16000	65.3	1.849	83.69	3.295	70.8

DC Axial Fan

60x60x38mm - C Type

- Housing: Plastic (Flammability:UL94V-0)
- Impeller: Plastic (Flammability:UL94V-0)
- Bearing: Ball
- Certification: CE, RoHS
- Additional functions are optional



Model	Voltage	Current	Power	Speed	Air Flow		Pressure		Noise
	VDC	Amp	Watt	RPM	CFM	m3/min	mmH2O	inH2O	dB(A)
AXD6038V24XL-K3	24	0.3	7.2	10000	39.5	1.118	29.29	1.153	55.9
AXD6038V24LW-K3	24	0.35	8.4	11000	46.2	1.307	31.1	1.224	57.6
AXD6038V24LR-K3	24	0.45	10.8	12000	52.0	1.473	48.51	1.91	61.8
AXD6038V24L-K3	24	0.5	12	13000	55.9	1.582	55.9	2.201	63.7
AXD6038V24M-K3	24	0.6	14.4	14000	60.3	1.705	64.98	2.558	64.7
AXD6038V24H-K3	24	0.65	15.6	15000	64.3	1.819	77.37	3.046	68.8
AXD6038V24HR-K3	24	0.7	16.8	16000	65.3	1.849	83.69	3.295	70.8

DC Axial Fan

60x60x38mm - C Type

- Housing: Plastic (Flammability:UL94V-0)
- Impeller: Plastic (Flammability:UL94V-0)
- Bearing: Ball
- Certification: CE, RoHS
- Additional functions are optional



Model	Voltage	Current	Power	Speed	Air Flow		Pressure		Noise
	VDC	Amp	Watt	RPM	CFM	m3/min	mmH2O	inH2O	dB(A)
AXD6038V48XL-K3	48	0.15	7.2	10000	39.5	1.118	29.29	1.153	55.9
AXD6038V48LW-K3	48	0.175	8.4	11000	46.2	1.307	31.1	1.224	57.6
AXD6038V48LR-K3	48	0.225	10.8	12000	52.0	1.473	48.51	1.91	61.8
AXD6038V48L-K3	48	0.25	12	13000	55.9	1.582	55.9	2.201	63.7
AXD6038V48M-K3	48	0.3	14.4	14000	60.3	1.705	64.98	2.558	64.7
AXD6038V48H-K3	48	0.325	15.6	15000	64.3	1.819	77.37	3.046	68.8
AXD6038V48HR-K3	48	0.35	16.8	16000	65.3	1.849	83.69	3.295	70.8

DC Axial Fan

60x60x38mm - C Type

- Dimension:

Unit: mm

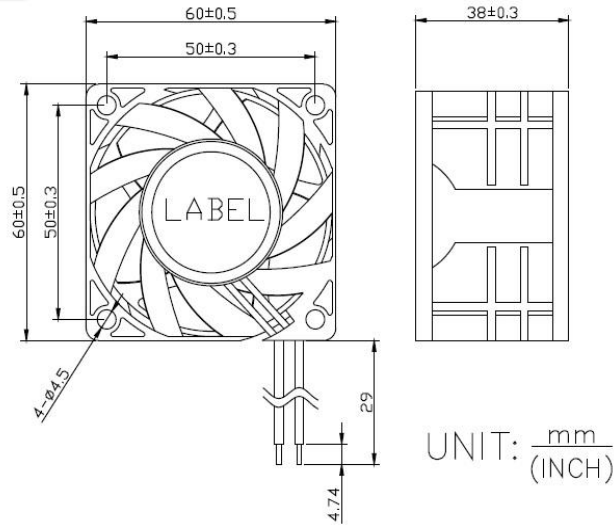

- Performance:

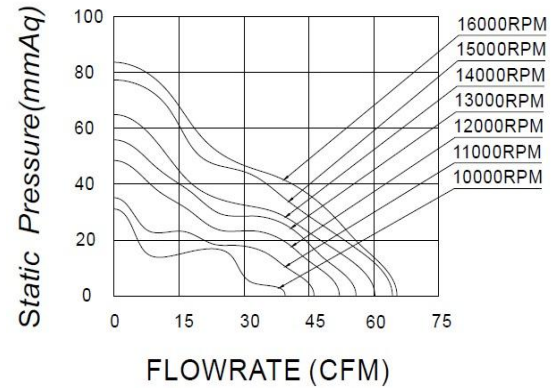

DC Axial Fan

70x70x15mm

- Housing: Plastic (Flammability:UL94V-0)
- Impeller: Plastic (Flammability:UL94V-0)
- Bearing: Ball
- Certification: CE, RoHS
- Additional functions are optional



Model	Voltage	Current	Power	Speed	Air Flow		Pressure		Noise
	VDC	Amp	Watt	RPM	CFM	m3/min	mmH2O	inH2O	dB(A)
AXD7015V5LW-K	5	0.1	0.48	2000	13.9	0.395	0.89	0.035	22.9
AXD7015V12LR-K	12	0.04	0.48	2500	14.8	0.421	1.36	0.054	22.9
AXD7015V12L-K	12	0.06	0.72	3000	19.7	0.558	2.1	0.083	27.2
AXD7015V12M-K	12	0.08	0.96	3500	23.0	0.652	2.92	0.115	33.3
AXD7015V12H-K	12	0.12	1.44	4000	26.0	0.737	3.55	0.14	36.2
AXD7015V12HR-K	12	0.18	2.16	4500	29.8	0.844	4.62	0.182	38.9

DC Axial Fan

70x70x15mm

- Housing: Plastic (Flammability:UL94V-0)
- Impeller: Plastic (Flammability:UL94V-0)
- Bearing: Ball
- Certification: CE, RoHS
- Additional functions are optional



Model	Voltage	Current	Power	Speed	Air Flow		Pressure		Noise
	VDC	Amp	Watt	RPM	CFM	m3/min	mmH2O	inH2O	dB(A)
AXD7015V24LR-K	24	0.02	0.48	2500	14.8	0.421	1.36	0.054	22.9
AXD7015V24L-K	24	0.03	0.72	3000	19.7	0.558	2.1	0.083	27.2
AXD7015V24M-K	24	0.04	0.96	3500	23.0	0.652	2.92	0.115	33.3
AXD7015V24H-K	24	0.06	1.44	4000	26.0	0.737	3.55	0.14	36.2
AXD7015V24HR-K	24	0.09	2.16	4500	29.8	0.844	4.62	0.182	38.9

DC Axial Fan

70x70x15mm

- Dimension:

Unit: mm

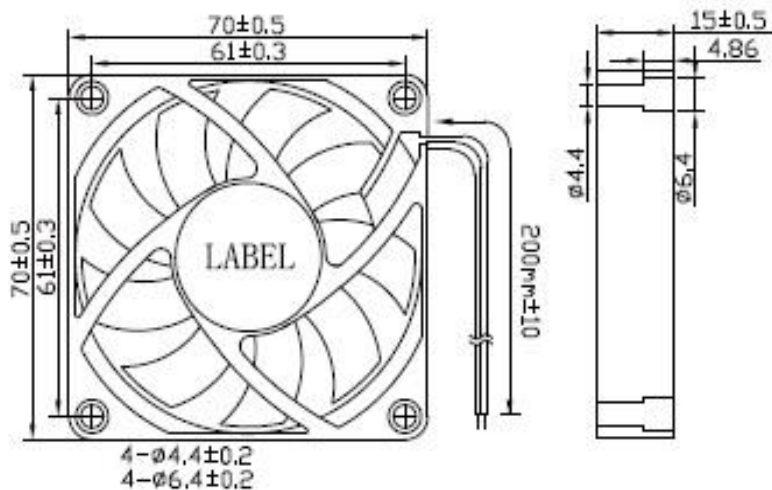

- Performance:

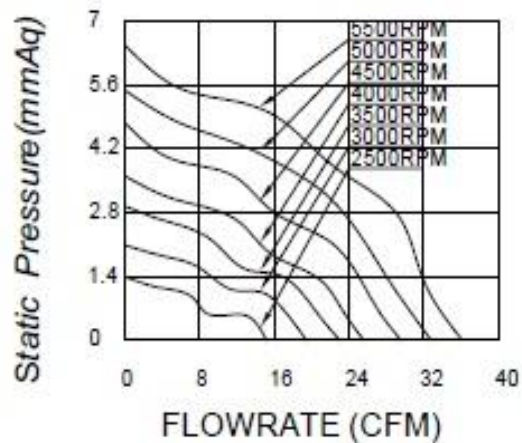

DC Axial Fan

70x70x20mm

- Housing: Plastic (Flammability:UL94V-0)
- Impeller: Plastic (Flammability:UL94V-0)
- Bearing: Ball
- Certification: CE, RoHS
- Additional functions are optional



Model	Voltage	Current	Power	Speed	Air Flow		Pressure		Noise
	VDC	Amp	Watt	RPM	CFM	m3/min	mmH2O	inH2O	dB(A)
AXD7020V12LW-K	12	0.1	1.2	2000	16.6	0.472	1.07	0.042	24.2
AXD7020V12LR-K	12	0.18	2.16	2500	21.8	0.62	1.78	0.07	25.8
AXD7020V12L-K	12	0.27	3.24	3000	26.0	0.738	2.44	0.096	30.4
AXD7020V12M-K	12	0.35	4.2	3500	31.1	0.882	3.33	0.131	34.5
AXD7020V12H-K	12	0.42	5.04	4000	35.3	1.001	4.41	0.174	38.3
AXD7020V12HR-K	12	0.48	5.76	4500	40.4	1.144	5.69	0.224	42.2

DC Axial Fan

70x70x20mm

- Housing: Plastic (Flammability:UL94V-0)
- Impeller: Plastic (Flammability:UL94V-0)
- Bearing: Ball
- Certification: CE, RoHS
- Additional functions are optional



Model	Voltage	Current	Power	Speed	Air Flow		Pressure		Noise
	VDC	Amp	Watt	RPM	CFM	m3/min	mmH2O	inH2O	dB(A)
AXD7020V24LW-K	24	0.05	1.2	2000	16.6	0.472	1.07	0.042	24.2
AXD7020V24LR-K	24	0.09	2.16	2500	21.8	0.62	1.78	0.07	25.8
AXD7020V24L-K	24	0.135	3.24	3000	26.0	0.738	2.44	0.096	30.4
AXD7020V24M-K	24	0.175	4.2	3500	31.1	0.882	3.33	0.131	34.5
AXD7020V24H-K	24	0.21	5.04	4000	35.3	1.001	4.41	0.174	38.3
AXD7020V24HR-K	24	0.24	5.76	4500	40.4	1.144	5.69	0.224	42.2

DC Axial Fan

70x70x20mm

- Dimension:

Unit: mm

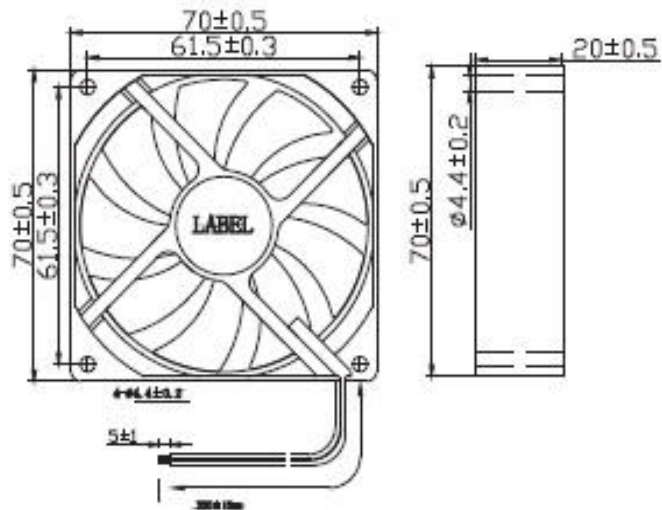

- Performance:

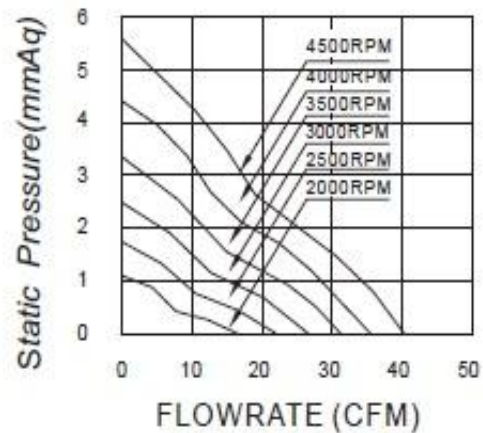

DC Axial Fan

70x70x25mm

- Housing: Plastic (Flammability:UL94V-0)
- Impeller: Plastic (Flammability:UL94V-0)
- Bearing: Ball
- Certification: CE, RoHS
- Additional functions are optional



Model	Voltage	Current	Power	Speed	Air Flow		Pressure		Noise
	VDC	Amp	Watt	RPM	CFM	m3/min	mmH2O	inH2O	dB(A)
AXD7025V12LR-K	12	0.14	1.68	3000	26.8	0.76	2.93	0.115	32.5
AXD7025V12L-K	12	0.176	2.16	3500	31.2	0.886	3.84	0.151	36
AXD7025V12M-K	12	0.22	2.64	4000	36.0	1.022	5.09	0.2	40.9
AXD7025V12H-K	12	0.26	3.12	4500	40.5	1.147	6.29	0.248	43
AXD7025V12HR-K	12	0.32	3.84	5000	44.9	1.274	7.8	0.307	47.3

DC Axial Fan

70x70x25mm

- Housing: Plastic (Flammability:UL94V-0)
- Impeller: Plastic (Flammability:UL94V-0)
- Bearing: Ball
- Certification: CE, RoHS
- Additional functions are optional



Model	Voltage	Current	Power	Speed	Air Flow		Pressure		Noise
	VDC	Amp	Watt	RPM	CFM	m3/min	mmH2O	inH2O	dB(A)
AXD7025V24LR-K	24	0.07	1.68	3000	26.8	0.76	2.93	0.115	32.5
AXD7025V24L-K	24	0.09	2.16	3500	31.2	0.886	3.84	0.151	36
AXD7025V24M-K	24	0.11	2.64	4000	36.0	1.022	5.09	0.2	40.9
AXD7025V24H-K	24	0.13	3.12	4500	40.5	1.147	6.29	0.248	43
AXD7025V24HR-K	24	0.16	3.84	5000	44.9	1.274	7.8	0.307	47.3

DC Axial Fan

70x70x25mm

- Housing: Plastic (Flammability:UL94V-0)
- Impeller: Plastic (Flammability:UL94V-0)
- Bearing: Ball
- Certification: CE, RoHS
- Additional functions are optional



Model	Voltage	Current	Power	Speed	Air Flow		Pressure		Noise
	VDC	Amp	Watt	RPM	CFM	m3/min	mmH2O	inH2O	dB(A)
AXD7025V48L-K	48	0.045	2.16	3500	31.2	0.886	3.84	0.151	36
AXD7025V48M-K	48	0.055	2.64	4000	36.0	1.022	5.09	0.2	40.9
AXD7025V48H-K	48	0.065	3.12	4500	40.5	1.147	6.29	0.248	43
AXD7025V48HR-K	48	0.08	3.84	5000	44.9	1.274	7.8	0.307	47.3

DC Axial Fan

70x70x25mm

- Dimension:

Unit: mm

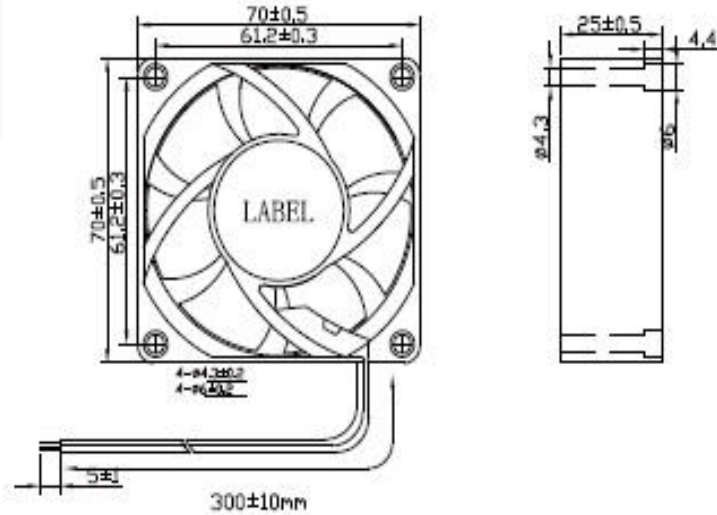

- Performance:

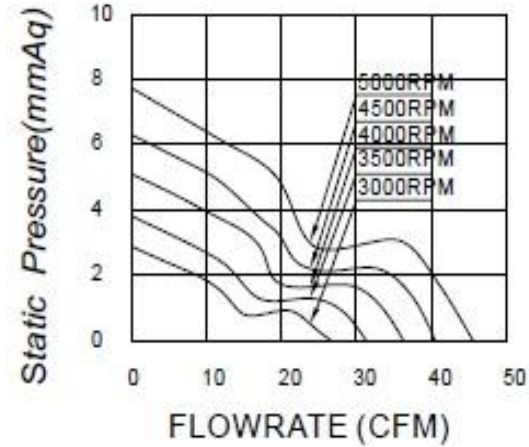

DC Axial Fan

80x80x10mm

- Housing: Plastic (Flammability:UL94V-0)
- Impeller: Plastic (Flammability:UL94V-0)
- Bearing: Ball
- Certification: CE, RoHS
- Additional functions are optional



Model	Voltage	Current	Power	Speed	Air Flow		Pressure		Noise
	VDC	Amp	Watt	RPM	CFM	m ³ /min	mmH ₂ O	inH ₂ O	dB(A)
AXD8010V5LR-K	5	0.144	0.72	2000	13.9	0.395	0.89	0.035	22.9
AXD8010V12LR-K	12	0.06	0.72	2000	13.9	0.395	0.89	0.035	22.9
AXD8010V12L-K	12	0.1	1.2	2500	17.8	0.506	1.2	0.047	26.5
AXD8010V12M-K	12	0.16	1.92	3000	21.8	0.619	1.71	0.067	30.7
AXD8010V12H-K	12	0.22	2.64	3500	25.6	0.725	2.44	0.096	34.9
AXD8010V24LR-K	24	0.03	0.72	2000	13.9	0.395	0.89	0.035	22.9
AXD8010V24L-K	24	0.05	1.2	2500	17.8	0.506	1.2	0.047	26.5
AXD8010V24M-K	24	0.08	1.92	3000	21.8	0.619	1.71	0.067	30.7
AXD8010V24H-K	24	0.11	2.64	3500	25.6	0.725	2.44	0.096	34.9

DC Axial Fan

80x80x10mm

- Dimension:

Unit: mm

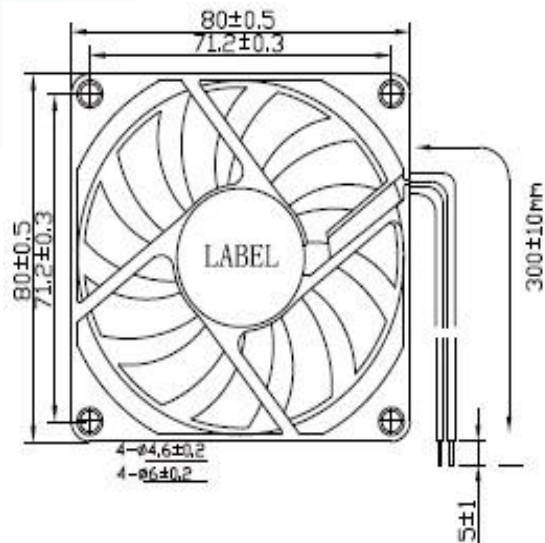

- Performance:

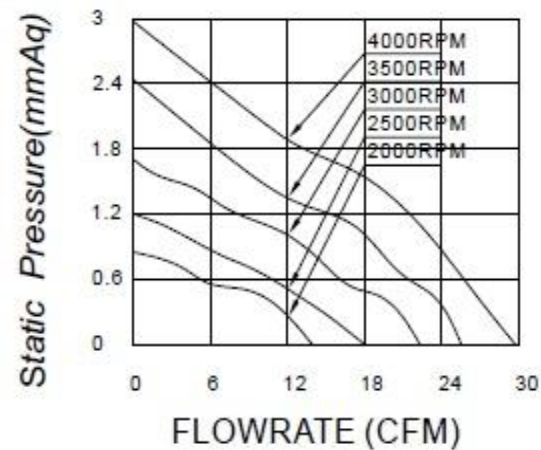

DC Axial Fan

80x80x15mm

- Housing: Plastic (Flammability:UL94V-0)
- Impeller: Plastic (Flammability:UL94V-0)
- Bearing: Ball
- Certification: CE, RoHS
- Additional functions are optional



Model	Voltage	Current	Power	Speed	Air Flow		Pressure		Noise
	VDC	Amp	Watt	RPM	CFM	m3/min	mmH2O	inH2O	dB(A)
AXD8015V5LR-K	5	0.24	1.2	2000	22.8	0.645	1.2	0.047	30.4
AXD8015V12LR-K	12	0.1	1.2	2000	22.8	0.645	1.2	0.047	30.4
AXD8015V12L-K	12	0.13	1.56	2500	25.0	0.708	1.65	0.065	33.5
AXD8015V12M-K	12	0.21	2.52	3000	31.9	0.903	2.44	0.096	36.2
AXD8015V12H-K	12	0.3	3.6	3500	36.6	1.036	3.38	0.133	40.3
AXD8015V24LR-K	24	0.06	1.44	2000	22.8	0.645	1.2	0.047	30.4
AXD8015V24L-K	24	0.08	1.92	2500	25.0	0.708	1.65	0.065	33.5
AXD8015V24M-K	24	0.1	2.4	3000	31.9	0.903	2.44	0.096	36.2
AXD8015V24H-K	24	0.18	4.32	3500	36.6	1.036	3.38	0.133	40.3

DC Axial Fan

80x80x15mm

- Dimension:

Unit: mm

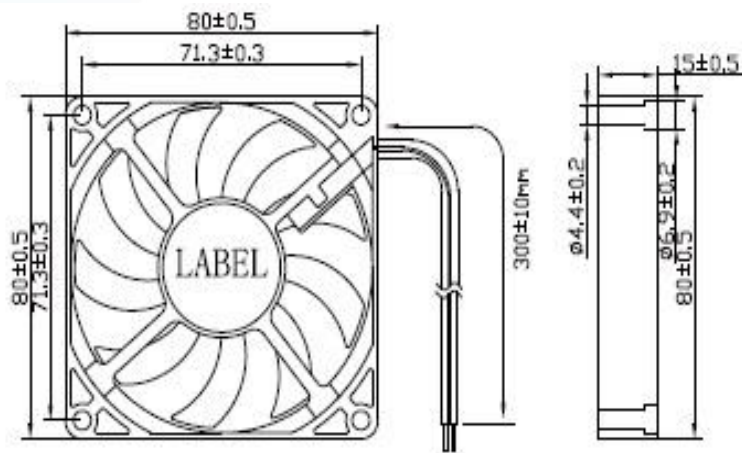

4- $\phi 4.4 \pm 0.2$

4- $\phi 6.9 \pm 0.2$

- Performance:

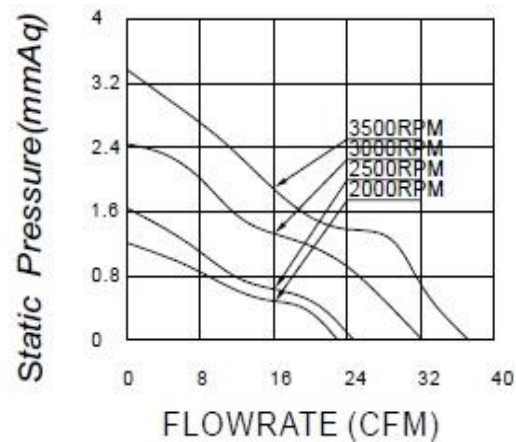

DC Axial Fan

80x80x20mm

- Housing: Plastic (Flammability:UL94V-0)
- Impeller: Plastic (Flammability:UL94V-0)
- Bearing: Ball
- Certification: CE, RoHS
- Additional functions are optional



Model	Voltage	Current	Power	Speed	Air Flow		Pressure		Noise
	VDC	Amp	Watt	RPM	CFM	m3/min	mmH2O	inH2O	dB(A)
AXD8020V12LR-K	12	0.16	1.92	3000	30.9	0.874	2.82	0.111	35.7
AXD8020V12L-K	12	0.22	2.64	3500	35.7	1.01	3.6	0.142	38.5
AXD8020V12M-K	12	0.26	3.12	4000	40.1	1.135	4.41	0.174	41.6
AXD8020V12H-K	12	0.34	4.08	4500	45.1	1.276	5.51	0.217	45.3

DC Axial Fan

80x80x20mm

- Housing: Plastic (Flammability:UL94V-0)
- Impeller: Plastic (Flammability:UL94V-0)
- Bearing: Ball
- Certification: CE, RoHS
- Additional functions are optional



Model	Voltage	Current	Power	Speed	Air Flow		Pressure		Noise
	VDC	Amp	Watt	RPM	CFM	m3/min	mmH2O	inH2O	dB(A)
AXD8020V24LR-K	24	0.08	1.92	3000	30.9	0.874	2.82	0.111	35.7
AXD8020V24L-K	24	0.11	2.64	3500	35.7	1.01	3.6	0.142	38.5
AXD8020V24M-K	24	0.13	3.12	4000	40.1	1.135	4.41	0.174	41.6
AXD8020V24H-K	24	0.17	4.08	4500	45.1	1.276	5.51	0.217	45.3

DC Axial Fan

80x80x20mm

- Housing: Plastic (Flammability:UL94V-0)
- Impeller: Plastic (Flammability:UL94V-0)
- Bearing: Ball
- Certification: CE, RoHS
- Additional functions are optional



Model	Voltage	Current	Power	Speed	Air Flow		Pressure		Noise
	VDC	Amp	Watt	RPM	CFM	m3/min	mmH2O	inH2O	dB(A)
AXD8020V48LR-K	48	0.04	1.92	3000	30.9	0.874	2.82	0.111	35.7
AXD8020V48L-K	48	0.055	2.64	3500	35.7	1.01	3.6	0.142	38.5
AXD8020V48M-K	48	0.065	3.12	4000	40.1	1.135	4.41	0.174	41.6
AXD8020V48H-K	48	0.08	4.08	4500	45.1	1.276	5.51	0.217	45.3

DC Axial Fan

80x80x20mm

- Dimension:

Unit: mm

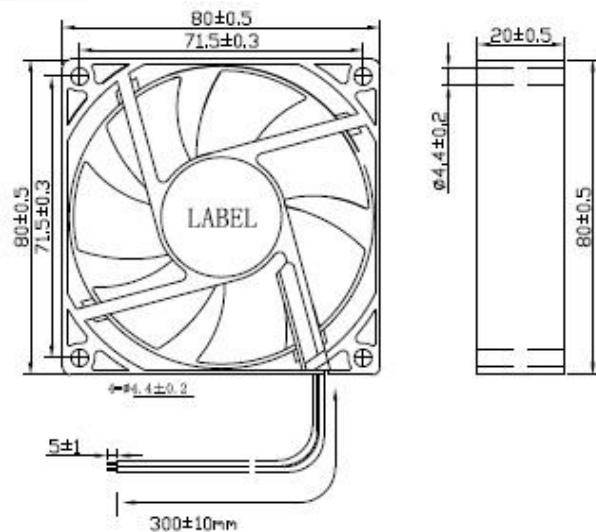

- Performance:

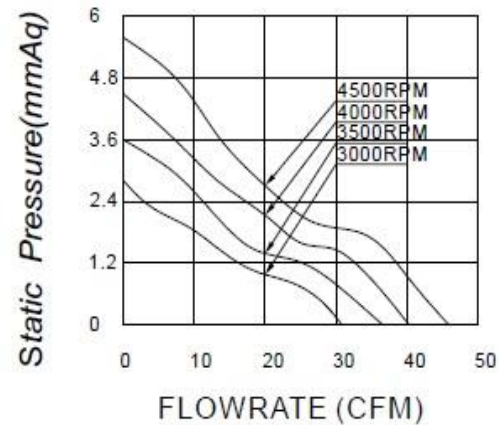

DC Axial Fan

80x80x25mm

- Housing: Plastic (Flammability:UL94V-0)
- Impeller: Plastic (Flammability:UL94V-0)
- Bearing: Ball
- Certification: CE, RoHS
- Additional functions are optional



Model	Voltage	Current	Power	Speed	Air Flow		Pressure		Noise
	VDC	Amp	Watt	RPM	CFM	m3/min	mmH2O	inH2O	dB(A)
AXD8025V12LW-K	12	0.08	0.96	2000	24.4	0.69	2	0.08	25.8
AXD8025V12LR-K	12	0.12	1.44	2500	31.4	0.89	2.8	0.11	29.1
AXD8025V12L-K	12	0.15	1.8	3000	37.9	1.07	4	0.16	34.2
AXD8025V12M-K	12	0.25	3	3500	44.3	1.25	5.3	0.21	36.9
AXD8025V12H-K	12	0.3	3.6	4000	50.8	1.44	7	0.28	41.8
AXD8025V12HR-K	12	0.5	6	4500	57.6	1.63	8.5	0.33	45.4
AXD8025V12HH-K	12	0.63	7.56	5000	60.5	1.71	8.9	0.35	46.3

DC Axial Fan

80x80x25mm

- Housing: Plastic (Flammability:UL94V-0)
- Impeller: Plastic (Flammability:UL94V-0)
- Bearing: Ball
- Certification: CE, RoHS
- Additional functions are optional



Model	Voltage	Current	Power	Speed	Air Flow		Pressure		Noise
	VDC	Amp	Watt	RPM	CFM	m3/min	mmH2O	inH2O	dB(A)
AXD8025V24L-K	24	0.08	1.92	3000	37.9	1.07	4	0.16	34.2
AXD8025V24M-K	24	0.16	3.84	4000	50.8	1.44	7	0.28	41.8
AXD8025V24H-K	24	0.32	7.68	5000	60.5	1.71	8.9	0.35	46.3
AXD8025V48L-K	48	0.04	1.92	3000	37.9	1.07	4	0.16	34.2
AXD8025V48M-K	48	0.08	3.84	4000	50.8	1.44	7	0.28	41.8
AXD8025V48H-K	48	0.17	8.16	5000	60.5	1.71	8.9	0.35	46.3

DC Axial Fan

80x80x25mm

- Dimension:

Unit: mm

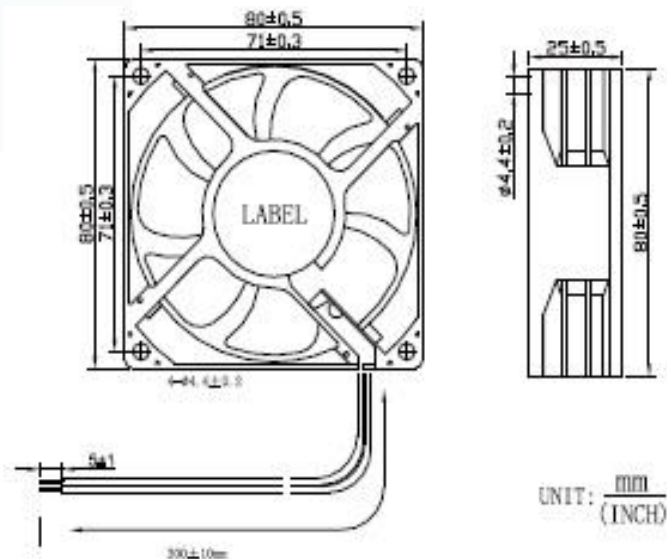

- Performance:

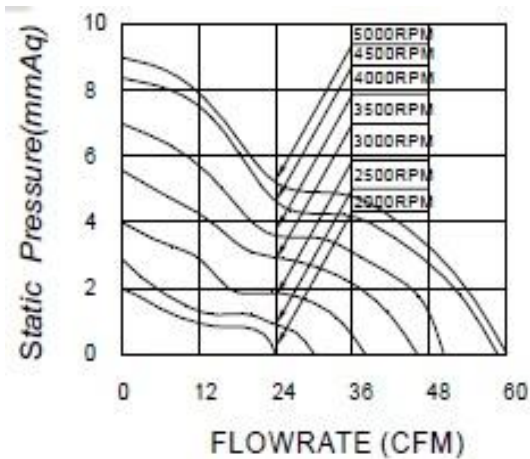

DC Axial Fan

80x80x25mm - E Type

- Housing: Plastic (Flammability:UL94V-0)
- Impeller: Plastic (Flammability:UL94V-0)
- Bearing: Ball
- Certification: CE, RoHS
- Additional functions are optional



Model	Voltage	Current	Power	Speed	Air Flow		Pressure		Noise
	VDC	Amp	Watt	RPM	CFM	m3/min	mmH2O	inH2O	dB(A)
AXD8025V12LW-K5	12	0.12	1.44	2550	34.8	0.984	3.02	0.119	32.9
AXD8025V12LR-K5	12	0.15	1.8	3000	41.7	1.18	4.25	0.167	35.7
AXD8025V12L-K5	12	0.25	3	3500	48.7	1.378	5.73	0.226	39.4
AXD8025V12M-K5	12	0.3	3.6	4000	54.5	1.543	7.35	0.289	44.6
AXD8025V12H-K5	12	0.36	4.32	4500	62.3	1.765	9.2	0.362	47.3
AXD8025V12HR-K5	12	0.56	6.72	5000	67.5	1.911	11.6	0.457	49.8
AXD8025V12HH-K5	12	0.66	7.92	5500	72.8	2.061	14	0.551	52

DC Axial Fan

80x80x25mm - E Type

- Housing: Plastic (Flammability:UL94V-0)
- Impeller: Plastic (Flammability:UL94V-0)
- Bearing: Ball
- Certification: CE, RoHS
- Additional functions are optional



Model	Voltage	Current	Power	Speed	Air Flow		Pressure		Noise
	VDC	Amp	Watt	RPM	CFM	m3/min	mmH2O	inH2O	dB(A)
AXD8025V24LR-K5	24	0.1	2.4	3000	41.7	1.18	4.25	0.167	35.7
AXD8025V24L-K5	24	0.16	3.84	4000	54.5	1.543	7.35	0.289	44.6
AXD8025V24M-K5	24	0.26	6.24	5000	67.5	1.911	11.6	0.457	49.8
AXD8025V24H-K5	24	0.35	8.4	5500	72.8	2.061	14	0.551	52
AXD8025V48LR-K5	48	0.06	2.88	3000	41.7	1.18	4.25	0.167	35.7
AXD8025V48L-K5	48	0.12	5.76	4000	54.5	1.543	7.35	0.289	44.6
AXD8025V48M-K5	48	0.17	8.16	5000	67.5	1.911	11.6	0.457	49.8
AXD8025V48H-K5	48	0.22	10.56	5500	72.8	2.061	14	0.551	52

DC Axial Fan

80x80x25mm - E Type

- Dimension:

Unit: mm

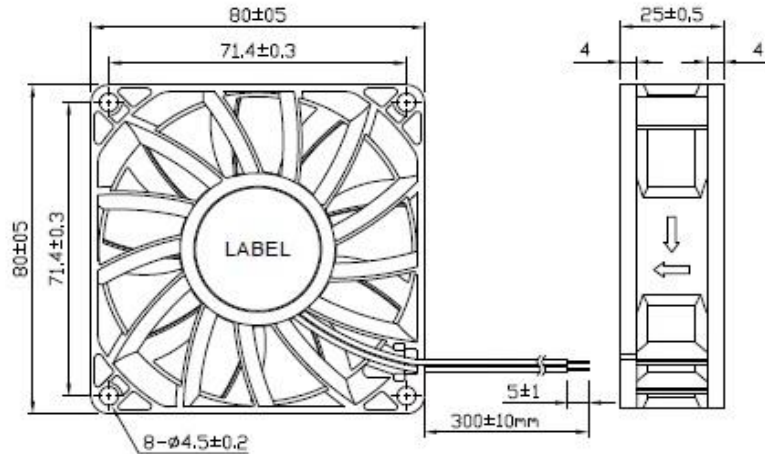

UNIT: $\frac{\text{mm}}{(\text{INCH})}$

- Performance:

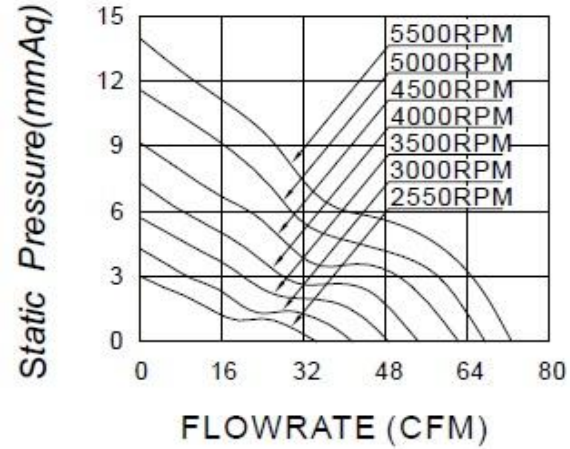

DC Axial Fan

80x80x32mm

- Housing: Plastic (Flammability:UL94V-0)
- Impeller: Plastic (Flammability:UL94V-0)
- Bearing: Ball
- Certification: CE, RoHS
- Additional functions are optional



Model	Voltage	Current	Power	Speed	Air Flow		Pressure		Noise
	VDC	Amp	Watt	RPM	CFM	m3/min	mmH2O	inH2O	dB(A)
AXD8032V12LW-K	12	0.4	4.8	4000	49.9	1.413	8.51	0.335	46.8
AXD8032V12LR-K	12	0.68	8.16	5000	61.3	1.736	11.63	0.458	50.3
AXD8032V12L-K	12	0.96	11.5	6000	75.5	2.138	16.78	0.661	52
AXD8032V12M-K	12	1.24	14.9	7000	88.9	2.518	22.39	0.881	54.2
AXD8032V12H-K	12	1.51	18.2	8000	100.8	2.856	29.53	1.163	61.2
AXD8032V12HR-K	12	1.84	22.1	8500	107.1	3.034	32.9	1.295	63.5

DC Axial Fan

80x80x32mm

- Housing: Plastic (Flammability:UL94V-0)
- Impeller: Plastic (Flammability:UL94V-0)
- Bearing: Ball
- Certification: CE, RoHS
- Additional functions are optional



Model	Voltage	Current	Power	Speed	Air Flow		Pressure		Noise
	VDC	Amp	Watt	RPM	CFM	m3/min	mmH2O	inH2O	dB(A)
AXD8032V24LW-K	24	0.2	4.8	4000	49.9	1.413	8.51	0.335	46.8
AXD8032V24LR-K	24	0.34	8.16	5000	61.3	1.736	11.63	0.458	50.3
AXD8032V24L-K	24	0.48	11.5	6000	75.5	2.138	16.78	0.661	52
AXD8032V24M-K	24	0.62	14.9	7000	88.9	2.518	22.39	0.881	54.2
AXD8032V24H-K	24	0.76	18.2	8000	100.8	2.856	29.53	1.163	61.2
AXD8032V24HR-K	24	0.92	22.1	8500	107.1	3.034	32.9	1.295	63.5

DC Axial Fan

80x80x32mm

- Housing: Plastic (Flammability:UL94V-0)
- Impeller: Plastic (Flammability:UL94V-0)
- Bearing: Ball
- Certification: CE, RoHS
- Additional functions are optional



Model	Voltage	Current	Power	Speed	Air Flow		Pressure		Noise
	VDC	Amp	Watt	RPM	CFM	m3/min	mmH2O	inH2O	dB(A)
AXD8032V48LW-K	48	0.1	4.8	4000	49.9	1.413	8.51	0.335	46.8
AXD8032V48LR-K	48	0.17	8.16	5000	61.3	1.736	11.63	0.458	50.3
AXD8032V48L-K	48	0.24	11.5	6000	75.5	2.138	16.78	0.661	52
AXD8032V48M-K	48	0.31	14.9	7000	88.9	2.518	22.39	0.881	54.2
AXD8032V48H-K	48	0.38	18.2	8000	100.8	2.856	29.53	1.163	61.2
AXD8032V48HR-K	48	0.46	22.1	8500	107.1	3.034	32.9	1.295	63.5

DC Axial Fan

80x80x32mm

- Dimension:

Unit: mm

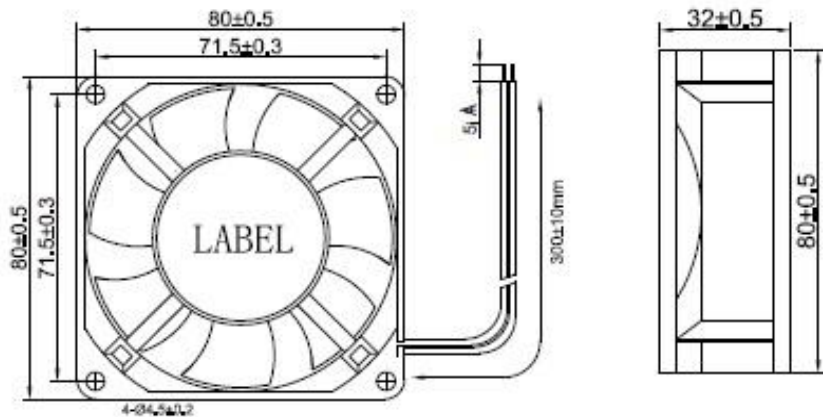

- Performance:

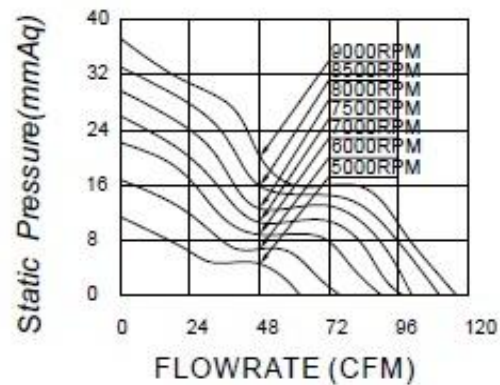

DC Axial Fan

80x80x38mm - B Type

- Housing: Plastic (Flammability:UL94V-0)
- Impeller: Plastic (Flammability:UL94V-0)
- Bearing: Ball
- Certification: CE, RoHS
- Additional functions are optional



Model	Voltage	Current	Power	Speed	Air Flow		Pressure		Noise
	VDC	Amp	Watt	RPM	CFM	m3/min	mmH2O	inH2O	dB(A)
AXD8038V12XL-K2	12	0.36	4.32	5000	66.46	1.882	12.65	0.498	46.6
AXD8038V12LW-K2	12	0.68	8.16	6000	79.1	2.24	18.22	0.717	51.4
AXD8038V12LR-K2	12	1	12	6500	85.3	2.416	20.49	0.807	54
AXD8038V12L-K2	12	1.32	15.8	7000	93.3	2.643	24.53	0.966	57.1
AXD8038V12M-K2	12	1.64	19.7	8000	105.6	2.99	32.03	1.261	60.2
AXD8038V12H-K2	12	2.04	24.5	8500	113.3	3.209	36.43	1.434	61.9
AXD8038V12HR-K2	12	2.36	28.3	9000	120.4	3.41	40.34	1.588	63.9
AXD8038V12HH-K2	12	2.68	32.2	9500	128.0	3.625	45.21	1.78	64.7
AXD8038V12XH-K2	12	3	36	10000	134.0	3.794	50.02	1.969	66.6

DC Axial Fan

80x80x38mm - B Type

- Housing: Plastic (Flammability:UL94V-0)
- Impeller: Plastic (Flammability:UL94V-0)
- Bearing: Ball
- Certification: CE, RoHS
- Additional functions are optional



Model	Voltage	Current	Power	Speed	Air Flow		Pressure		Noise
	VDC	Amp	Watt	RPM	CFM	m3/min	mmH2O	inH2O	dB(A)
AXD8038V24XL-K2	24	0.18	4.32	5000	66.5	1.882	12.65	0.498	46.6
AXD8038V24LW-K2	24	0.34	8.16	6000	79.1	2.24	18.22	0.717	51.4
AXD8038V24LR-K2	24	0.5	12	6500	85.3	2.416	20.49	0.807	54
AXD8038V24L-K2	24	0.66	15.8	7000	93.3	2.643	24.53	0.966	57.1
AXD8038V24M-K2	24	0.82	19.7	8000	105.6	2.99	32.03	1.261	60.2
AXD8038V24H-K2	24	1.02	24.5	8500	113.3	3.209	36.43	1.434	61.9
AXD8038V24HR-K2	24	1.18	28.3	9000	120.4	3.41	40.34	1.588	63.9
AXD8038V24HH-K2	24	1.34	32.2	9500	128.0	3.625	45.21	1.78	64.7
AXD8038V24XH-K2	24	1.5	36	10000	134.0	3.794	50.02	1.969	66.6

DC Axial Fan

80x80x38mm - B Type

- Housing: Plastic (Flammability:UL94V-0)
- Impeller: Plastic (Flammability:UL94V-0)
- Bearing: Ball
- Certification: CE, RoHS
- Additional functions are optional



Model	Voltage	Current	Power	Speed	Air Flow		Pressure		Noise
	VDC	Amp	Watt	RPM	CFM	m3/min	mmH2O	inH2O	dB(A)
AXD8038V48XL-K2	48	0.09	4.32	5000	66.5	1.882	12.65	0.498	46.6
AXD8038V48LW-K2	48	0.17	8.16	6000	79.1	2.24	18.22	0.717	51.4
AXD8038V48LR-K2	48	0.25	12	6500	85.3	2.416	20.49	0.807	54
AXD8038V48L-K2	48	0.33	15.8	7000	93.3	2.643	24.53	0.966	57.1
AXD8038V48M-K2	48	0.41	19.7	8000	105.6	2.99	32.03	1.261	60.2
AXD8038V48H-K2	48	0.51	24.5	8500	113.3	3.209	36.43	1.434	61.9
AXD8038V48HR-K2	48	0.59	28.3	9000	120.4	3.41	40.34	1.588	63.9
AXD8038V48HH-K2	48	0.67	32.2	9500	128.0	3.625	45.21	1.78	64.7
AXD8038V48XH-K2	48	0.75	36	10000	134.0	3.794	50.02	1.969	66.6

DC Axial Fan

80x80x38mm - B Type

- Dimension:

Unit: mm

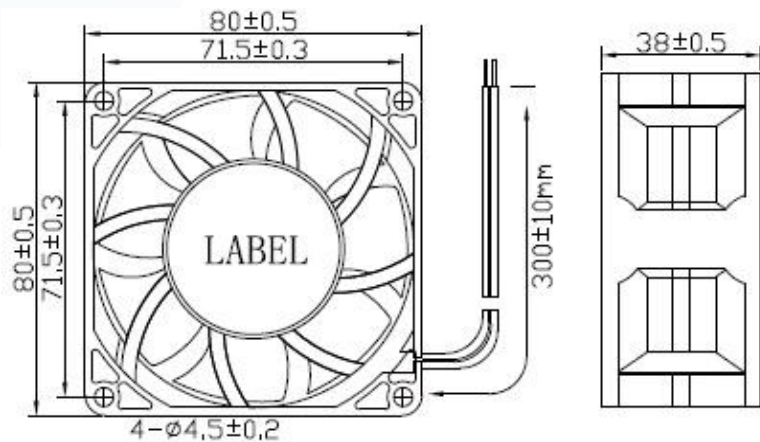

- Performance:

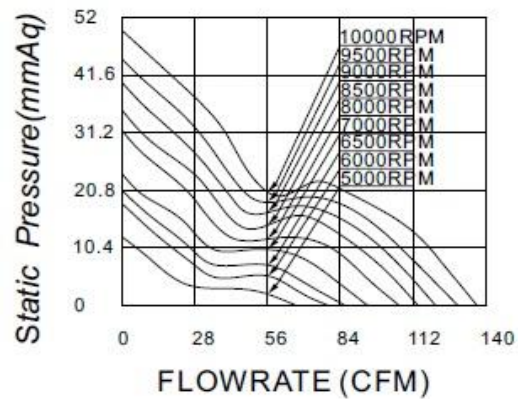

DC Axial Fan

80x80x38mm - C Type

- Housing: Plastic (Flammability:UL94V-0)
- Impeller: Plastic (Flammability:UL94V-0)
- Bearing: Ball
- Certification: CE, RoHS
- Additional functions are optional



Model	Voltage	Current	Power	Speed	Air Flow		Pressure		Noise
	VDC	Amp	Watt	RPM	CFM	m3/min	mmH2O	inH2O	dB(A)
AXD8038V12HR-K3	12	3.6	43.2	15000	129.22	3.66	127	5	70
AXD8038V24HR-K3	24	1.8	43.2	15000	129.22	3.66	127	5	70
AXD8038V48HR-K3	48	0.9	43.2	15000	129.22	3.66	127	5	70

DC Axial Fan

80x80x38mm - C Type

- Dimension:

Unit: mm

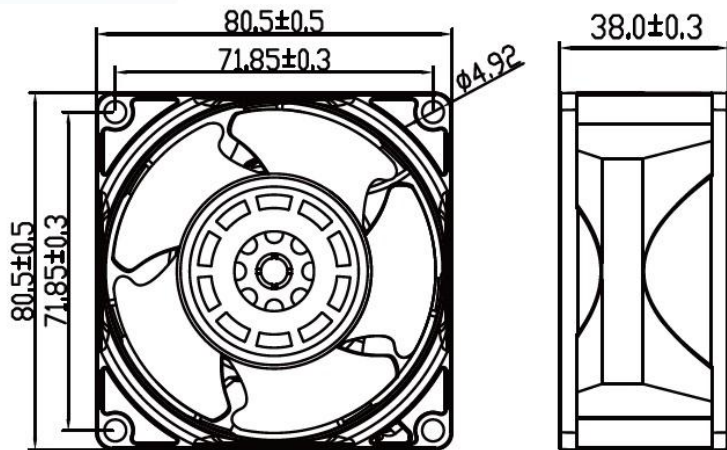

UNIT: $\frac{\text{mm}}{\text{(INCH)}}$

- Performance:

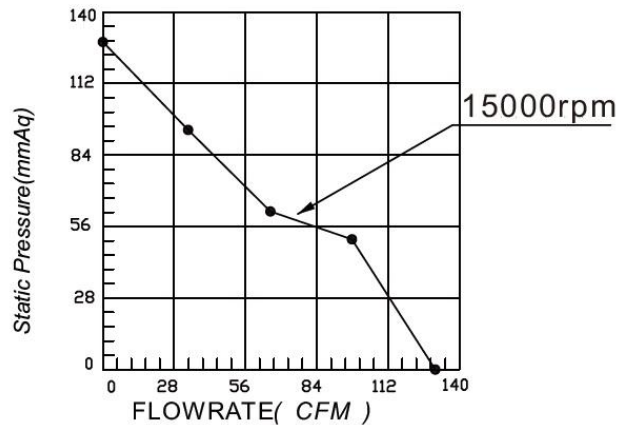

DC Axial Fan

92x92x25mm

- Housing: Plastic (Flammability:UL94V-0)
- Impeller: Plastic (Flammability:UL94V-0)
- Bearing: Ball
- Certification: CE, RoHS
- Additional functions are optional



Model	Voltage	Current	Power	Speed	Air Flow		Pressure		Noise
	VDC	Amp	Watt	RPM	CFM	m3/min	mmH2O	inH2O	dB(A)
AXD9225V12LW-K	12	0.12	1.44	2000	31.90	0.905	2.01	0.079	27.5
AXD9225V12LR-K	12	0.16	1.92	2500	38.30	1.086	2.92	0.115	33.7
AXD9225V12L-K	12	0.2	2.4	3000	49.00	1.389	4.11	0.162	39.1
AXD9225V12M-K	12	0.24	2.88	3500	54.80	1.554	4.99	0.196	42.4
AXD9225V12H-K	12	0.32	3.84	4000	66.20	1.875	6.78	0.267	46.4
AXD9225V12HR-K	12	0.44	5.28	4500	73.90	2.094	8.32	0.328	50.1

DC Axial Fan

92x92x25mm

- Housing: Plastic (Flammability:UL94V-0)
- Impeller: Plastic (Flammability:UL94V-0)
- Bearing: Ball
- Certification: CE, RoHS
- Additional functions are optional



Model	Voltage	Current	Power	Speed	Air Flow		Pressure		Noise
	VDC	Amp	Watt	RPM	CFM	m3/min	mmH2O	inH2O	dB(A)
AXD9225V24LW-K	24	0.06	1.44	2000	31.90	0.905	2.01	0.079	27.5
AXD9225V24LR-K	24	0.08	1.92	2500	38.30	1.086	2.92	0.115	33.7
AXD9225V24L-K	24	0.1	2.4	3000	49.00	1.389	4.11	0.162	39.1
AXD9225V24M-K	24	0.12	2.88	3500	54.80	1.554	4.99	0.196	42.4
AXD9225V24H-K	24	0.16	3.84	4000	66.20	1.875	6.78	0.267	46.4
AXD9225V24HR-K	24	0.22	5.28	4500	73.90	2.094	8.32	0.328	50.1

DC Axial Fan

92x92x25mm

- Housing: Plastic (Flammability:UL94V-0)
- Impeller: Plastic (Flammability:UL94V-0)
- Bearing: Ball
- Certification: CE, RoHS
- Additional functions are optional



Model	Voltage	Current	Power	Speed	Air Flow		Pressure		Noise
	VDC	Amp	Watt	RPM	CFM	m3/min	mmH2O	inH2O	dB(A)
AXD9225V48LW-K	48	0.03	1.44	2000	31.90	0.905	2.01	0.079	27.5
AXD9225V48LR-K	48	0.04	1.92	2500	38.30	1.086	2.92	0.115	33.7
AXD9225V48L-K	48	0.05	2.4	3000	49.00	1.389	4.11	0.162	39.1
AXD9225V48M-K	48	0.06	2.88	3500	54.80	1.554	4.99	0.196	42.4
AXD9225V48H-K	48	0.08	3.84	4000	66.20	1.875	6.78	0.267	46.4
AXD9225V48HR-K	48	0.11	5.28	4500	73.90	2.094	8.32	0.328	50.1

DC Axial Fan

92x92x25mm

- Dimension:

Unit: mm

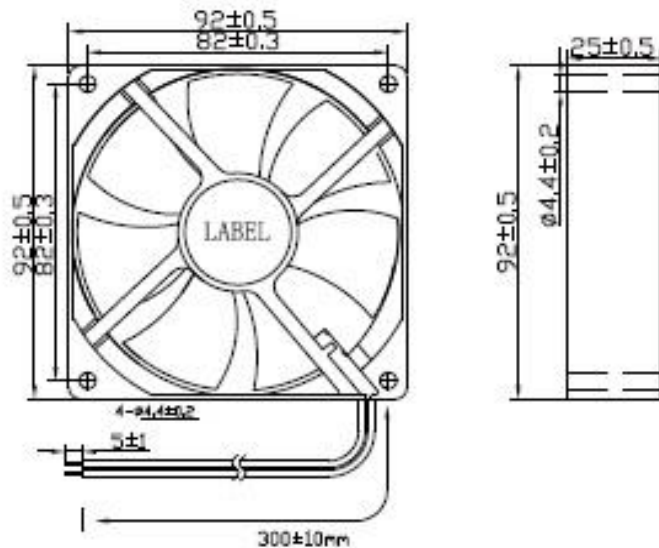

- Performance:

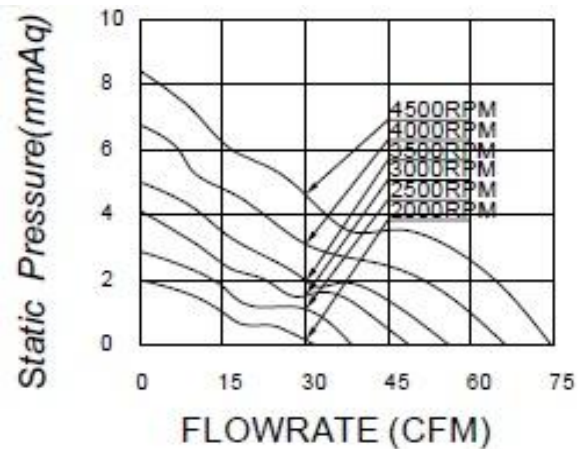

DC Axial Fan

92x92x25mm - E Type

- Housing: Plastic (Flammability:UL94V-0)
- Impeller: Plastic (Flammability:UL94V-0)
- Bearing: Ball
- Certification: CE, RoHS
- Additional functions are optional



Model	Voltage	Current	Power	Speed	Air Flow		Pressure		Noise
	VDC	Amp	Watt	RPM	CFM	m3/min	mmH2O	inH2O	dB(A)
AXD9225V12LW-K5	12	0.1	1.2	2500	45.70	1.295	3.41	0.134	29.7
AXD9225V12LR-K5	12	0.15	1.8	3000	54.60	1.546	4.98	0.196	34.3
AXD9225V12L-K5	12	0.18	2.16	3500	62.00	1.758	6.37	0.251	39.3
AXD9225V12M-K5	12	0.27	3.24	4000	67.70	1.919	7.99	0.315	41.9
AXD9225V12H-K5	12	0.43	5.16	4500	80.00	2.266	11.5	0.453	45
AXD9225V12HR-K5	12	0.47	5.64	5000	89.10	2.525	12.48	0.491	48

DC Axial Fan

92x92x25mm - E Type

- Housing: Plastic (Flammability:UL94V-0)
- Impeller: Plastic (Flammability:UL94V-0)
- Bearing: Ball
- Certification: CE, RoHS
- Additional functions are optional



Model	Voltage	Current	Power	Speed	Air Flow		Pressure		Noise
	VDC	Amp	Watt	RPM	CFM	m3/min	mmH2O	inH2O	dB(A)
AXD9225V24LW-K5	24	0.05	1.2	2500	45.70	1.295	3.41	0.134	29.7
AXD9225V24LR-K5	24	0.08	1.92	3000	54.60	1.546	4.98	0.196	34.3
AXD9225V24L-K5	24	0.09	2.16	3500	62.00	1.758	6.37	0.251	39.3
AXD9225V24M-K5	24	0.14	3.36	4000	67.70	1.919	7.99	0.315	41.9
AXD9225V24H-K5	24	0.22	5.28	4500	80.00	2.266	11.5	0.453	45
AXD9225V24HR-K5	24	0.24	5.76	5000	89.10	2.525	12.48	0.491	48

DC Axial Fan

92x92x25mm - E Type

- Housing: Plastic (Flammability:UL94V-0)
- Impeller: Plastic (Flammability:UL94V-0)
- Bearing: Ball
- Certification: CE, RoHS
- Additional functions are optional



Model	Voltage	Current	Power	Speed	Air Flow		Pressure		Noise
	VDC	Amp	Watt	RPM	CFM	m3/min	mmH2O	inH2O	dB(A)
AXD9225V48LW-K5	48	0.03	1.44	2500	45.70	1.295	3.41	0.134	29.7
AXD9225V48LR-K5	48	0.04	1.92	3000	54.60	1.546	4.98	0.196	34.3
AXD9225V48L-K5	48	0.05	2.4	3500	62.00	1.758	6.37	0.251	39.3
AXD9225V48M-K5	48	0.07	3.36	4000	67.70	1.919	7.99	0.315	41.9
AXD9225V48H-K5	48	0.11	5.28	4500	80.00	2.266	11.5	0.453	45
AXD9225V48HR-K5	48	0.12	5.76	5000	89.10	2.525	12.48	0.491	48

DC Axial Fan

92x92x25mm - E Type

- Dimension:

Unit: mm

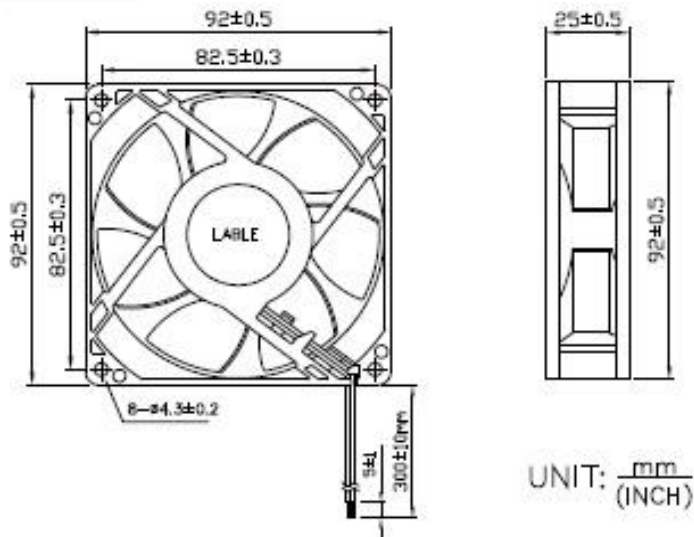

- Performance:

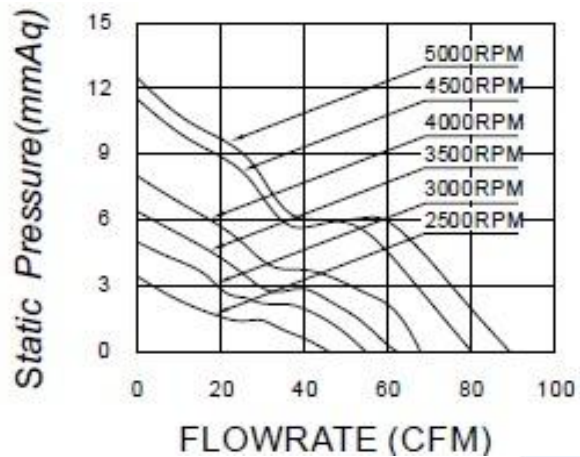

DC Axial Fan

92x92x38mm

- Housing: Plastic (Flammability:UL94V-0)
- Impeller: Plastic (Flammability:UL94V-0)
- Bearing: Ball
- Certification: CE, RoHS
- Additional functions are optional



Model	Voltage	Current	Power	Speed	Air Flow		Pressure		Noise
	VDC	Amp	Watt	RPM	CFM	m3/min	mmH2O	inH2O	dB(A)
AXD9238V12LR-K	12	0.5	6	3500	70.86	2.007	8.25	0.325	48
AXD9238V12L-K	12	0.9	10.8	4500	94.09	2.665	14.26	0.561	55.1
AXD9238V12M-K	12	1.2	14.4	5500	112.02	3.172	20.24	0.797	61.5
AXD9238V12H-K	12	1.6	19.2	6500	133.04	3.768	24.87	0.979	65.6
AXD9238V12HR-K	12	2.1	25.2	7000	144.26	4.086	30.88	1.216	66.2

DC Axial Fan

92x92x38mm

- Housing: Plastic (Flammability:UL94V-0)
- Impeller: Plastic (Flammability:UL94V-0)
- Bearing: Ball
- Certification: CE, RoHS
- Additional functions are optional



Model	Voltage	Current	Power	Speed	Air Flow		Pressure		Noise
	VDC	Amp	Watt	RPM	CFM	m3/min	mmH2O	inH2O	dB(A)
AXD9238V24LR-K	24	0.25	6	3500	70.86	2.007	8.25	0.325	48
AXD9238V24L-K	24	0.45	10.8	4500	94.09	2.665	14.26	0.561	55.1
AXD9238V24M-K	24	0.6	14.4	5500	112.02	3.172	20.24	0.797	61.5
AXD9238V24H-K	24	0.8	19.2	6500	133.04	3.768	24.87	0.979	65.6
AXD9238V24HR-K	24	1.05	25.2	7000	144.26	4.086	30.88	1.216	66.2

DC Axial Fan

92x92x38mm

- Housing: Plastic (Flammability:UL94V-0)
- Impeller: Plastic (Flammability:UL94V-0)
- Bearing: Ball
- Certification: CE, RoHS
- Additional functions are optional



Model	Voltage	Current	Power	Speed	Air Flow		Pressure		Noise
	VDC	Amp	Watt	RPM	CFM	m3/min	mmH2O	inH2O	dB(A)
AXD9238V48LR-K	48	0.13	6	3500	70.86	2.007	8.25	0.325	48
AXD9238V48L-K	48	0.23	10.8	4500	94.09	2.665	14.26	0.561	55.1
AXD9238V48M-K	48	2.36	14.4	5500	112.02	3.172	20.24	0.797	61.5
AXD9238V48H-K	48	0.4	19.2	6500	133.04	3.768	24.87	0.979	65.6
AXD9238V48HR-K	48	0.53	25.2	7000	144.26	4.086	30.88	1.216	66.2

DC Axial Fan

92x92x38mm

- Dimension:

Unit: mm

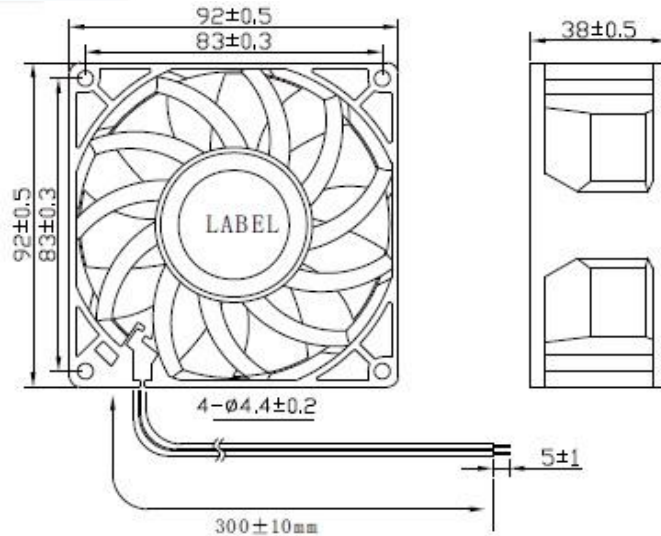

- Performance:

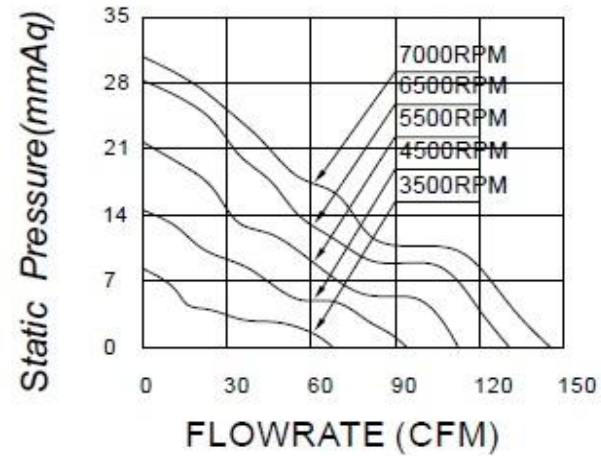

DC Axial Fan

92x92x38mm - F Type

- Housing: Plastic (Flammability:UL94V-0)
- Impeller: Plastic (Flammability:UL94V-0)
- Bearing: Ball
- Certification: CE, RoHS
- Additional functions are optional



Model	Voltage	Current	Power	Speed	Air Flow		Pressure		Noise
	VDC	Amp	Watt	RPM	CFM	m3/min	mmH2O	inH2O	dB(A)
AXD9238V12H-K6	12	3.5	42	11000	184.2	5.22	71.9	2.832	70.5
AXD9238V24H-K6	24	1.75	42	11000	184.2	5.22	71.9	2.832	70.5
AXD9238V48H-K6	48	0.875	42	11000	184.2	5.22	71.9	2.832	70.5

DC Axial Fan

92x92x38mm - F Type

- Dimension:

Unit: mm

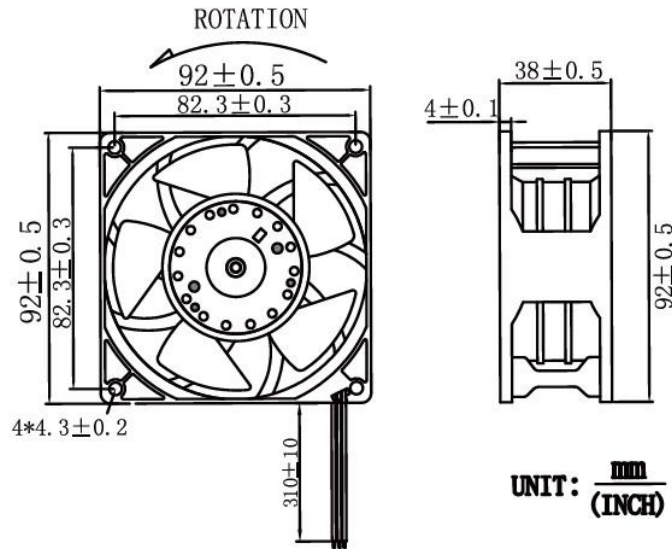

- Performance:

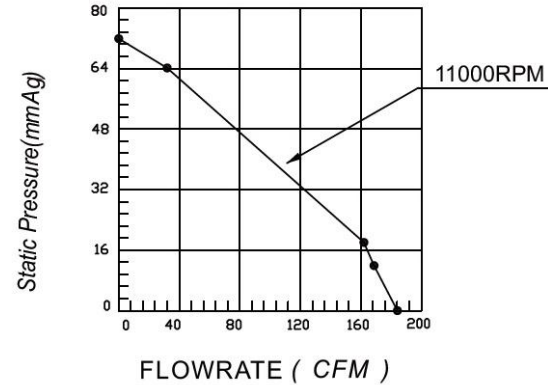

DC Axial Fan

Ø92x38mm - E Type

- Housing: Plastic (Flammability:UL94V-0)
- Impeller: Plastic (Flammability:UL94V-0)
- Bearing: Ball
- Certification: CE, RoHS
- Additional functions are optional



Model	Voltage	Current	Power	Speed	Air Flow		Pressure		Noise
	VDC	Amp	Watt	RPM	CFM	m3/min	mmH2O	inH2O	dB(A)
AXD9238V12L-K5	12	0.17	2	5500	42.4	1.2	15	0.591	43
AXD9238V24L-K5	24	0.09	2.2	5500	42.4	1.2	15	0.591	43

DC Axial Fan

Ø92x38mm - E Type

- Dimension:

Unit: mm

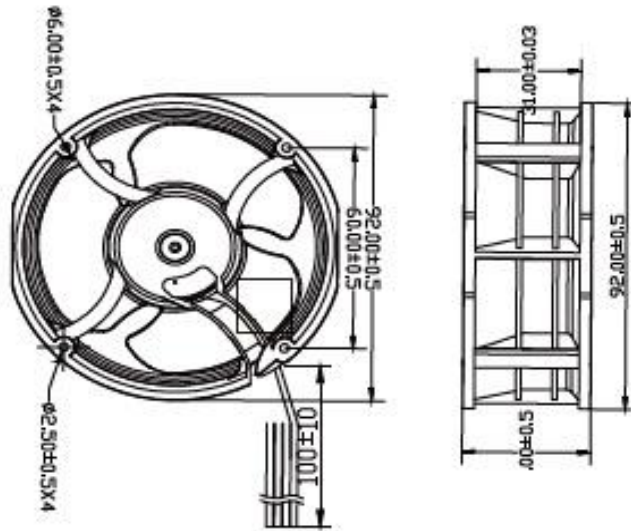

- Performance:

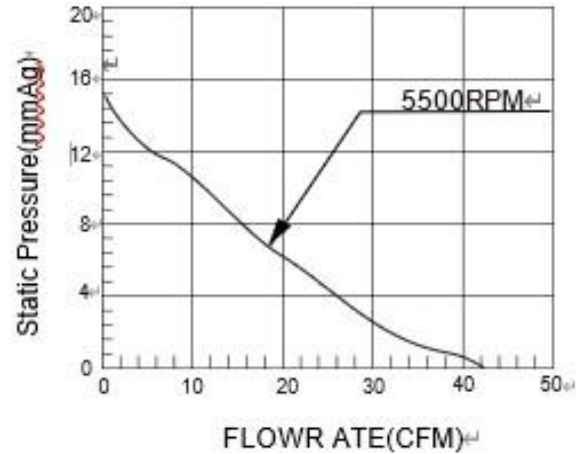

DC Axial Fan

120x120x25mm - C Type

- Housing: Plastic (Flammability:UL94V-0)
- Impeller: Plastic (Flammability:UL94V-0)
- Bearing: Ball
- Certification: CE, RoHS
- Additional functions are optional



Model	Voltage	Current	Power	Speed	Air Flow		Pressure		Noise
	VDC	Amp	Watt	RPM	CFM	m3/min	mmH2O	inH2O	dB(A)
AXD12025V12LR-K3	12	0.54	6.48	3100	103.12	2.92	6.59	0.259	46.6
AXD12025V12L-K3	12	0.62	7.44	3400	107.13	3.033	8.12	0.319	49.6
AXD12025V12M-K3	12	0.71	8.52	3700	129.18	3.657	9.63	0.379	51.4
AXD12025V12H-K3	12	0.84	10.08	4000	133.70	3.785	10.55	0.415	53.8
AXD12025V12HR-K3	12	1.2	14.4	4500	155.73	4.409	13.73	0.54	57.2

DC Axial Fan

120x120x25mm - C Type

- Housing: Plastic (Flammability:UL94V-0)
- Impeller: Plastic (Flammability:UL94V-0)
- Bearing: Ball
- Certification: CE, RoHS
- Additional functions are optional



Model	Voltage	Current	Power	Speed	Air Flow		Pressure		Noise
	VDC	Amp	Watt	RPM	CFM	m3/min	mmH2O	inH2O	dB(A)
AXD12025V24LR-K3	24	0.3	7.2	3100	103.12	2.92	6.59	0.259	46.6
AXD12025V24L-K3	24	0.31	7.44	3400	107.13	3.033	8.12	0.319	49.6
AXD12025V24M-K3	24	0.36	8.64	3700	129.18	3.657	9.63	0.379	51.4
AXD12025V24H-K3	24	0.42	10.08	4000	133.70	3.785	10.55	0.415	53.8
AXD12025V24HR-K3	24	0.6	14.4	4500	155.73	4.409	13.73	0.54	57.2

DC Axial Fan

120x120x25mm - C Type

- Housing: Plastic (Flammability:UL94V-0)
- Impeller: Plastic (Flammability:UL94V-0)
- Bearing: Ball
- Certification: CE, RoHS
- Additional functions are optional



Model	Voltage	Current	Power	Speed	Air Flow		Pressure		Noise
	VDC	Amp	Watt	RPM	CFM	m3/min	mmH2O	inH2O	dB(A)
AXD12025V48LR-K3	48	0.14	6.72	3100	103.12	2.92	6.59	0.259	46.6
AXD12025V48L-K3	48	0.16	7.68	3400	107.13	3.033	8.12	0.319	49.6
AXD12025V48M-K3	48	0.18	8.64	3700	129.18	3.657	9.63	0.379	51.4
AXD12025V48H-K3	48	0.21	10.08	4000	133.70	3.785	10.55	0.415	53.8
AXD12025V48HR-K3	48	0.3	14.4	4500	155.73	4.409	13.73	0.54	57.2

DC Axial Fan

120x120x25mm - C Type

- Dimension:

Unit: mm

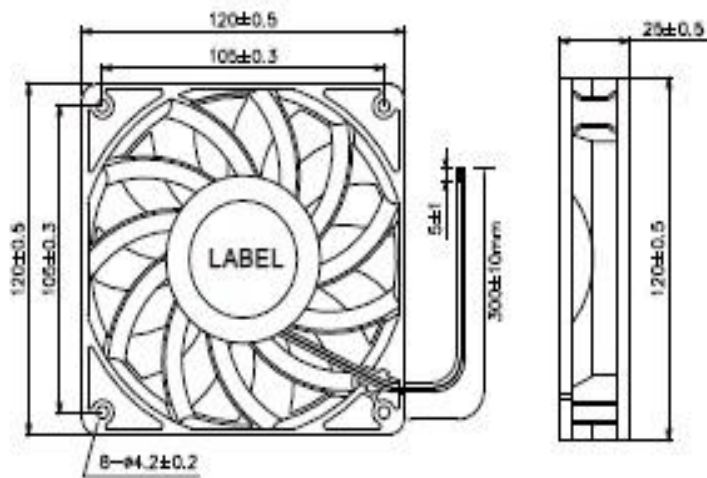

- Performance:

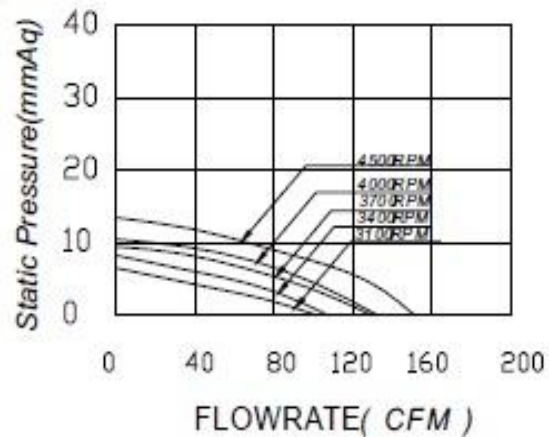

DC Axial Fan

120x120x32mm

- Housing: Plastic (Flammability:UL94V-0)
- Impeller: Plastic (Flammability:UL94V-0)
- Bearing: Ball
- Certification: CE, RoHS
- Additional functions are optional



Model	Voltage	Current	Power	Speed	Air Flow		Pressure		Noise
	VDC	Amp	Watt	RPM	CFM	m3/min	mmH2O	inH2O	dB(A)
AXD12032V12L-K	12	0.6	7.2	4000	116.20	3.29	13.8	0.54	56.1
AXD12032V12M-K	12	1	12	5000	142.1	4.02	21.5	0.85	63.6
AXD12032V12H-K	12	1.6	19.2	6000	166.9	4.72	30	1.18	65.8
AXD12032V24L-K	24	0.3	7.2	4000	116.20	3.29	13.8	0.54	56.1
AXD12032V24M-K	24	0.5	12	5000	142.1	4.02	21.5	0.85	63.6
AXD12032V24H-K	24	0.8	19.2	6000	166.9	4.72	30	1.18	65.8
AXD12032V48L-K	48	0.15	7.2	4000	116.20	3.29	13.8	0.54	56.1
AXD12032V48M-K	48	0.25	12	5000	142.1	4.02	21.5	0.85	63.6
AXD12032V48H-K	48	0.4	19.2	6000	166.9	4.72	30	1.18	65.8

DC Axial Fan

120x120x32mm

- Dimension:

Unit: mm

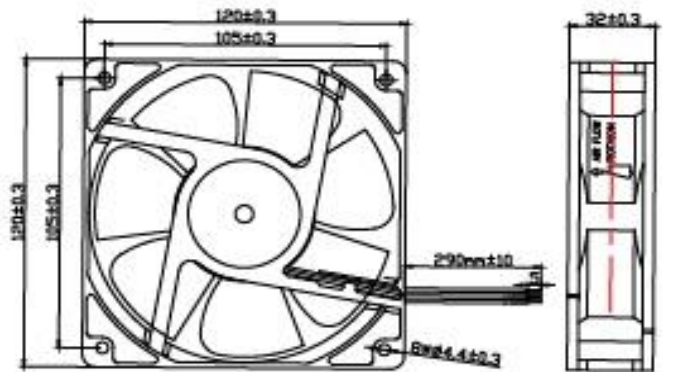

UNIT: $\frac{\text{mm}}{(\text{INCH})}$

- Performance:

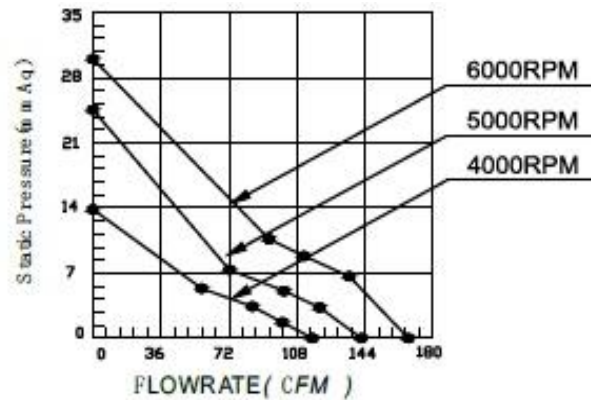

DC Axial Fan

120x120x38mm

- Housing: Plastic (Flammability:UL94V-0)
- Impeller: Plastic (Flammability:UL94V-0)
- Bearing: Ball
- Certification: CE, RoHS
- Additional functions are optional



Model	Voltage	Current	Power	Speed	Air Flow		Pressure		Noise
	VDC	Amp	Watt	RPM	CFM	m3/min	mmH2O	inH2O	dB(A)
AXD12038V12LW-K	12	0.3	3.6	2500	96.55	2.734	5.91	0.233	43.4
AXD12038V12LR-K	12	0.6	7.2	3000	111.26	3.151	8.66	0.341	47.7
AXD12038V12L-K	12	0.9	10.8	3500	132.14	3.742	11.94	0.47	52.8
AXD12038V12M-K	12	1.2	14.4	4000	152.89	4.33	15.46	0.609	54.5
AXD12038V12H-K	12	1.5	18	4500	169.37	4.797	19.73	0.777	58.1
AXD12038V12HR-K	12	1.8	21.6	5000	189.97	5.38	24.4	0.961	62.1
AXD12038V12HH-K	12	2	24	5500	209.92	5.945	29.28	1.153	65.2

DC Axial Fan

120x120x38mm

- Housing: Plastic (Flammability:UL94V-0)
- Impeller: Plastic (Flammability:UL94V-0)
- Bearing: Ball
- Certification: CE, RoHS
- Additional functions are optional



Model	Voltage	Current	Power	Speed	Air Flow		Pressure		Noise
	VDC	Amp	Watt	RPM	CFM	m3/min	mmH2O	inH2O	dB(A)
AXD12038V24LW-K	24	0.15	3.6	2500	96.55	2.734	5.91	0.233	43.4
AXD12038V24LR-K	24	0.3	7.2	3000	111.26	3.151	8.66	0.341	47.7
AXD12038V24L-K	24	0.45	10.8	3500	132.14	3.742	11.94	0.47	52.8
AXD12038V24M-K	24	0.6	14.4	4000	152.89	4.33	15.46	0.609	54.5
AXD12038V24H-K	24	0.75	18	4500	169.37	4.797	19.73	0.777	58.1
AXD12038V24HR-K	24	0.9	21.6	5000	189.97	5.38	24.4	0.961	62.1
AXD12038V24HH-K	24	1	24	5500	209.92	5.945	29.28	1.153	65.2

DC Axial Fan

120x120x38mm

- Housing: Plastic (Flammability:UL94V-0)
- Impeller: Plastic (Flammability:UL94V-0)
- Bearing: Ball
- Certification: CE, RoHS
- Additional functions are optional



Model	Voltage	Current	Power	Speed	Air Flow		Pressure		Noise
	VDC	Amp	Watt	RPM	CFM	m3/min	mmH2O	inH2O	dB(A)
AXD12038V48LW-K	48	0.075	3.6	2500	96.55	2.734	5.91	0.233	43.4
AXD12038V48LR-K	48	0.15	7.2	3000	111.26	3.151	8.66	0.341	47.7
AXD12038V48L-K	48	0.225	10.8	3500	132.14	3.742	11.94	0.47	52.8
AXD12038V48M-K	48	0.3	14.4	4000	152.89	4.33	15.46	0.609	54.5
AXD12038V48H-K	48	0.375	18	4500	169.37	4.797	19.73	0.777	58.1
AXD12038V48HR-K	48	0.45	21.6	5000	189.97	5.38	24.4	0.961	62.1
AXD12038V48HH-K	48	0.5	24	5500	209.92	5.945	29.28	1.153	65.2

DC Axial Fan

120x120x38mm

- Dimension:

Unit: mm

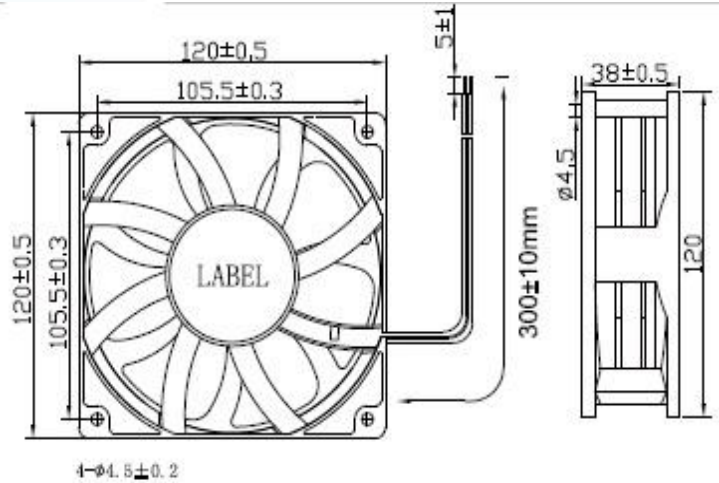

- Performance:

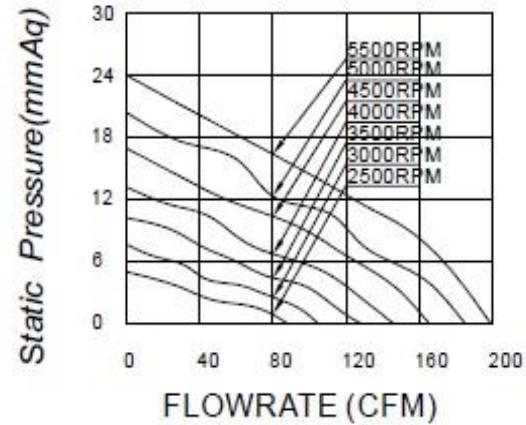

DC Axial Fan

120x120x38mm - B Type

- Housing: Plastic (Flammability:UL94V-0)
- Impeller: Plastic (Flammability:UL94V-0)
- Bearing: Ball
- Certification: CE, RoHS
- Additional functions are optional



Model	Voltage	Current	Power	Speed	Air Flow		Pressure		Noise
	VDC	Amp	Watt	RPM	CFM	m3/min	mmH2O	inH2O	dB(A)
AXD12038V12LW-K 2	12	0.35	4.2	2500	108.28	3.067	7.16	0.282	52.4
AXD12038V12LR-K 2	12	0.85	10.2	3000	131.62	3.728	10.43	0.411	56
AXD12038V12L-K2	12	1.38	16.6	3500	157.40	4.458	14.2	0.559	57.6
AXD12038V12M-K2	12	1.9	22.8	4000	179.80	5.092	18.15	0.715	62.4
AXD12038V12H-K2	12	2.4	28.8	4500	200.78	5.686	22.96	0.904	66.7
AXD12038V12HR-K 2	12	2.8	33.6	5000	225.59	6.389	28.02	1.103	69.8
AXD12038V12HH-K 2	12	3	36	5500	248.46	7.037	33.14	1.305	71.9

DC Axial Fan

120x120x38mm - B Type

- Housing: Plastic (Flammability:UL94V-0)
- Impeller: Plastic (Flammability:UL94V-0)
- Bearing: Ball
- Certification: CE, RoHS
- Additional functions are optional



Model	Voltage	Current	Power	Speed	Air Flow		Pressure		Noise
	VDC	Amp	Watt	RPM	CFM	m3/min	mmH2O	inH2O	dB(A)
AXD12038V24LW-K2	24	0.175	4.2	2500	108.28	3.067	7.16	0.282	52.4
AXD12038V24LR-K2	24	0.425	10.2	3000	131.62	3.728	10.43	0.411	56
AXD12038V24L-K2	24	0.7	16.6	3500	157.40	4.458	14.2	0.559	57.6
AXD12038V24M-K2	24	0.95	22.8	4000	179.80	5.092	18.15	0.715	62.4
AXD12038V24H-K2	24	1.2	28.8	4500	200.78	5.686	22.96	0.904	66.7
AXD12038V24HR-K2	24	1.4	33.6	5000	225.59	6.389	28.02	1.103	69.8
AXD12038V24HH-K2	24	1.5	36	5500	248.46	7.037	33.14	1.305	71.9

DC Axial Fan

120x120x38mm - B Type

- Housing: Plastic (Flammability:UL94V-0)
- Impeller: Plastic (Flammability:UL94V-0)
- Bearing: Ball
- Certification: CE, RoHS
- Additional functions are optional



Model	Voltage	Current	Power	Speed	Air Flow		Pressure		Noise
	VDC	Amp	Watt	RPM	CFM	m3/min	mmH2O	inH2O	dB(A)
AXD12038V48LW-K2	48	0.09	4.2	2500	108.28	3.067	7.16	0.282	52.4
AXD12038V48LR-K2	48	0.21	10.2	3000	131.62	3.728	10.43	0.411	56
AXD12038V48L-K2	48	0.345	16.6	3500	157.40	4.458	14.2	0.559	57.6
AXD12038V48M-K2	48	0.475	22.8	4000	179.80	5.092	18.15	0.715	62.4
AXD12038V48H-K2	48	0.6	28.8	4500	200.78	5.686	22.96	0.904	66.7
AXD12038V48HR-K2	48	0.7	33.6	5000	225.59	6.389	28.02	1.103	69.8
AXD12038V48HH-K2	48	0.75	36	5500	248.46	7.037	33.14	1.305	71.9

DC Axial Fan

120x120x38mm - B Type

- Dimension:

Unit: mm

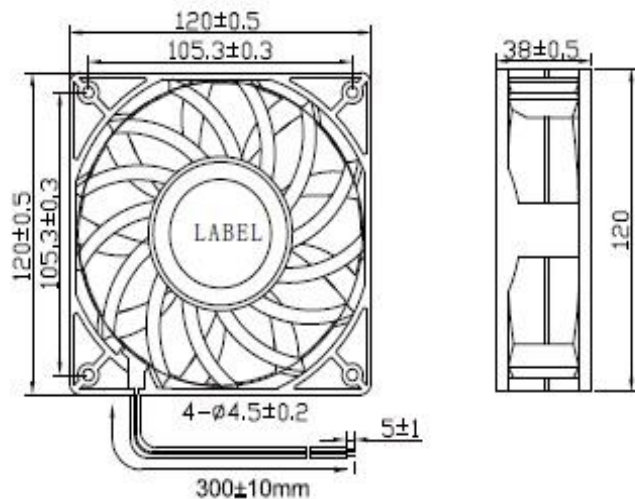

- Performance:

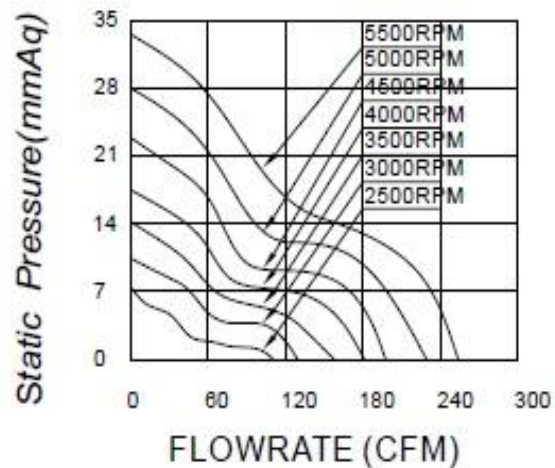

DC Axial Fan

120x120x38mm - F Type

- Housing: Plastic (Flammability:UL94V-0)
- Impeller: Plastic (Flammability:UL94V-0)
- Bearing: Ball
- Certification: CE, RoHS
- Additional functions are optional



Model	Voltage	Current	Power	Speed	Air Flow		Pressure		Noise
	VDC	Amp	Watt	RPM	CFM	m3/min	mmH2O	inH2O	dB(A)
AXD12038V12H-K6	12	4.8	57.6	10000	259.2	7.34	72.6	2.86	73.4
AXD12038V12HR-K6	12	6	72	11000	289.2	8.18	73.1	2.88	75.3
AXD12038V24H-K6	24	2.4	57.6	10000	259.2	7.34	72.6	2.86	73.4
AXD12038V24HR-K6	24	3	72	11000	289.2	8.18	73.1	2.88	75.3
AXD12038V48H-K6	48	1.2	57.6	10000	259.2	7.34	72.6	2.86	73.4
AXD12038V48HR-K6	48	1.5	72	11000	289.2	8.18	73.1	2.88	75.3

DC Axial Fan

120x120x38mm - F Type

- Dimension:

Unit: mm

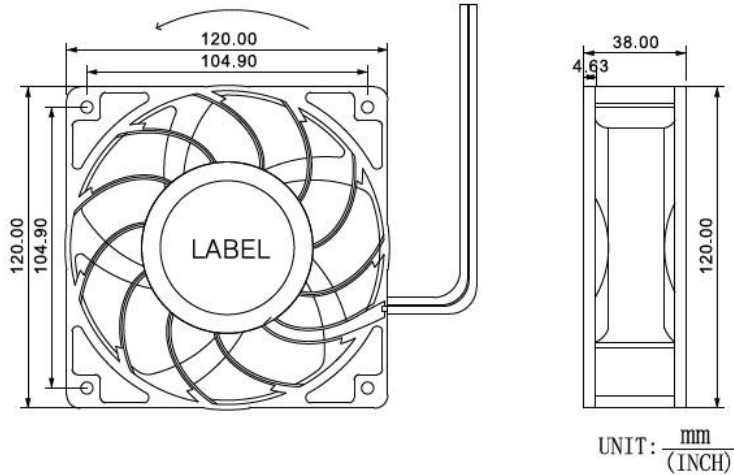

- Performance:

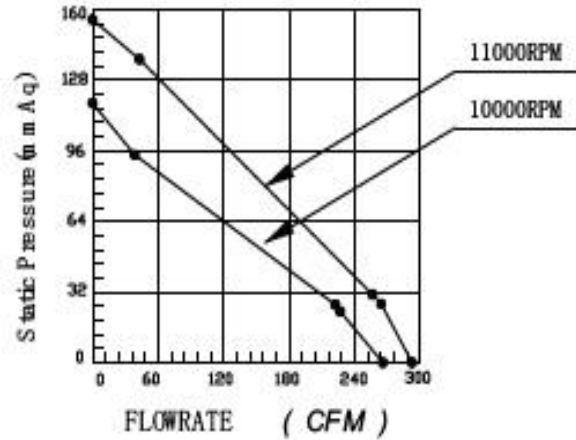

DC Axial Fan

140x140x25mm

- Housing: Plastic (Flammability:UL94V-0)
- Impeller: Plastic (Flammability:UL94V-0)
- Bearing: Ball
- Certification: CE, RoHS
- Additional functions are optional



Model	Voltage	Current	Power	Speed	Air Flow		Pressure		Noise
	VDC	Amp	Watt	RPM	CFM	m3/min	mmH2O	inH2O	dB(A)
AXD14025V12LR-K	12	0.1	1.2	1500	62.07	1.757	1.3	0.051	28
AXD14025V12L-K	12	0.23	2.76	2000	88.28	2.499	2.54	0.1	36
AXD14025V12M-K	12	0.47	5.64	2500	112.8	3.193	3.87	0.152	43.1
AXD14025V12H-K	12	1	12	2900	133.43	3.777	5.35	0.211	47.1

DC Axial Fan

140x140x25mm

- Housing: Plastic (Flammability:UL94V-0)
- Impeller: Plastic (Flammability:UL94V-0)
- Bearing: Ball
- Certification: CE, RoHS
- Additional functions are optional



Model	Voltage	Current	Power	Speed	Air Flow		Pressure		Noise
	VDC	Amp	Watt	RPM	CFM	m3/min	mmH2O	inH2O	dB(A)
AXD14025V24LR-K	24	0.05	1.2	1500	62.07	1.757	1.3	0.051	28
AXD14025V24L-K	24	0.12	2.88	2000	88.28	2.499	2.54	0.1	36
AXD14025V24M-K	24	0.24	5.76	2500	112.8	3.193	3.87	0.152	43.1
AXD14025V24H-K	24	0.5	12	2900	133.43	3.777	5.35	0.211	47.1

DC Axial Fan

140x140x25mm

- Housing: Plastic (Flammability:UL94V-0)
- Impeller: Plastic (Flammability:UL94V-0)
- Bearing: Ball
- Certification: CE, RoHS
- Additional functions are optional



Model	Voltage	Current	Power	Speed	Air Flow		Pressure		Noise
	VDC	Amp	Watt	RPM	CFM	m ³ /min	mmH ₂ O	inH ₂ O	dB(A)
AXD14025V48LR-K	48	0.03	1.44	1500	62.07	1.757	1.3	0.051	28
AXD14025V48L-K	48	0.06	2.88	2000	88.28	2.499	2.54	0.1	36
AXD14025V48M-K	48	0.12	5.76	2500	112.8	3.193	3.87	0.152	43.1
AXD14025V48H-K	48	0.25	12	2900	133.43	3.777	5.35	0.211	47.1

DC Axial Fan

140x140x25mm

- Dimension:

Unit: mm

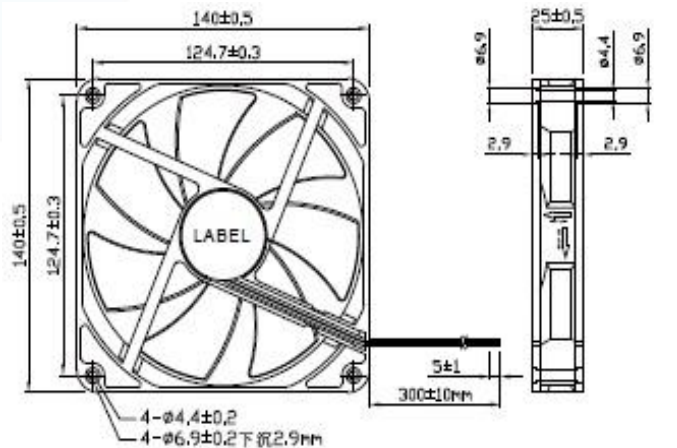

UNIT: $\frac{\text{mm}}{(\text{INCH})}$

- Performance:

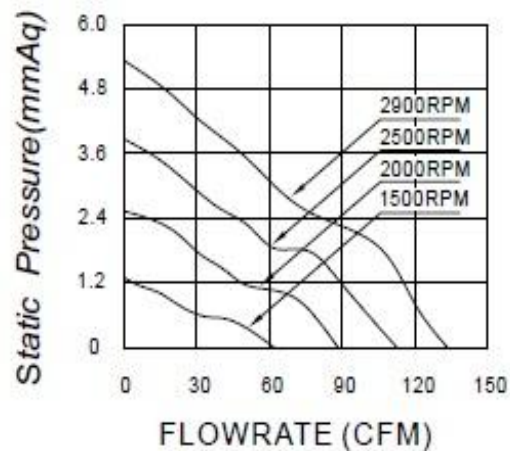

DC Axial Fan

140x140x38mm

- Housing: Plastic (Flammability:UL94V-0)
- Impeller: Plastic (Flammability:UL94V-0)
- Bearing: Ball
- Certification: CE, RoHS
- Additional functions are optional



Model	Voltage	Current	Power	Speed	Air Flow		Pressure		Noise
	VDC	Amp	Watt	RPM	CFM	m3/min	mmH2O	inH2O	dB(A)
AXD14038V12LW-K	12	0.39	4.68	1800	133.3	3.774	4.24	0.167	43.8
AXD14038V12LR-K	12	0.51	6.12	2000	152.11	4.306	5.66	0.223	47.5
AXD14038V12L-K	12	0.85	10.2	2500	191.13	5.411	8.74	0.344	53.5
AXD14038V12M-K	12	1.4	16.8	3000	230.73	6.532	12.4	0.488	58.2
AXD14038V12H-K	12	2.15	25.8	3500	268.37	7.598	16.35	0.644	62
AXD14038V12HR-K	12	3.25	39	4000	307.25	8.698	21.5	0.846	66.2

DC Axial Fan

140x140x38mm

- Housing: Plastic (Flammability:UL94V-0)
- Impeller: Plastic (Flammability:UL94V-0)
- Bearing: Ball
- Certification: CE, RoHS
- Additional functions are optional



Model	Voltage	Current	Power	Speed	Air Flow		Pressure		Noise
	VDC	Amp	Watt	RPM	CFM	m3/min	mmH2O	inH2O	dB(A)
AXD14038V24LW-K	24	0.2	4.8	1800	133.3	3.774	4.24	0.167	43.8
AXD14038V24LR-K	24	0.25	6	2000	152.11	4.306	5.66	0.223	47.5
AXD14038V24L-K	24	0.42	10.08	2500	191.13	5.411	8.74	0.344	53.5
AXD14038V24M-K	24	0.7	16.8	3000	230.73	6.532	12.4	0.488	58.2
AXD14038V24H-K	24	1.07	25.68	3500	268.37	7.598	16.35	0.644	62
AXD14038V24HR-K	24	1.63	39.12	4000	307.25	8.698	21.5	0.846	66.2

DC Axial Fan

140x140x38mm

- Housing: Plastic (Flammability:UL94V-0)
- Impeller: Plastic (Flammability:UL94V-0)
- Bearing: Ball
- Certification: CE, RoHS
- Additional functions are optional



Model	Voltage	Current	Power	Speed	Air Flow		Pressure		Noise
	VDC	Amp	Watt	RPM	CFM	m3/min	mmH2O	inH2O	dB(A)
AXD14038V48LW-K	48	0.1	4.8	1800	133.3	3.774	4.24	0.167	43.8
AXD14038V48LR-K	48	0.12	5.76	2000	152.11	4.306	5.66	0.223	47.5
AXD14038V48L-K	48	0.21	10.08	2500	191.13	5.411	8.74	0.344	53.5
AXD14038V48M-K	48	0.35	16.8	3000	230.73	6.532	12.4	0.488	58.2
AXD14038V48H-K	48	0.53	25.44	3500	268.37	7.598	16.35	0.644	62
AXD14038V48HR-K	48	0.81	38.88	4000	307.25	8.698	21.5	0.846	66.2

DC Axial Fan

140x140x38mm

- Dimension:

Unit: mm

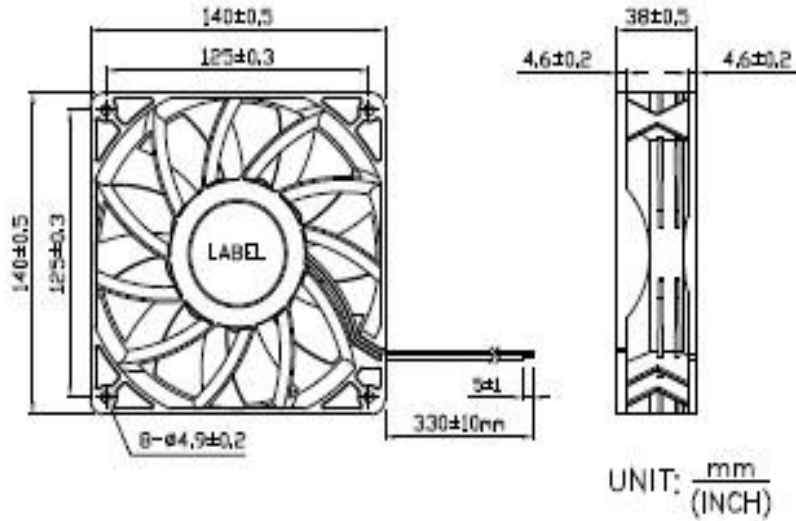

- Performance:

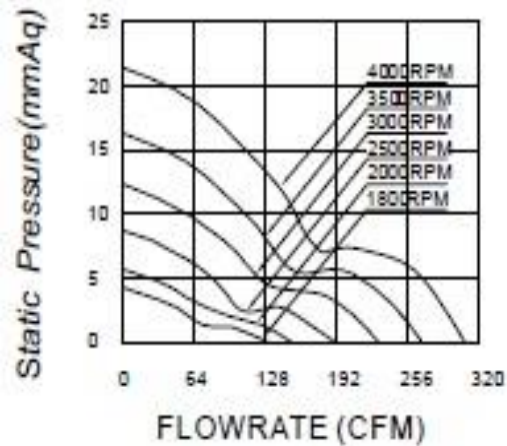

DC Axial Fan

Ø140x38mm - B Type

- Housing: Plastic (Flammability:UL94V-0)
- Impeller: Plastic (Flammability:UL94V-0)
- Bearing: Ball
- Certification: CE, RoHS
- Additional functions are optional



Model	Voltage	Current	Power	Speed	Air Flow		Pressure		Noise
	VDC	Amp	Watt	RPM	CFM	m3/min	mmH2O	inH2O	dB(A)
AXD14038V12L-K2	12	0.8	9.6	2550	145.16	4.11	5.73	0.23	46
AXD14038V24L-K2	24	0.4	9.6	2550	145.16	4.11	5.73	0.23	46
AXD14038V48L-K2	48	0.2	9.6	2550	145.16	4.11	5.73	0.23	46

DC Axial Fan

Ø140x38mm - B Type

- Dimension:

Unit: mm

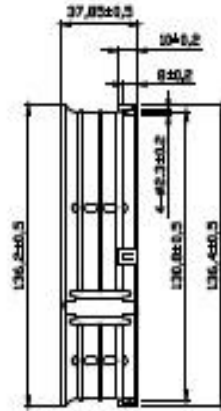
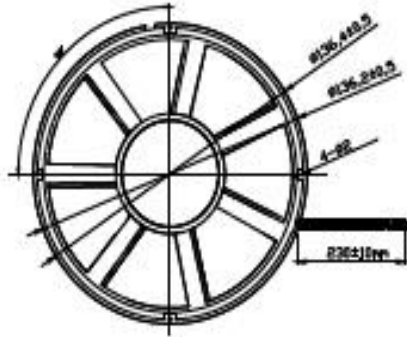

UNIT: $\frac{\text{mm}}{\text{(INCH)}}$

- Performance:

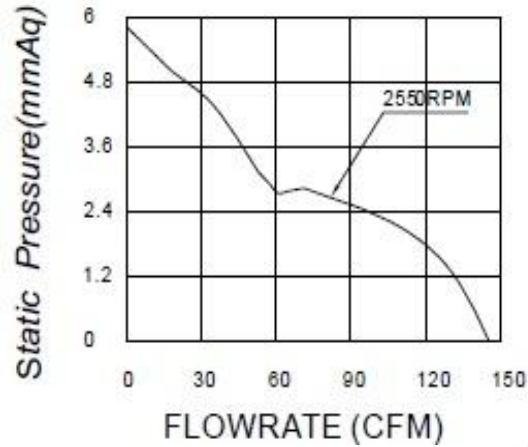

DC Axial Fan

140x140x38mm - D Type

- Housing: Plastic (Flammability:UL94V-0)
- Impeller: Plastic (Flammability:UL94V-0)
- Bearing: Ball
- Certification: CE, RoHS
- Additional functions are optional



Model	Voltage	Current	Power	Speed	Air Flow		Pressure		Noise
	VDC	Amp	Watt	RPM	CFM	m3/min	mmH2O	inH2O	dB(A)
AXD14038V12LW-K4	12	0.33	3.96	1900	117.1	3.314	5.2	0.209	38
AXD14038V12LR-K4	12	0.73	8.76	2600	159.2	4.505	9.4	0.378	46
AXD14038V12L-K4	12	2.24	26.88	3500	221.6	6.271	19.7	0.776	58.8
AXD14038V12M-K4	12	3.44	41.28	4500	282.6	7.998	30.3	1.193	67.5
AXD14038V12H-K4	12	5.2	62.4	5500	348.2	9.854	45.9	1.807	74
AXD14038V12HR-K4	12	6	72	6000	378.6	10.714	51.1	2.012	77.2

DC Axial Fan

140x140x38mm - D Type

- Housing: Plastic (Flammability:UL94V-0)
- Impeller: Plastic (Flammability:UL94V-0)
- Bearing: Ball
- Certification: CE, RoHS
- Additional functions are optional



Model	Voltage	Current	Power	Speed	Air Flow		Pressure		Noise
	VDC	Amp	Watt	RPM	CFM	m3/min	mmH2O	inH2O	dB(A)
AXD14038V24LW-K4	24	0.17	3.96	1900	117.1	3.314	5.2	0.209	38
AXD14038V24LR-K4	24	0.37	8.76	2600	159.2	4.505	9.4	0.378	46
AXD14038V24L-K4	24	1.12	26.88	3500	221.6	6.271	19.7	0.776	58.8
AXD14038V24M-K4	24	1.72	41.28	4500	282.6	7.998	30.3	1.193	67.5
AXD14038V24H-K4	24	2.6	62.4	5500	348.2	9.854	45.9	1.807	74
AXD14038V24HR-K4	24	3	72	6000	378.6	10.714	51.1	2.012	77.2

DC Axial Fan

140x140x38mm - D Type

- Housing: Plastic (Flammability:UL94V-0)
- Impeller: Plastic (Flammability:UL94V-0)
- Bearing: Ball
- Certification: CE, RoHS
- Additional functions are optional



Model	Voltage	Current	Power	Speed	Air Flow		Pressure		Noise
	VDC	Amp	Watt	RPM	CFM	m3/min	mmH2O	inH2O	dB(A)
AXD14038V48LW-K4	48	0.08	3.96	1900	117.1	3.314	5.2	0.209	38
AXD14038V48LR-K4	48	0.18	8.76	2600	159.2	4.505	9.4	0.378	46
AXD14038V48L-K4	48	0.56	26.88	3500	221.6	6.271	19.7	0.776	58.8
AXD14038V48M-K4	48	0.86	41.28	4500	282.6	7.998	30.3	1.193	67.5
AXD14038V48H-K4	48	1.3	62.4	5500	348.2	9.854	45.9	1.807	74
AXD14038V48HR-K4	48	1.5	72	6000	378.6	10.714	51.1	2.012	77.2

DC Axial Fan

140x140x38mm - D Type

- Dimension:

Unit: mm

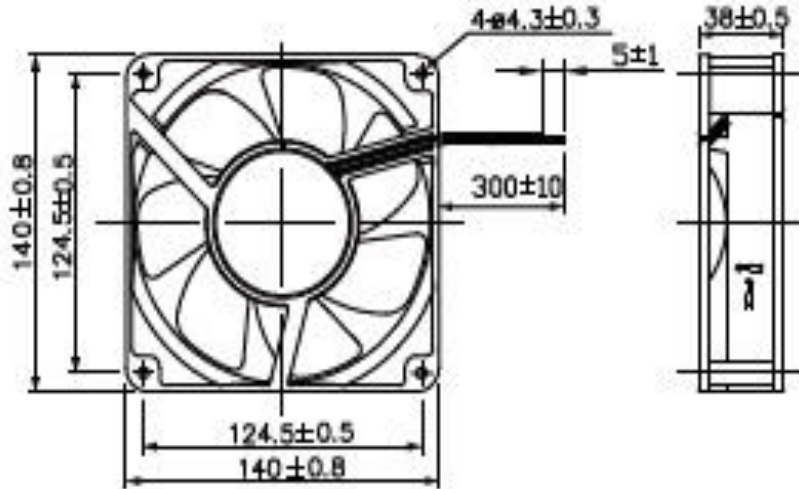

- Performance:

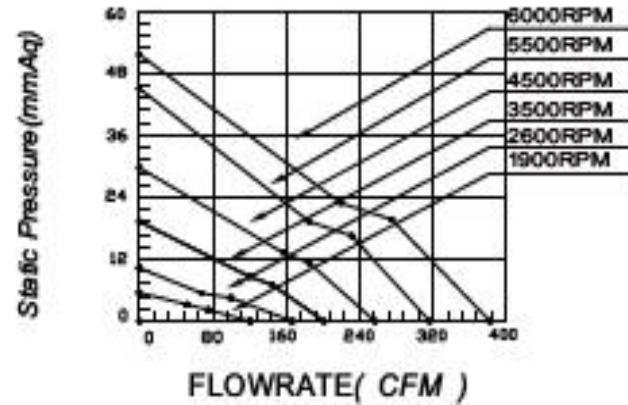

DC Axial Fan

150x150x50mm

- Housing: Plastic (Flammability:UL94V-0)
- Impeller: Plastic (Flammability:UL94V-0)
- Bearing: Ball
- Certification: CE, RoHS
- Additional functions are optional



Model	Voltage	Current	Power	Speed	Air Flow		Pressure		Noise
	VDC	Amp	Watt	RPM	CFM	m3/min	mmH2O	inH2O	dB(A)
AXD15050V12LW-K	12	0.8	9.6	2500	172.21	4.877	10.92	0.43	56.1
AXD15050V12LR-K	12	2.4	28.8	3000	209.4	5.93	15.33	0.604	58.3
AXD15050V12L-K	12	4.41	53	3500	248.09	7.026	21.33	0.84	62.5
AXD15050V12M-K	12	6	72	4000	283	8.015	27.36	1.077	65.5
AXD15050V12H-K	12	7.6	91.2	4500	325.57	9.22	37.57	1.479	68.2
AXD15050V12HR-K	12	10	120	5000	361.69	10.243	45.36	1.786	71.4

DC Axial Fan

150x150x50mm

- Housing: Plastic (Flammability:UL94V-0)
- Impeller: Plastic (Flammability:UL94V-0)
- Bearing: Ball
- Certification: CE, RoHS
- Additional functions are optional



Model	Voltage	Current	Power	Speed	Air Flow		Pressure		Noise
	VDC	Amp	Watt	RPM	CFM	m3/min	mmH2O	inH2O	dB(A)
AXD15050V24LW-K	24	0.4	9.6	2500	172.21	4.877	10.92	0.43	56.1
AXD15050V24LR-K	24	1.2	28.8	3000	209.4	5.93	15.33	0.604	58.3
AXD15050V24L-K	24	2.2	53	3500	248.09	7.026	21.33	0.84	62.5
AXD15050V24M-K	24	3	72	4000	283	8.015	27.36	1.077	65.5
AXD15050V24H-K	24	3.8	91.2	4500	325.57	9.22	37.57	1.479	68.2
AXD15050V24HR-K	24	5	120	5000	361.69	10.243	45.36	1.786	71.4

DC Axial Fan

150x150x50mm

- Housing: Plastic (Flammability:UL94V-0)
- Impeller: Plastic (Flammability:UL94V-0)
- Bearing: Ball
- Certification: CE, RoHS
- Additional functions are optional



Model	Voltage	Current	Power	Speed	Air Flow		Pressure		Noise
	VDC	Amp	Watt	RPM	CFM	m3/min	mmH2O	inH2O	dB(A)
AXD15050V48LW-K	48	0.2	9.6	2500	172.21	4.877	10.92	0.43	56.1
AXD15050V48LR-K	48	0.6	28.8	3000	209.4	5.93	15.33	0.604	58.3
AXD15050V48L-K	48	1.1	53	3500	248.09	7.026	21.33	0.84	62.5
AXD15050V48M-K	48	1.5	72	4000	283	8.015	27.36	1.077	65.5
AXD15050V48H-K	48	1.9	91.2	4500	325.57	9.22	37.57	1.479	68.2
AXD15050V48HR-K	48	2.5	120	5000	361.69	10.243	45.36	1.786	71.4

DC Axial Fan

150x150x50mm

- Dimension:

Unit: mm

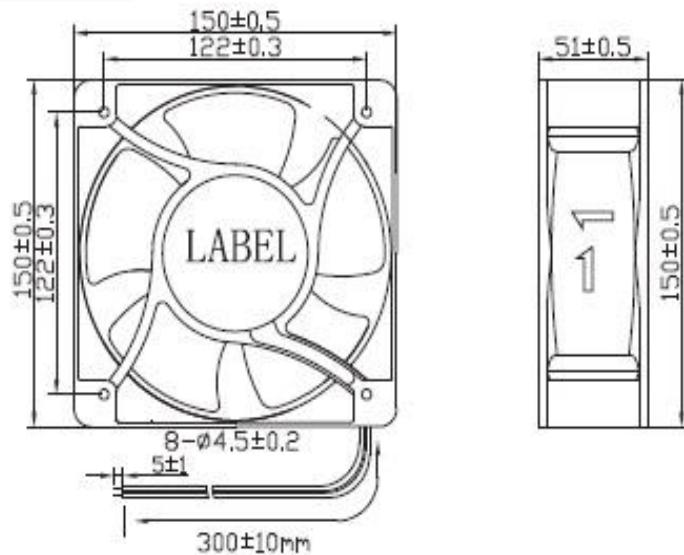

- Performance:

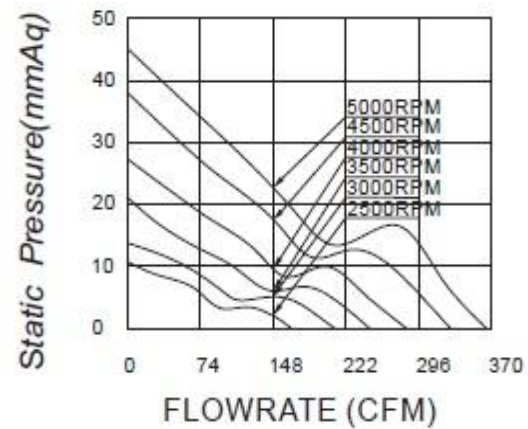

DC Axial Fan

172x150x25mm

- Housing: Plastic (Flammability:UL94V-0)
- Impeller: Plastic (Flammability:UL94V-0)
- Bearing: Ball
- Certification: CE, RoHS
- Additional functions are optional



Model	Voltage	Current	Power	Speed	Air Flow		Pressure		Noise
	VDC	Amp	Watt	RPM	CFM	m3/min	mmH2O	inH2O	dB(A)
AXD17225V12LR-K	12	0.56	6.72	2400	145.16	4.11	6.92	0.272	48.1
AXD17225V12L-K	12	0.76	9.12	2700	159.2	4.508	8.79	0.346	51
AXD17225V12M-K	12	0.98	11.76	3000	181.22	5.313	10.47	0.412	54.1
AXD17225V12H-K	12	1.17	14.04	3200	192.68	5.456	12.11	0.476	55.7
AXD17225V12HR-K	12	3	36	4000	246.03	6.966	18.74	0.737	62.9

DC Axial Fan

172x150x25mm

- Housing: Plastic (Flammability:UL94V-0)
- Impeller: Plastic (Flammability:UL94V-0)
- Bearing: Ball
- Certification: CE, RoHS
- Additional functions are optional



Model	Voltage	Current	Power	Speed	Air Flow		Pressure		Noise
	VDC	Amp	Watt	RPM	CFM	m3/min	mmH2O	inH2O	dB(A)
AXD17225V24LR-K	24	0.31	7.44	2400	145.16	4.11	6.92	0.272	48.1
AXD17225V24L-K	24	0.4	9.6	2700	159.2	4.508	8.79	0.346	51
AXD17225V24M-K	24	0.5	12	3000	181.22	5.313	10.47	0.412	54.1
AXD17225V24H-K	24	0.62	14.88	3200	192.68	5.456	12.11	0.476	55.7
AXD17225V24HR-K	24	1.6	38.4	4000	246.03	6.966	18.74	0.737	62.9

DC Axial Fan

172x150x25mm

- Housing: Plastic (Flammability:UL94V-0)
- Impeller: Plastic (Flammability:UL94V-0)
- Bearing: Ball
- Certification: CE, RoHS
- Additional functions are optional



Model	Voltage	Current	Power	Speed	Air Flow		Pressure		Noise
	VDC	Amp	Watt	RPM	CFM	m3/min	mmH2O	inH2O	dB(A)
AXD17225V48LR-K	48	0.17	8.16	2400	145.16	4.11	6.92	0.272	48.1
AXD17225V48L-K	48	0.22	10.56	2700	159.2	4.508	8.79	0.346	51
AXD17225V48M-K	48	0.27	12.96	3000	181.22	5.313	10.47	0.412	54.1
AXD17225V48H-K	48	0.31	14.88	3200	192.68	5.456	12.11	0.476	55.7
AXD17225V48HR-K	48	0.8	38.4	4000	246.03	6.966	18.74	0.737	62.9

DC Axial Fan

172x150x25mm

• Dimension:

Unit: mm

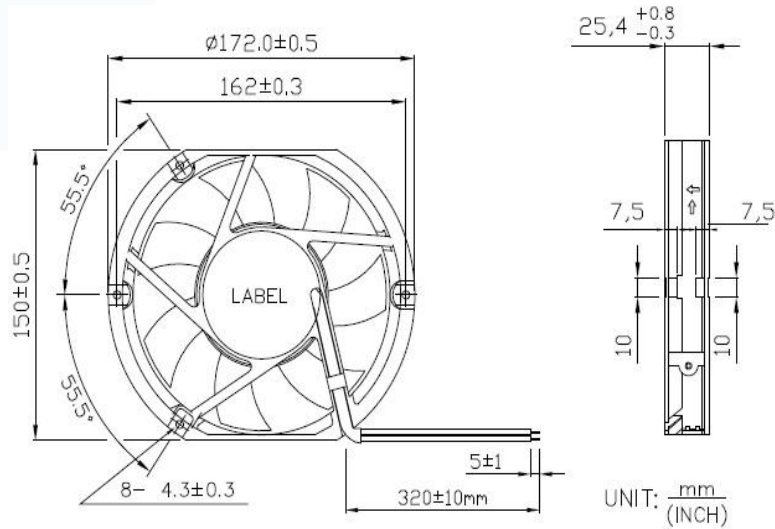

• Performance:

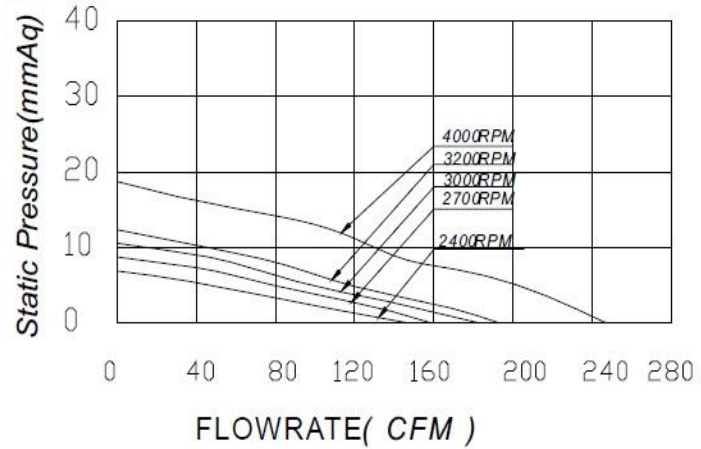

DC Axial Fan

172x150x38mm

- Housing: Aluminum
- Impeller: Plastic
- Bearing: Ball Type
- Certification: CE, RoHS
- Additional functions are optional



Model	Voltage	Current	Power	Speed	Air Flow		Pressure		Noise
	VDC	Amp	Watt	RPM	CFM	m3/min	mmH2O	inH2O	dB(A)
AXD17238V12LR-K	12	0.76	9.12	3000	222.17	6.287	16.38	0.645	60.9
AXD17238V12L-K	12	0.98	11.76	3500	257.17	7.278	21.34	0.84	64.3
AXD17238V12M-K	12	1.17	14.04	4000	297.16	8.41	27.94	1.1	68.4
AXD17238V12H-K	12	3	36	4600	332.18	9.401	34.21	1.347	71.2

DC Axial Fan

172x150x38mm

- Housing: Aluminum
- Impeller: Plastic
- Bearing: Ball Type
- Certification: CE, RoHS
- Additional functions are optional



Model	Voltage	Current	Power	Speed	Air Flow		Pressure		Noise
	VDC	Amp	Watt	RPM	CFM	m3/min	mmH2O	inH2O	dB(A)
AXD17238V24LR-K	24	0.4	9.6	3000	222.17	6.287	16.38	0.645	60.9
AXD17238V24L-K	24	0.5	12	3500	257.17	7.278	21.34	0.84	64.3
AXD17238V24M-K	24	0.62	14.88	4000	297.16	8.41	27.94	1.1	68.4
AXD17238V24H-K	24	1.6	38.4	4600	332.18	9.401	34.21	1.347	71.2

DC Axial Fan

172x150x38mm

- Housing: Aluminum
- Impeller: Plastic
- Bearing: Ball Type
- Certification: CE, RoHS
- Additional functions are optional



Model	Voltage	Current	Power	Speed	Air Flow		Pressure		Noise
	VDC	Amp	Watt	RPM	CFM	m3/min	mmH2O	inH2O	dB(A)
AXD17238V48LR-K	48	0.22	10.56	3000	222.17	6.287	16.38	0.645	60.9
AXD17238V48L-K	48	0.27	12.96	3500	257.17	7.278	21.34	0.84	64.3
AXD17238V48M-K	48	0.31	14.88	4000	297.16	8.41	27.94	1.1	68.4
AXD17238V48H-K	48	0.8	38.4	4600	332.18	9.401	34.21	1.347	71.2

DC Axial Fan

172x150x38mm

- Dimension:

Unit: mm

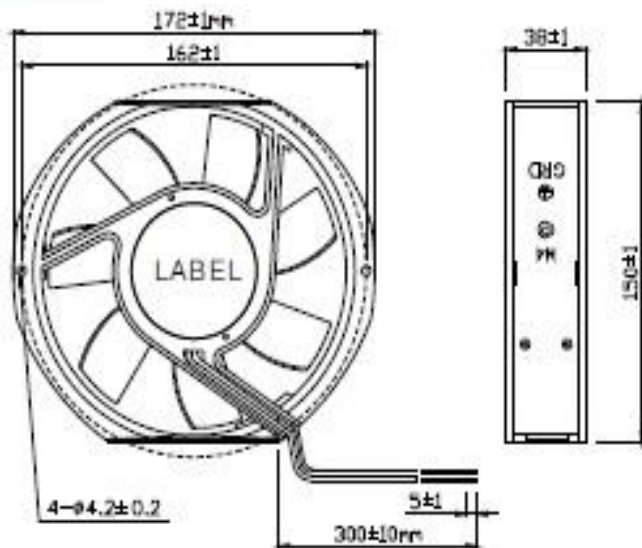

- Performance:

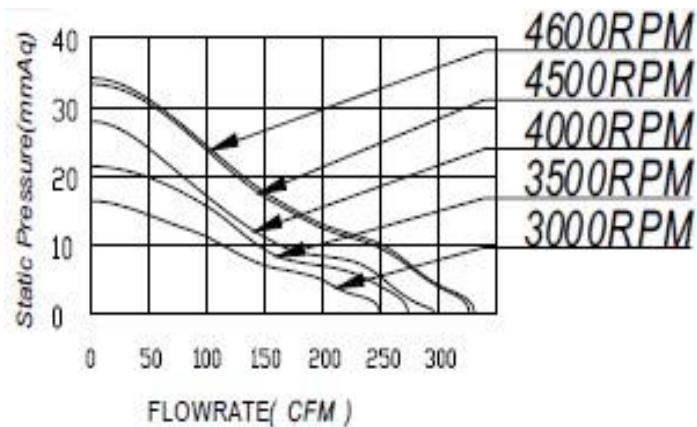

DC Axial Fan

172x150x51mm

- Housing: Aluminum
- Impeller: Plastic
- Bearing: Ball Type
- Certification: CE, RoHS
- Additional functions are optional



Model	Voltage	Current	Power	Speed	Air Flow		Pressure		Noise
	VDC	Amp	Watt	RPM	CFM	m3/min	mmH2O	inH2O	dB(A)
AXD17251V12LW-K	12	0.8	9.6	2500	172.21	4.877	10.92	0.43	56.1
AXD17251V12LR-K	12	2.4	28.8	3000	209.4	5.93	15.33	0.604	58.3
AXD17251V12L-K	12	4.41	53	3500	248.09	7.026	21.33	0.84	62.5
AXD17251V12M-K	12	6	72	4000	283	8.015	27.36	1.077	65.5
AXD17251V12H-K	12	7.6	91.2	4500	325.57	9.22	37.57	1.479	68.2
AXD17251V12HR-K	12	10	120	5000	361.69	10.243	45.36	1.786	71.4

DC Axial Fan

172x150x51mm

- Housing: Aluminum
- Impeller: Plastic
- Bearing: Ball Type
- Certification: CE, RoHS
- Additional functions are optional



Model	Voltage	Current	Power	Speed	Air Flow		Pressure		Noise
	VDC	Amp	Watt	RPM	CFM	m3/min	mmH2O	inH2O	dB(A)
AXD17251V24LW-K	24	0.4	9.6	2500	172.21	4.877	10.92	0.43	56.1
AXD17251V24LR-K	24	1.2	28.8	3000	209.4	5.93	15.33	0.604	58.3
AXD17251V24L-K	24	2.2	53	3500	248.09	7.026	21.33	0.84	62.5
AXD17251V24M-K	24	3	72	4000	283	8.015	27.36	1.077	65.5
AXD17251V24H-K	24	3.8	91.2	4500	325.57	9.22	37.57	1.479	68.2
AXD17251V24HR-K	24	5	120	5000	361.69	10.243	45.36	1.786	71.4

DC Axial Fan

172x150x51mm

- Housing: Aluminum
- Impeller: Plastic
- Bearing: Ball Type
- Certification: CE, RoHS
- Additional functions are optional



Model	Voltage	Current	Power	Speed	Air Flow		Pressure		Noise
	VDC	Amp	Watt	RPM	CFM	m3/min	mmH2O	inH2O	dB(A)
AXD17251V48LW-K	48	0.2	9.6	2500	172.21	4.877	10.92	0.43	56.1
AXD17251V48LR-K	48	0.6	28.8	3000	209.4	5.93	15.33	0.604	58.3
AXD17251V48L-K	48	1.1	53	3500	248.09	7.026	21.33	0.84	62.5
AXD17251V48M-K	48	1.5	72	4000	283	8.015	27.36	1.077	65.5
AXD17251V48H-K	48	1.9	91.2	4500	325.57	9.22	37.57	1.479	68.2
AXD17251V48HR-K	48	2.5	120	5000	361.69	10.243	45.36	1.786	71.4

DC Axial Fan

172x150x51mm

- Dimension:

Unit: mm

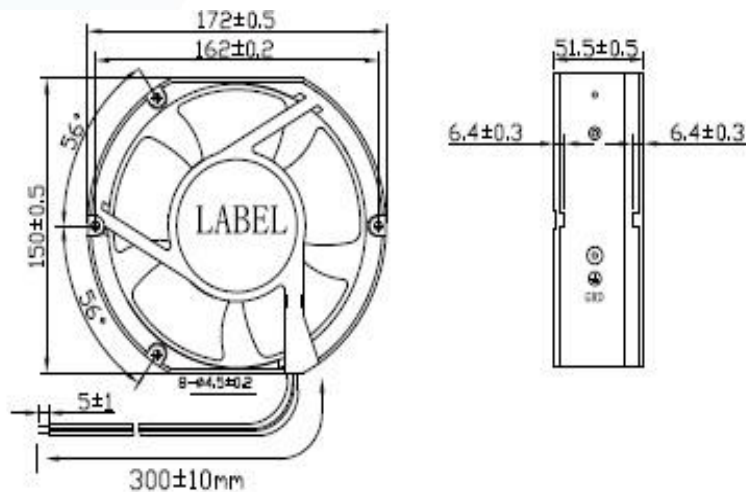

- Performance:

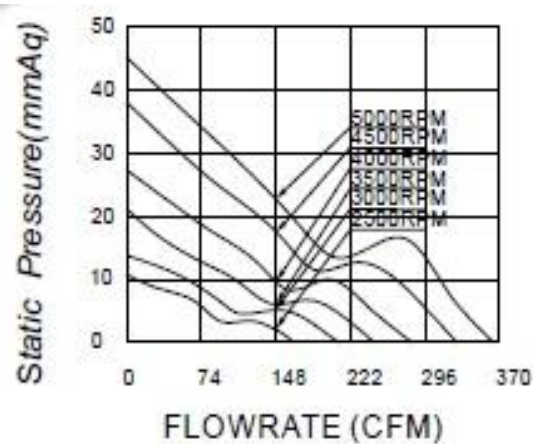

DC Axial Fan

172x150x51mm - B Type

- Housing: Aluminum
- Impeller: Plastic
- Bearing: Ball Type
- Certification: CE, RoHS
- Additional functions are optional



Model	Voltage	Current	Power	Speed	Air Flow		Pressure		Noise
	VDC	Amp	Watt	RPM	CFM	m3/min	mmH2O	inH2O	dB(A)
AXD17251V12H-K2	12	14	168	9500	603.20	17.07	158.02	6.22	70
AXD17251V24H-K2	24	7	168	9500	603.20	17.07	158.02	6.22	70
AXD17251V48H-K2	48	3.5	168	9500	603.20	17.07	158.02	6.22	70

DC Axial Fan

172x150x51mm - B Type

- Dimension:

Unit: mm

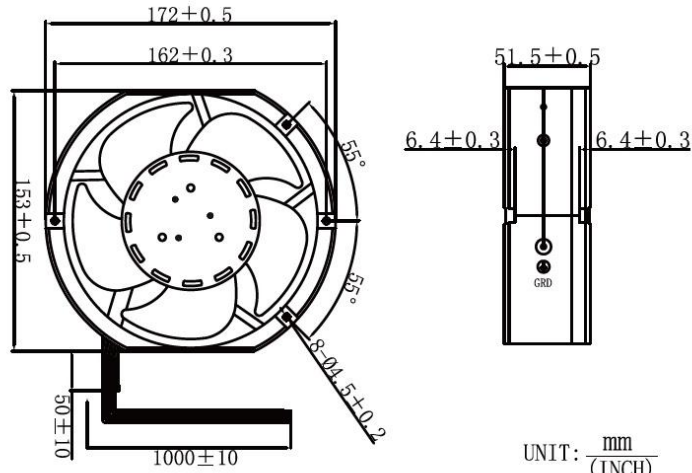

- Performance:

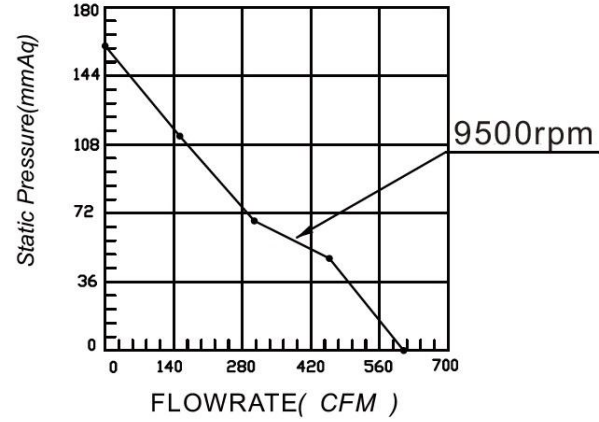

DC Axial Fan

Ø172x51mm - C Type

- Housing: Aluminum
- Impeller: Plastic
- Bearing: Ball Type
- Certification: CE, RoHS
- Additional functions are optional



Model	Voltage	Current	Power	Speed	Air Flow		Pressure		Noise
	VDC	Amp	Watt	RPM	CFM	m3/min	mmH2O	inH2O	dB(A)
AXD17251V12LR-K3	12	4	48	6000	347.10	9.83	52.9	2.08	68.3
AXD17251V12L-K3	12	5.5	66	6500	384.20	10.88	59.4	2.34	69.5
AXD17251V12M-K3	12	5.6	67.2	7000	416.40	11.79	71.5	2.82	70.5
AXD17251V12H-K3	12	7	84	7500	454.60	12.87	77.1	3.04	74.3

DC Axial Fan

Ø172x51mm - C Type

- Housing: Aluminum
- Impeller: Plastic
- Bearing: Ball Type
- Certification: CE, RoHS
- Additional functions are optional



Model	Voltage	Current	Power	Speed	Air Flow		Pressure		Noise
	VDC	Amp	Watt	RPM	CFM	m3/min	mmH2O	inH2O	dB(A)
AXD17251V24LR-K3	24	2	48	6000	347.10	9.83	52.9	2.08	68.3
AXD17251V24L-K3	24	2.75	66	6500	384.20	10.88	59.4	2.34	69.5
AXD17251V24M-K3	24	2.8	67.2	7000	416.40	11.79	71.5	2.82	70.5
AXD17251V24H-K3	24	3.5	84	7500	454.60	12.87	77.1	3.04	74.3
AXD17251V24HR-K3	24	6.4	153.6	9500	554.60	15.7	122.1	4.81	80.2

DC Axial Fan

Ø172x51mm - C Type

- Housing: Aluminum
- Impeller: Plastic
- Bearing: Ball Type
- Certification: CE, RoHS
- Additional functions are optional



Model	Voltage	Current	Power	Speed	Air Flow		Pressure		Noise
	VDC	Amp	Watt	RPM	CFM	m3/min	mmH2O	inH2O	dB(A)
AXD17251V48LR-K3	48	1	48	6000	347.10	9.83	52.9	2.08	68.3
AXD17251V48L-K3	48	1.375	66	6500	384.20	10.88	59.4	2.34	69.5
AXD17251V48M-K3	48	1.4	67.2	7000	416.40	11.79	71.5	2.82	70.5
AXD17251V48H-K3	48	1.75	84	7500	454.60	12.87	77.1	3.04	74.3
AXD17251V48HR-K3	48	3.2	153.6	9500	554.60	15.70	122.1	4.81	80.2

DC Axial Fan

Ø172x51mm - C Type

- Dimension:
Unit: mm

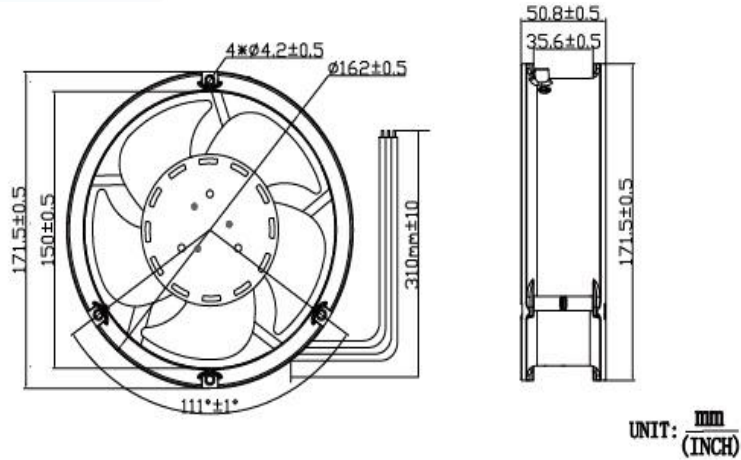

- Performance:

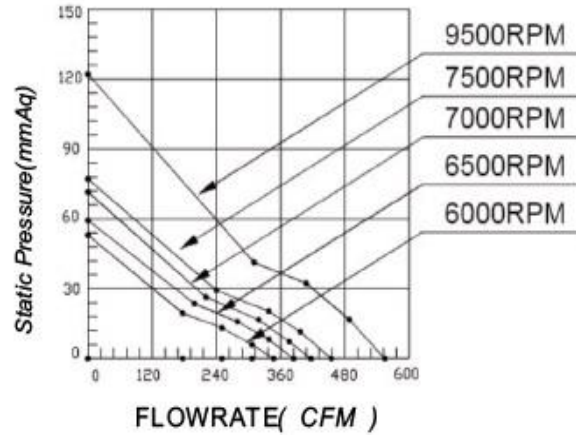

DC Axial Fan

200x200x60mm

- Housing: Aluminum
- Impeller: Plastic
- Bearing: Ball Type
- Certification: CE, RoHS
- Additional functions are optional



Model	Voltage	Current	Power	Speed	Air Flow		Pressure		Noise
	VDC	Amp	Watt	RPM	CFM	m3/min	mmH2O	inH2O	dB(A)
AXD20060V12LR-K	12	1.65	19.8	2000	400.58	11.38	6.65	0.262	54.6
AXD20060V12L-K	12	2.92	35.04	2500	513.39	14.585	12.15	0.478	60
AXD20060V12M-K	12	4.73	56.76	3000	586.69	16.673	17.28	0.68	63.6
AXD20060V12H-K	12	7.4	88.8	3500	645.61	18.341	22.02	0.867	68.5

DC Axial Fan

200x200x60mm

- Housing: Aluminum
- Impeller: Plastic
- Bearing: Ball Type
- Certification: CE, RoHS
- Additional functions are optional



Model	Voltage	Current	Power	Speed	Air Flow		Pressure		Noise
	VDC	Amp	Watt	RPM	CFM	m3/min	mmH2O	inH2O	dB(A)
AXD20060V24LR-K	24	0.78	18.82	2000	400.58	11.38	6.65	0.262	54.6
AXD20060V24L-K	24	1.39	33.36	2500	513.39	14.585	12.15	0.478	60
AXD20060V24M-K	24	2.25	54	3000	586.69	16.673	17.28	0.68	63.6
AXD20060V24H-K	24	3.52	84.38	3500	645.61	18.341	22.02	0.867	68.5

DC Axial Fan

200x200x60mm

- Housing: Aluminum
- Impeller: Plastic
- Bearing: Ball Type
- Certification: CE, RoHS
- Additional functions are optional



Model	Voltage	Current	Power	Speed	Air Flow		Pressure		Noise
	VDC	Amp	Watt	RPM	CFM	m3/min	mmH2O	inH2O	dB(A)
AXD20060V48LR-K	48	0.37	17.86	2000	400.58	11.38	6.65	0.262	54.6
AXD20060V48L-K	48	0.66	31.68	2500	513.39	14.585	12.15	0.478	60
AXD20060V48M-K	48	1.07	51.36	3000	586.69	16.673	17.28	0.68	63.6
AXD20060V48H-K	48	1.67	80.16	3500	645.61	18.341	22.02	0.867	68.5

DC Axial Fan

200x200x60mm

- Dimension:

Unit: mm

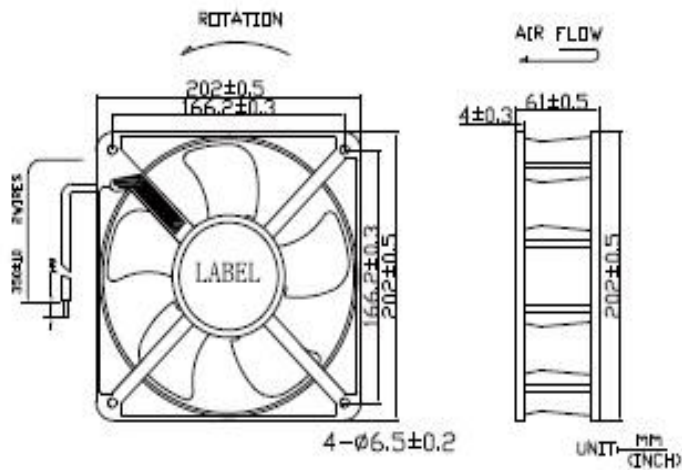

- Performance:

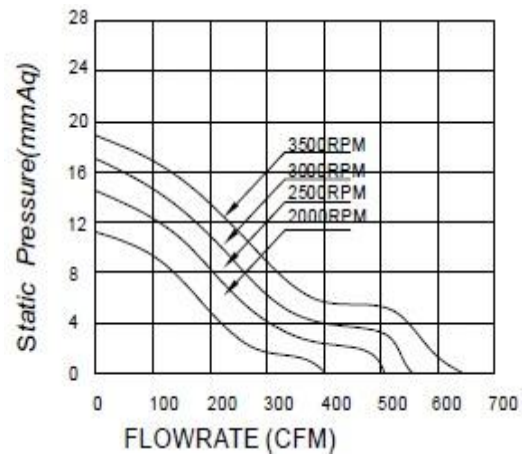

DC Axial Fan

Ø220x60mm

- Housing: Aluminum
- Impeller: Plastic
- Bearing: Ball Type
- Certification: CE, RoHS
- Additional functions are optional



Model	Voltage	Current	Power	Speed	Air Flow		Pressure		Noise
	VDC	Amp	Watt	RPM	CFM	m3/min	mmH2O	inH2O	dB(A)
AXD22060V12LR-K	12	1.65	19.8	2000	400.58	11.38	6.65	0.262	54.6
AXD22060V12L-K	12	2.92	35.04	2500	513.39	14.585	12.15	0.478	60
AXD22060V12M-K	12	4.73	56.76	3000	586.69	16.673	17.28	0.68	63.6
AXD22060V12H-K	12	7.4	88.8	3500	645.61	18.341	22.02	0.867	68.5

DC Axial Fan

Ø220x60mm

- Housing: Aluminum
- Impeller: Plastic
- Bearing: Ball Type
- Certification: CE, RoHS
- Additional functions are optional



Model	Voltage	Current	Power	Speed	Air Flow		Pressure		Noise
	VDC	Amp	Watt	RPM	CFM	m3/min	mmH2O	inH2O	dB(A)
AXD22060V24LR-K	24	0.78	18.82	2000	400.58	11.38	6.65	0.262	54.6
AXD22060V24L-K	24	1.39	33.36	2500	513.39	14.585	12.15	0.478	60
AXD22060V24M-K	24	2.25	54	3000	586.69	16.673	17.28	0.68	63.6
AXD22060V24H-K	24	3.52	84.38	3500	645.61	18.341	22.02	0.867	68.5

DC Axial Fan

Ø220x60mm

- Housing: Aluminum
- Impeller: Plastic
- Bearing: Ball Type
- Certification: CE, RoHS
- Additional functions are optional



Model	Voltage	Current	Power	Speed	Air Flow		Pressure		Noise
	VDC	Amp	Watt	RPM	CFM	m3/min	mmH2O	inH2O	dB(A)
AXD22060V48LR-K	48	0.37	17.86	2000	400.58	11.38	6.65	0.262	54.6
AXD22060V48L-K	48	0.66	31.68	2500	513.39	14.585	12.15	0.478	60
AXD22060V48M-K	48	1.07	51.36	3000	586.69	16.673	17.28	0.68	63.6
AXD22060V48H-K	48	1.67	80.16	3500	645.61	18.341	22.02	0.867	68.5

DC Axial Fan

Ø220x60mm

- Dimension:

Unit: mm

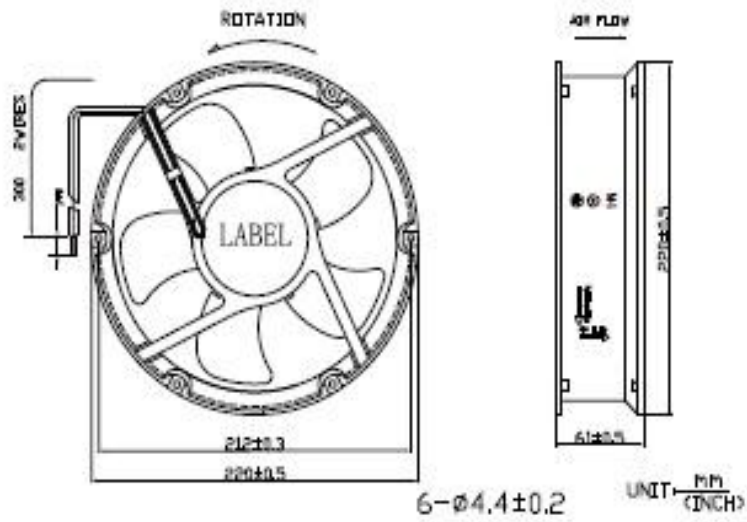

- Performance:

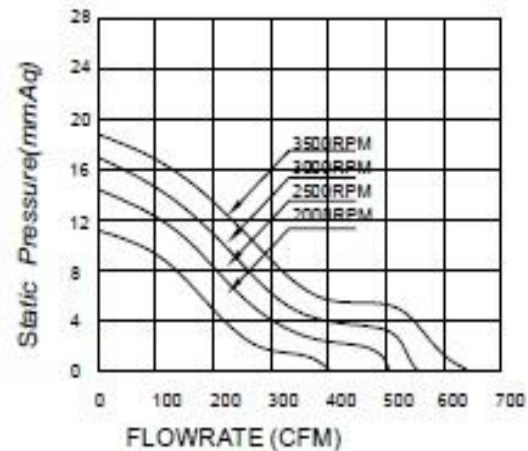

DC Axial Fan

Ø254x89mm

- Housing: Aluminum
- Impeller: Plastic
- Bearing: Ball Type
- Certification: CE, RoHS
- Additional functions are optional



Model	Voltage	Current	Power	Speed	Air Flow		Pressure		Noise
	VDC	Amp	Watt	RPM	CFM	m3/min	mmH2O	inH2O	dB(A)
AXD25489V12L-K	12	0.75	9	1000	305.30	8067	11.8	0.46	53.4
AXD25489V12M-K	12	3.5	42	2000	548.60	15.58	15.4	0.61	66.1
AXD25489V12H-K	12	5.5	66	2500	691.80	19.64	24.7	0.97	71.2

DC Axial Fan

Ø254x89mm

- Housing: Aluminum
- Impeller: Plastic
- Bearing: Ball Type
- Certification: CE, RoHS
- Additional functions are optional



Model	Voltage	Current	Power	Speed	Air Flow		Pressure		Noise
	VDC	Amp	Watt	RPM	CFM	m3/min	mmH2O	inH2O	dB(A)
AXD25489V24LW-K	24	0.5	12	1000	305.30	8067	11.8	0.46	53.4
AXD25489V24LR-K	24	1.5	36	2000	548.60	15.58	15.4	0.61	66.1
AXD25489V24L-K	24	2.9	69.6	2500	691.80	19.64	24.7	0.97	71.2
AXD25489V24M-K	24	3.7	88.8	3000	847.80	24.07	32.6	1.28	75.6
AXD25489V24H-K	24	5.7	136.8	3500	1035.60	29.4	38.6	1.52	80.4
AXD25489V24HR-K	24	7.8	187.2	4000	1296.40	36.81	42.1	1.66	89.6

DC Axial Fan

Ø254x89mm

- Housing: Aluminum
- Impeller: Plastic
- Bearing: Ball Type
- Certification: CE, RoHS
- Additional functions are optional



Model	Voltage	Current	Power	Speed	Air Flow		Pressure		Noise
	VDC	Amp	Watt	RPM	CFM	m3/min	mmH2O	inH2O	dB(A)
AXD25489V48LW-K	48	0.2	9.6	1000	305.30	8067	11.8	0.46	53.4
AXD25489V48LR-K	48	0.8	38.4	2000	548.60	15.58	15.4	0.61	66.1
AXD25489V48L-K	48	1.4	67.2	2500	691.80	19.64	24.7	0.97	71.2
AXD25489V48M-K	48	1.9	91.2	3000	847.80	24.07	32.6	1.28	75.6
AXD25489V48H-K	48	3	144	3500	1035.60	29.4	38.6	1.52	80.4
AXD25489V48HR-K	48	4	192	4000	1296.40	36.81	42.1	1.66	89.6

DC Axial Fan

Ø254x89mm

- Dimension:

Unit: mm

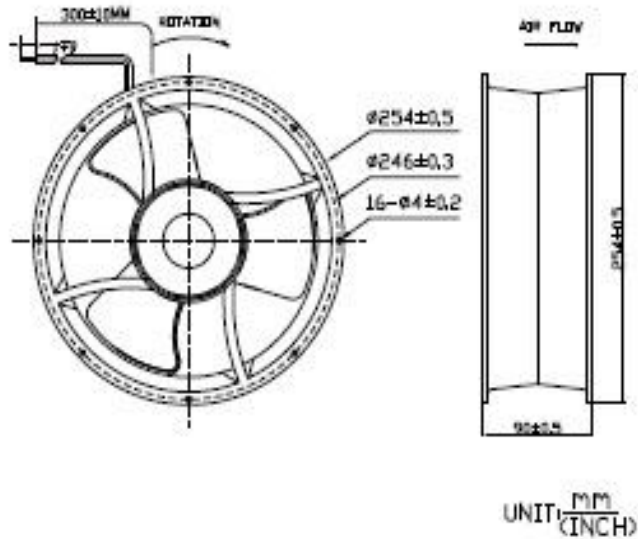

- Performance:

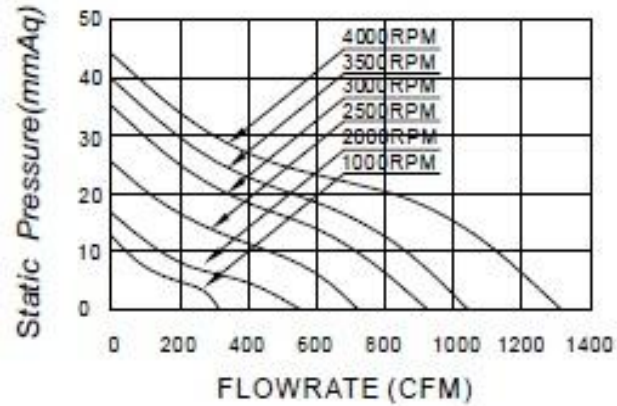

DC Axial Fan

Ø180x70mm

- Housing: Metal
- Impeller: Plastic
- Bearing: Ball Type
- Protection: IP44
- Certification: CE, RoHS
- Additional functions are optional



Model	Voltage	Current	Power	Speed	Air Flow		Pressure		Noise
	VDC	Amp	Watt	RPM	CFM	m3/h	inH2O	Pa	dB(A)
OXD18070V24H-M	24	4.2	100.8	4500	544.43	925	2.84	709	68
OXD18070V48H-M	48	2.1	100.8	4500	544.43	925	2.84	709	68

DC Axial Fan

Ø180x70mm

- Dimension:
Unit: mm

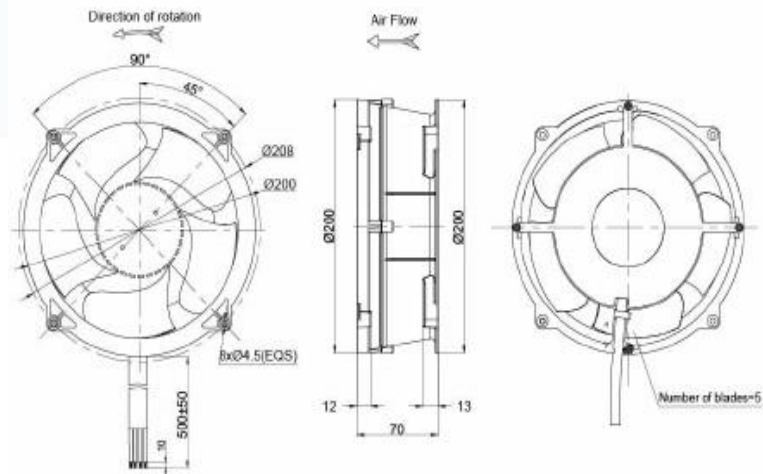

- Performance:

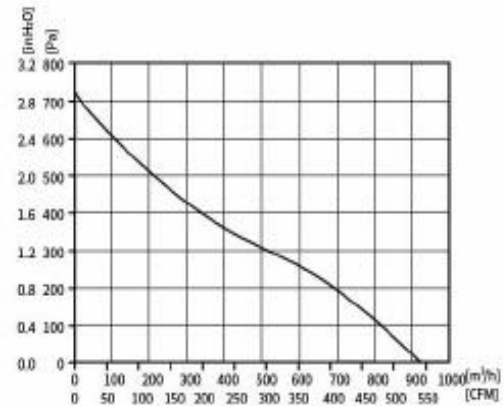

DC Axial Fan

Ø200x80mm

- Housing: Metal
- Impeller: Plastic
- Bearing: Ball Type
- Protection: IP44
- Certification: CE, RoHS
- Additional functions are optional



Model	Voltage	Current	Power	Speed	Air Flow		Pressure		Noise
	VDC	Amp	Watt	RPM	CFM	m3/h	inH2O	Pa	dB(A)
OXD20080V24H-M	24	1.8	43.2	2750	676.86	1150	0.94	236	60
OXD20080V48H-M	48	0.9	43.2	2750	676.86	1150	0.94	236	60

DC Axial Fan

Ø200x80mm

- Dimension:

Unit: mm

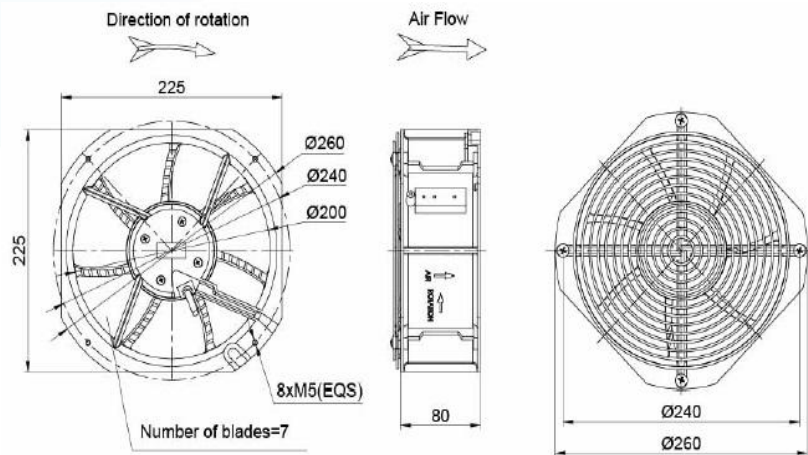

- Performance:

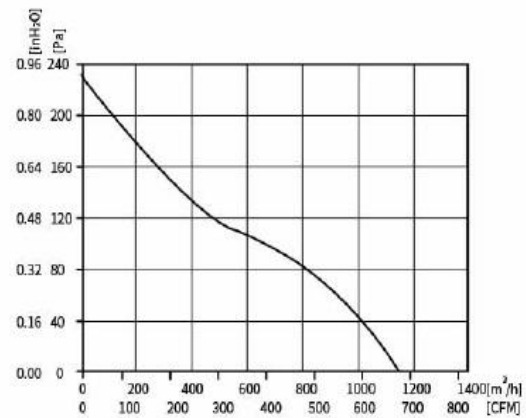

DC Axial Fan

Ø215x89mm

- Housing: Metal
- Impeller: Plastic
- Bearing: Ball Type
- Protection: IP44
- Certification: CE, RoHS
- Additional functions are optional



Model	Voltage	Current	Power	Speed	Air Flow		Pressure		Noise
	VDC	Amp	Watt	RPM	CFM	m3/h	inH2O	Pa	dB(A)
OXD21589V24H-M	24	1.9	91	3100	889.92	1512	1.18	294	69
OXD21589V48H-M	48	0.95	91	3100	889.92	1512	1.18	294	69

DC Axial Fan

Ø215x89mm

- Dimension:

Unit: mm

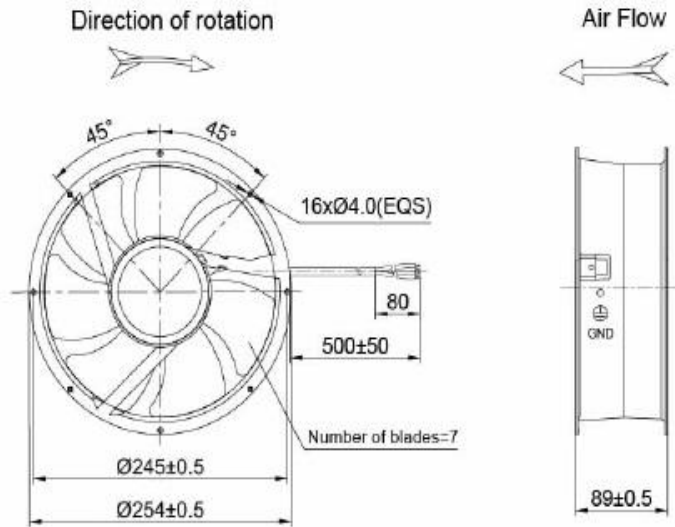

- Performance:

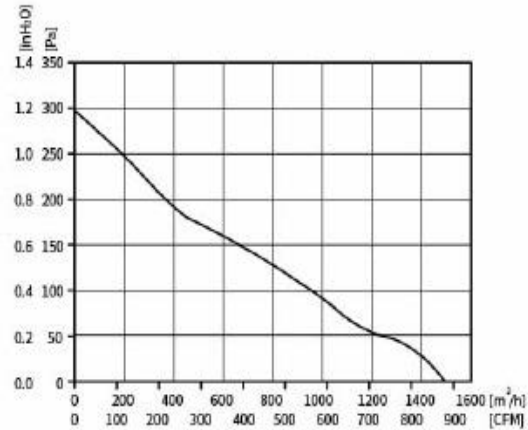

DC Axial Fan

Ø215x89mm - B Type

- Housing: Metal
- Impeller: Plastic
- Bearing: Ball Type
- Protection: IP44
- Certification: CE, RoHS
- Additional functions are optional



Model	Voltage	Current	Power	Speed	Air Flow		Pressure		Noise
	VDC	Amp	Watt	RPM	CFM	m3/h	inH2O	Pa	dB(A)
OXD21589V24M-M2	24	1.5	72	2500	829.89	1410	0.76	190	65
OXD21589V48M-M2	48	0.75	72	2500	829.89	1410	0.76	190	65

DC Axial Fan

Ø215x89mm - B Type

- Dimension:

Unit: mm

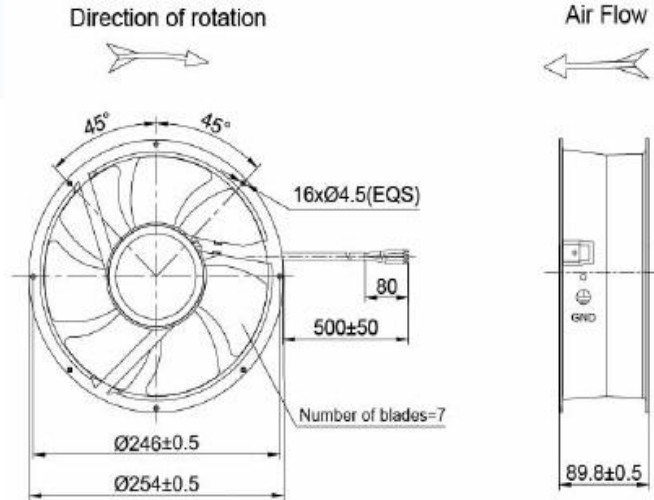

- Performance:

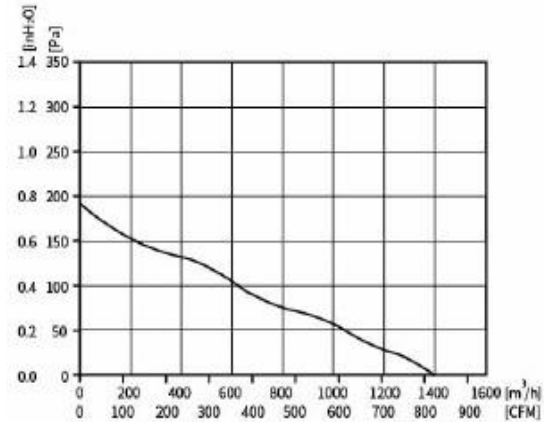

DC Axial Fan

Ø215x89mm - C Type

- Housing: Metal
- Impeller: Plastic
- Bearing: Ball Type
- Protection: IP44
- Certification: CE, RoHS
- Additional functions are optional



Model	Voltage	Current	Power	Speed	Air Flow		Pressure		Noise
	VDC	Amp	Watt	RPM	CFM	m3/h	inH2O	Pa	dB(A)
OXD21589V24L-M3	24	2.6	62.4	2000	723.95	1230	0.72	180	62
OXD21589V48L-M3	48	1.3	62.4	2000	723.95	1230	0.72	180	62

DC Axial Fan

Ø215x89mm - C Type

- Dimension:
Unit: mm

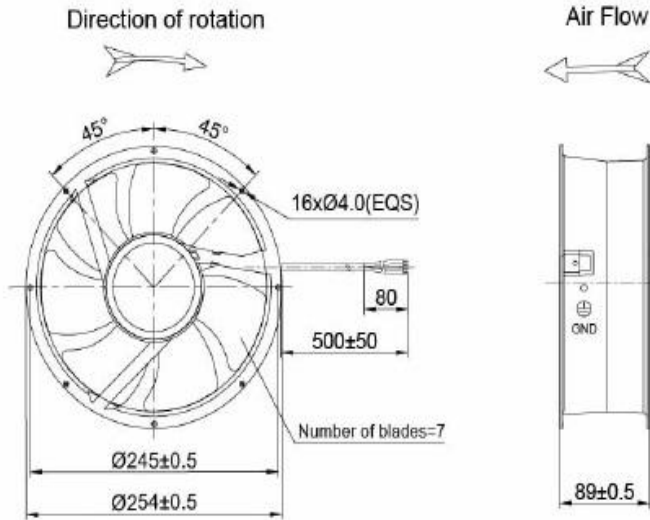

- Performance:

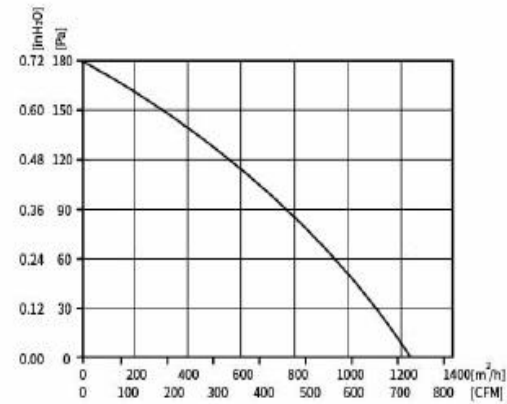

DC Axial Fan

Ø250x80mm

- Housing: Metal
- Impeller: Plastic
- Bearing: Ball Type
- Protection: IP44
- Certification: CE, RoHS
- Additional functions are optional



Model	Voltage	Current	Power	Speed	Air Flow		Pressure		Noise
	VDC	Amp	Watt	RPM	CFM	m3/h	inH2O	Pa	dB(A)
OXD25080V24H-M	24	4.8	115.2	2750	1118.29	1900	0.88	220	69
OXD25080V48H-M	48	2.4	115.2	2750	1118.29	1900	0.88	220	69

DC Axial Fan

Ø250x80mm

- Dimension:

Unit: mm

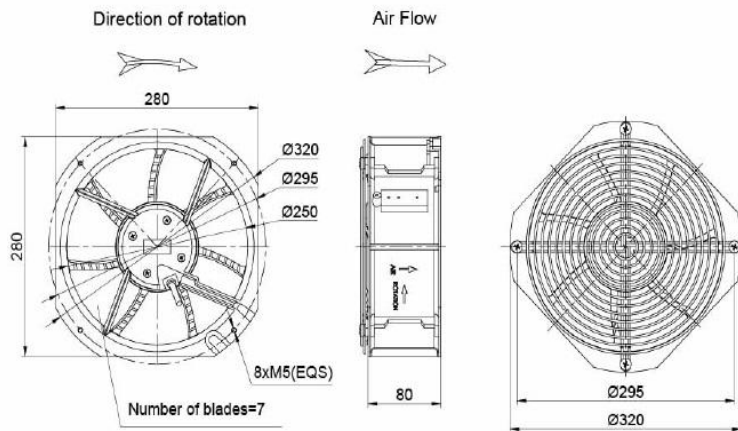

- Performance:

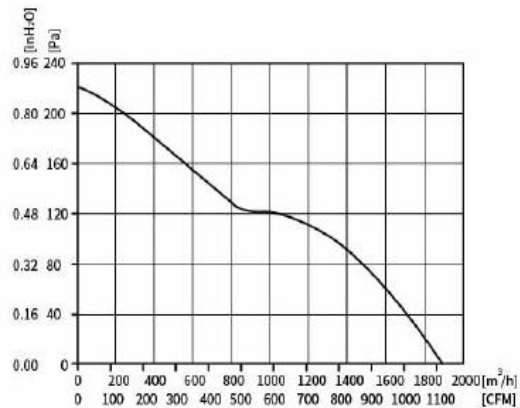

DC Axial Fan

Ø300x90mm

- Housing: Metal
- Impeller: Plastic
- Bearing: Ball Type
- Protection: IP44
- Certification: CE, RoHS
- Additional functions are optional



Model	Voltage	Current	Power	Speed	Air Flow		Pressure		Noise
	VDC	Amp	Watt	RPM	CFM	m3/h	inH2O	Pa	dB(A)
OXD30090V24H-M	24	6.5	156	2200	1371.38	2330	1.26	316	65
OXD30090V48H-M	48	3.25	156	2200	1371.38	2330	1.26	316	65

DC Axial Fan

Ø400x140mm

- Housing: Metal
- Impeller: Plastic
- Bearing: Ball Type
- Protection: IP44
- Certification: CE, RoHS
- Additional functions are optional



Model	Voltage	Current	Power	Speed	Air Flow		Pressure		Noise
	VDC	Amp	Watt	RPM	CFM	m3/h	inH2O	Pa	dB(A)
OXD400140V24L-M	24	6.4	153.6	1100	1979.38	3363	0.43	108	58
OXD400140V48L-M	48	3.2	153.6	1100	1979.38	3363	0.43	108	58

DC Axial Fan

Ø400x140mm

- Dimension:

Unit: mm

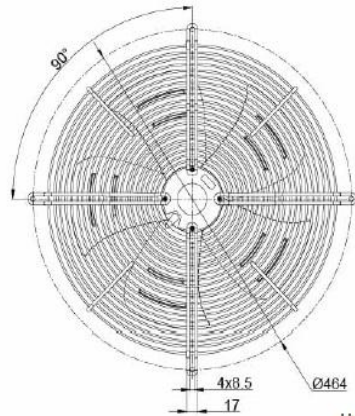
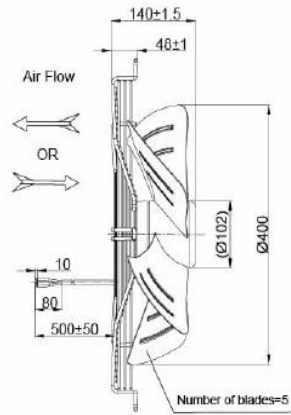

Unit: mm

- Performance:

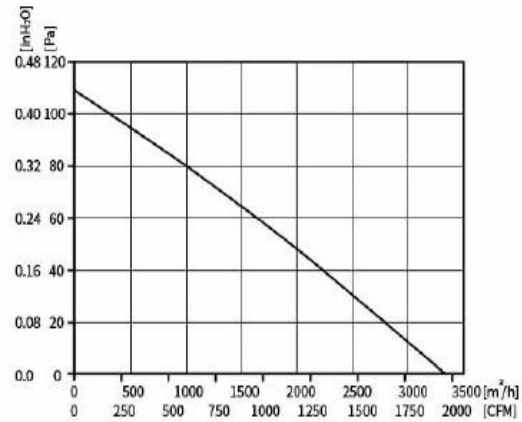

DC Axial Fan

Ø450x124mm

- Housing: Metal
- Impeller: Plastic
- Bearing: Ball Type
- Protection: IP44
- Certification: CE, RoHS
- Additional functions are optional



Model	Voltage	Current	Power	Speed	Air Flow		Pressure		Noise
	VDC	Amp	Watt	RPM	CFM	m3/h	inH2O	Pa	dB(A)
OXD450124V24L-M	24	6.6	160	1050	2825.17	4800	0.28	70	60
OXD450124V48L-M	48	3.3	160	1050	2825.17	4800	0.28	70	60

DC Axial Fan

Ø450x124mm

- Dimension:

Unit: mm

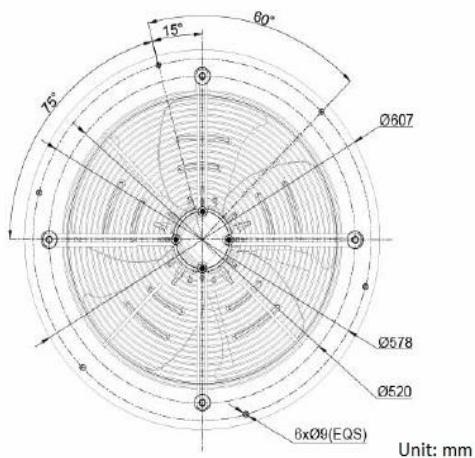
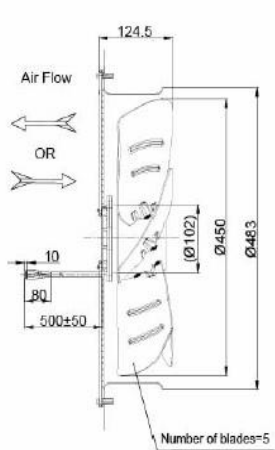

- Performance:

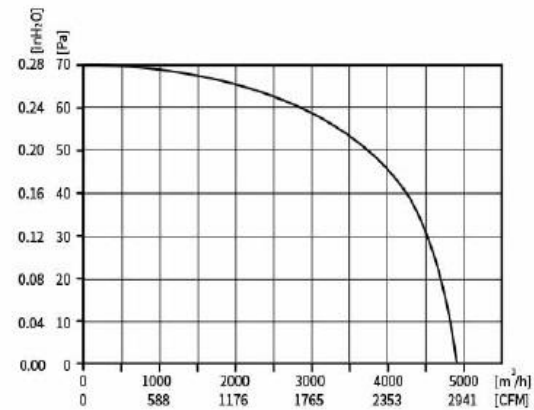

DC Axial Fan

40x40x10mm

- Impeller: Plastic
- Bearing: Ball, Sleeve
- Certification: CE, RoHS
- Additional functions are optional



Model	Voltage	Current	Power	Speed	Air Flow		Pressure		Noise
	VDC	Amp	Watt	RPM	CFM	m3/min	mmH2O	inH2o	dB(A)
FXD4010V5L-N	5	0.07	0.35	3000	1.90	0.05	1.92	0.08	18
FXD4010V5M-N	5	0.15	0.75	4000	2.53	0.07	2.56	0.1	22
FXD4010V5H-N	5	0.25	1.25	5000	3.16	0.09	3.2	0.13	27
FXD4010V5HR-N	5	0.45	2.25	6000	3.80	0.11	3.84	0.15	31

DC Axial Fan

40x40x10mm

- Impeller: Plastic
- Bearing: Ball, Sleeve
- Certification: CE, RoHS
- Additional functions are optional



Model	Voltage	Current	Power	Speed	Air Flow		Pressure		Noise
	VDC	Amp	Watt	RPM	CFM	m3/min	mmH2O	inH2o	dB(A)
FXD4010V12L-N	12	0.03	0.36	3000	1.90	0.05	1.92	0.08	18
FXD4010V12M-N	12	0.06	0.72	4000	2.53	0.07	2.56	0.1	22
FXD4010V12H-N	12	0.1	1.2	5000	3.16	0.09	3.2	0.13	27
FXD4010V12HR-N	12	0.18	2.16	6000	3.80	0.11	3.84	0.15	31

DC Axial Fan

40x40x10mm

- Impeller: Plastic
- Bearing: Ball, Sleeve
- Certification: CE, RoHS
- Additional functions are optional



Model	Voltage	Current	Power	Speed	Air Flow		Pressure		Noise
	VDC	Amp	Watt	RPM	CFM	m3/min	mmH2O	inH2o	dB(A)
FXD4010V24L-N	24	0.02	0.48	3000	1.90	0.05	1.92	0.08	18
FXD4010V24M-N	24	0.03	0.72	4000	2.53	0.07	2.56	0.1	22
FXD4010V24H-N	24	0.05	1.2	5000	3.16	0.09	3.2	0.13	27
FXD4010V24HR-N	24	0.09	2.16	6000	3.80	0.11	3.84	0.15	31

DC Axial Fan

40x40x10mm

- Dimension:

Unit: mm

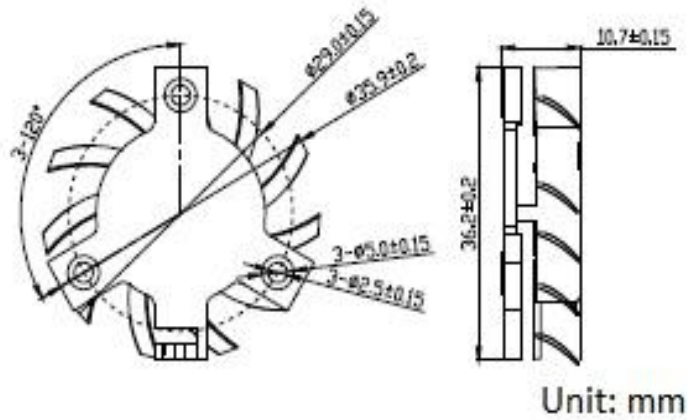

- Performance:

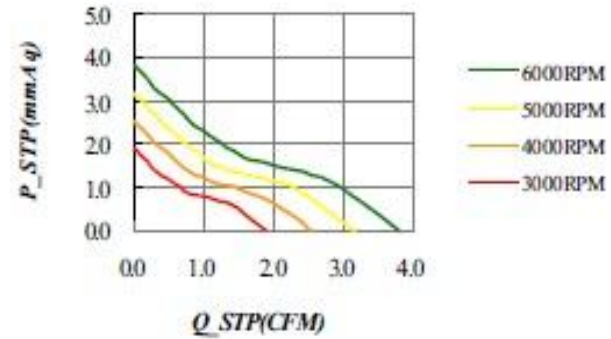

DC Axial Fan

50x50x10mm - C Type

- Impeller: Thermoplastic PBT (UL94V-0)
- Bearing: Ball, Sleeve
- Certification: CE, RoHS
- Additional functions are optional



Model	Voltage	Current	Power	Speed	Air Flow		Pressure		Noise
	VDC	Amp	Watt	RPM	CFM	m3/min	mmH2O	inH2o	dB(A)
FXD5010V5L-N3	5	0.12	0.6	4000	6.45	0.18	1.96	0.08	27
FXD5010V5M-N3	5	0.22	1.1	5000	8.97	0.25	2.84	0.11	30.5
FXD5010V12L-N3	12	0.05	0.6	4000	6.45	0.18	1.96	0.08	27
FXD5010V12M-N3	12	0.09	1.08	5000	8.97	0.25	2.84	0.11	30.5
FXD5010V12H-N3	12	0.15	1.8	6000	11.77	0.33	3.85	0.15	33.8
FXD5010V12HR-N3	12	0.25	3	6500	14.13	0.4	4.7	0.19	35.5

DC Axial Fan

50x50x10mm - C Type

- Impeller: Thermoplastic PBT (UL94V-0)
- Bearing: Ball, Sleeve
- Certification: CE, RoHS
- Additional functions are optional



Model	Voltage	Current	Power	Speed	Air Flow		Pressure		Noise
	VDC	Amp	Watt	RPM	CFM	m3/min	mmH2O	inH2o	dB(A)
FXD5010V24L-N3	24	0.03	0.72	4000	6.45	0.18	1.96	0.08	27
FXD5010V24M-N3	24	0.05	1.2	5000	8.97	0.25	2.84	0.11	30.5
FXD5010V24H-N3	24	0.08	1.92	6000	11.77	0.33	3.85	0.15	33.8
FXD5010V24HR-N3	24	0.13	3.12	6500	14.13	0.4	4.7	0.19	35.5

DC Axial Fan

50x50x10mm - C Type

- Dimension:

Unit: mm

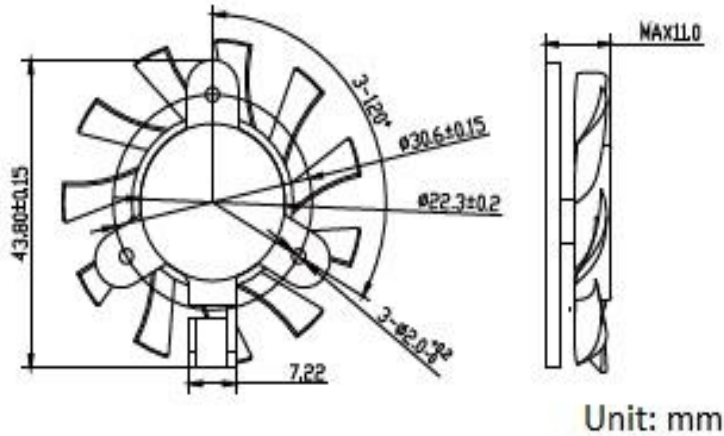

- Performance:

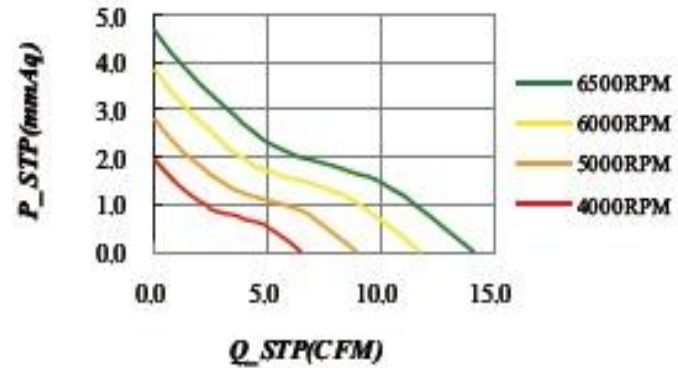

DC Axial Fan

50x50x10mm - D Type

- Impeller: Thermoplastic PBT (UL94V-0)
- Bearing: Ball, Sleeve
- Certification: CE, RoHS
- Additional functions are optional



Model	Voltage	Current	Power	Speed	Air Flow		Pressure		Noise
	VDC	Amp	Watt	RPM	CFM	m3/min	mmH2O	inH2o	dB(A)
FXD5010V5L-N4	5	0.15	0.75	4000	8.60	0.24	2.97	0.12	27
FXD5010V5M-N4	5	0.2	1	5000	11.45	0.32	3.33	0.13	32
FXD5010V12L-N4	12	0.06	0.72	4000	8.60	0.24	2.97	0.12	27
FXD5010V12M-N4	12	0.08	0.96	5000	11.45	0.32	3.33	0.13	32
FXD5010V12H-N4	12	0.14	1.68	6000	11.93	0.34	4.5	0.18	36
FXD5010V12HR-N4	12	0.2	2.4	6500	14.23	0.4	5.01	0.2	37.5

DC Axial Fan

50x50x10mm - D Type

- Impeller: Thermoplastic PBT (UL94V-0)
- Bearing: Ball, Sleeve
- Certification: CE, RoHS
- Additional functions are optional



Model	Voltage	Current	Power	Speed	Air Flow		Pressure		Noise
	VDC	Amp	Watt	RPM	CFM	m3/min	mmH2O	inH2o	dB(A)
FXD5010V24L-N4	24	0.03	0.72	4000	8.60	0.24	2.97	0.12	27
FXD5010V24M-N4	24	0.04	0.96	5000	11.45	0.32	3.33	0.13	32
FXD5010V24H-N4	24	0.07	1.68	6000	11.93	0.34	4.5	0.18	36
FXD5010V24HR-N4	24	0.1	2.4	6500	14.23	0.4	5.01	0.2	37.5

DC Axial Fan

50x50x10mm - D Type

- Dimension:

Unit: mm

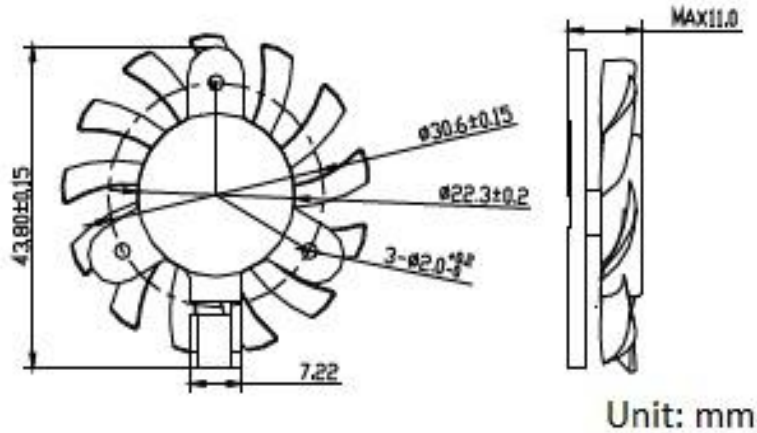

- Performance:

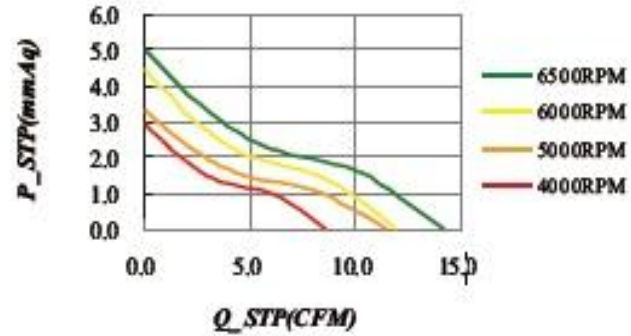

DC Axial Fan

60x60x10mm

- Impeller: Thermoplastic PBT (UL94V-0)
- Bearing: Ball, Sleeve
- Certification: CE, RoHS
- Additional functions are optional



Model	Voltage	Current	Power	Speed	Air Flow		Pressure		Noise
	VDC	Amp	Watt	RPM	CFM	m3/min	mmH2O	inH2o	dB(A)
FXD6010V5L-N	5	0.15	0.75	3000	10.74	0.31	2.64	0.1	21.6
FXD6010V5M-N	5	0.39	1.95	4000	14.32	0.41	3.52	0.14	28.8
FXD6010V12L-N	12	0.06	0.72	3000	10.74	0.31	2.64	0.1	21.6
FXD6010V12M-N	12	0.15	1.8	4000	14.32	0.41	3.52	0.14	28.8
FXD6010V12H-N	12	0.25	3	4500	16.11	0.46	3.97	0.16	30.8
FXD6010V12HR-N	12	0.37	4.44	5000	17.89	0.51	4.41	0.17	33.1

DC Axial Fan

60x60x10mm

- Impeller: Thermoplastic PBT (UL94V-0)
- Bearing: Ball, Sleeve
- Certification: CE, RoHS
- Additional functions are optional



Model	Voltage	Current	Power	Speed	Air Flow		Pressure		Noise
	VDC	Amp	Watt	RPM	CFM	m3/min	mmH2O	inH2o	dB(A)
FXD6010V24L-N	24	0.03	0.72	3000	10.74	0.31	2.64	0.1	21.6
FXD6010V24M-N	24	0.07	1.78	4000	14.32	0.41	3.52	0.14	28.8
FXD6010V24H-N	24	0.12	2.88	4500	16.11	0.46	3.97	0.16	30.8
FXD6010V24HR-N	24	0.18	4.22	5000	17.89	0.51	4.41	0.17	33.1

DC Axial Fan

60x60x10mm

- Dimension:

Unit: mm

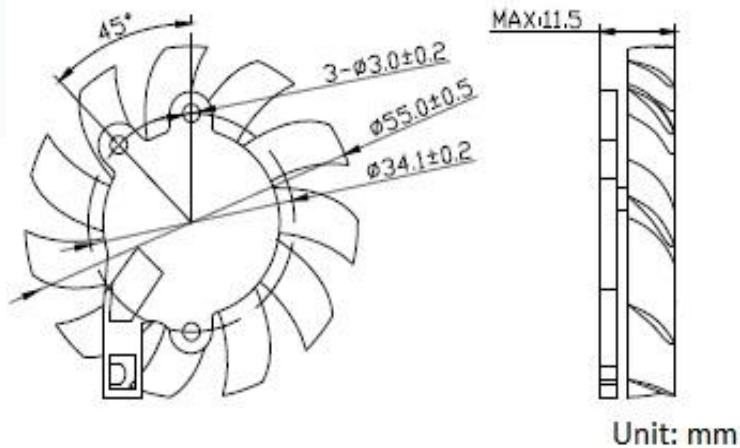

- Performance:

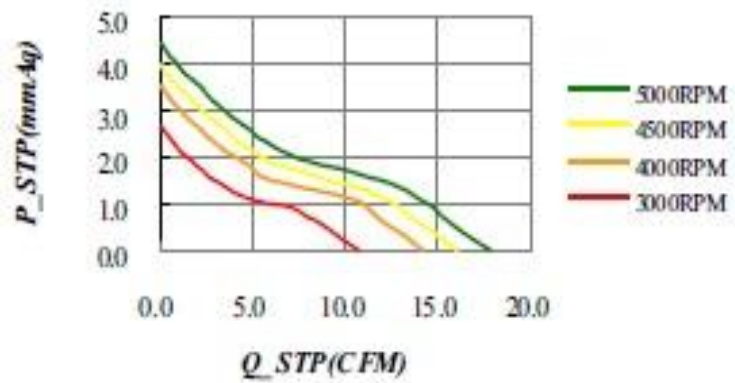

DC Axial Fan

60x60x15mm

- Impeller: Thermoplastic PBT (UL94V-0)
- Bearing: Ball, Sleeve
- Certification: CE, RoHS
- Additional functions are optional



Model	Voltage	Current	Power	Speed	Air Flow		Pressure		Noise
	VDC	Amp	Watt	RPM	CFM	m3/min	mmH2O	inH2o	dB(A)
FXD6010V5L-N	5	0.18	0.9	2000	4.64	0.13	0.38	0.015	22.5
FXD6010V5M-N	5	0.23	1.15	2500	5.79	0.16	0.59	0.023	27.4
FXD6015V5H-N	5	0.4	2	3000	6.95	0.2	0.85	0.033	31.3
FXD6010V12L-N	12	0.1	1.2	2000	4.64	0.13	0.38	0.015	22.5
FXD6010V12M-N	12	0.11	1.32	2500	5.79	0.16	0.59	0.023	27.4
FXD6010V12H-N	12	0.2	2.4	3000	6.95	0.2	0.85	0.033	31.3

DC Axial Fan

60x60x15mm

- Impeller: Thermoplastic PBT (UL94V-0)
- Bearing: Ball, Sleeve
- Certification: CE, RoHS
- Additional functions are optional



Model	Voltage	Current	Power	Speed	Air Flow		Pressure		Noise
	VDC	Amp	Watt	RPM	CFM	m3/min	mmH2O	inH2o	dB(A)
FXD6010V24L-N	24	0.05	1.2	2000	4.64	0.13	0.38	0.015	22.5
FXD6010V24M-N	24	0.05	1.2	2500	5.79	0.16	0.59	0.023	27.4
FXD6010V24H-N	24	0.09	2.16	3000	6.95	0.2	0.85	0.033	31.3

DC Axial Fan

60x60x15mm

- Dimension:

Unit: mm

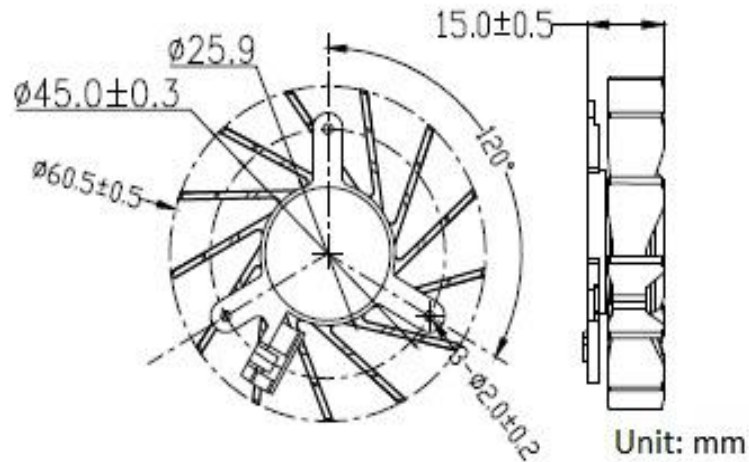

- Performance:

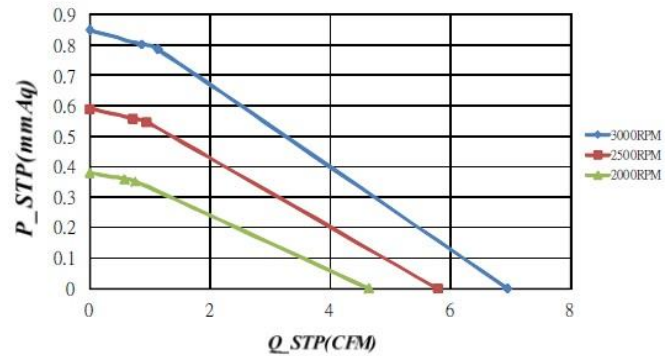

DC Axial Fan

60x60x25mm

- Impeller: Thermoplastic PBT (UL94V-0)
- Bearing: Ball Type
- Certification: CE, RoHS
- Additional functions are optional



Model	Voltage	Current	Power	Speed	Air Flow		Pressure		Noise
	VDC	Amp	Watt	RPM	CFM	m3/min	mmH2O	inH2o	dB(A)
FXD6025V5L-N	5	0.16	0.8	3000	15.36	0.44	5.72	0.23	26.5
FXD6025V5M-N	5	0.34	1.7	4000	20.48	0.58	7.63	0.3	33.2
FXD6025V5H-N	5	0.7	3.5	5000	25.60	0.73	9.53	0.38	38.4
FXD6025V5HR-N	5	1.22	6.1	6000	30.72	0.87	11.44	0.45	40.3
FXD6025V12L-N	12	0.06	0.72	3000	15.36	0.44	5.72	0.23	26.5
FXD6025V12M-N	12	0.14	1.68	4000	20.48	0.58	7.63	0.3	33.2
FXD6025V12H-N	12	0.28	3.36	5000	25.60	0.73	9.53	0.38	38.4
FXD6025V12HR-N	12	0.48	5.6	6000	30.72	0.87	11.44	0.45	40.3

DC Axial Fan

60x60x25mm

- Impeller: Thermoplastic PBT (UL94V-0)
- Bearing: Ball Type
- Certification: CE, RoHS
- Additional functions are optional



Model	Voltage	Current	Power	Speed	Air Flow		Pressure		Noise
	VDC	Amp	Watt	RPM	CFM	m3/min	mmH2O	inH2o	dB(A)
FXD6025V24L-N	24	0.03	0.72	3000	15.36	0.44	5.72	0.23	26.5
FXD6025V24M-N	24	0.06	1.54	4000	20.48	0.58	7.63	0.3	33.2
FXD6025V24H-N	24	0.14	3.36	5000	25.60	0.73	9.53	0.38	38.4
FXD6025V24HR-N	24	0.25	6	6000	30.72	0.87	11.44	0.45	40.3

DC Axial Fan

60x60x25mm

- Dimension:

Unit: mm

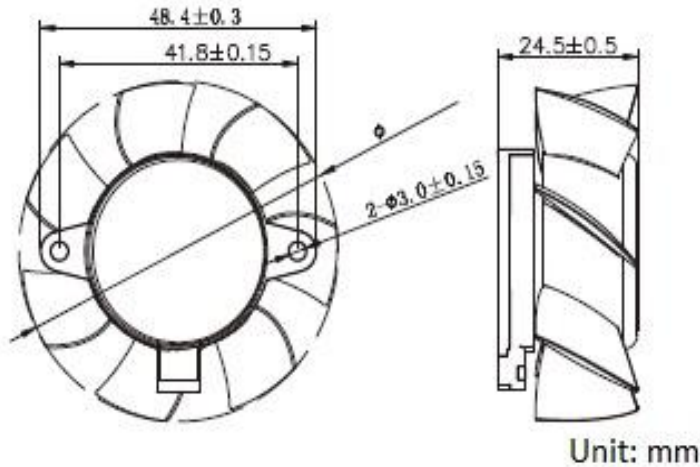

- Performance:

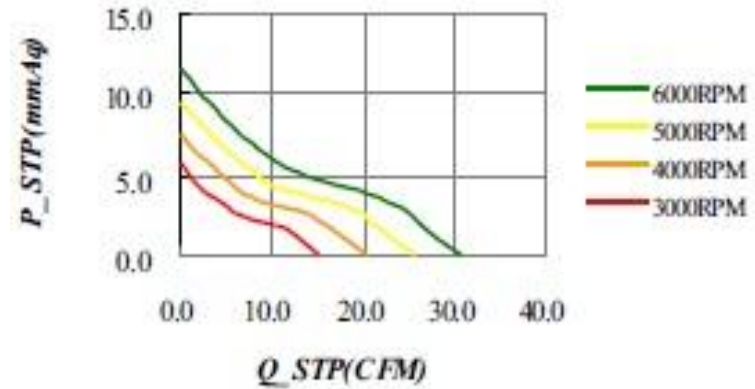

DC Axial Fan

70x70x10mm

- Impeller: Thermoplastic PBT (UL94V-0)
- Bearing: Ball Type
- Certification: CE, RoHS
- Additional functions are optional



Model	Voltage	Current	Power	Speed	Air Flow		Pressure		Noise
	VDC	Amp	Watt	RPM	CFM	m3/min	mmH2O	inH2o	dB(A)
FXD7010V5L-N	5	0.21	1.05	2000	10.31	0.29	0.9	0.03	23.4
FXD7010V5M-N	5	0.33	1.65	2500	14.71	0.42	1.55	0.06	27.2
FXD7010V5H-N	5	0.4	2	3000	18.46	0.52	2.07	0.08	30.9
FXD7010V12L-N	12	0.1	1.2	2000	10.31	0.29	0.9	0.03	23.4
FXD7010V12M-N	12	0.14	1.68	2500	14.71	0.42	1.55	0.06	27.2
FXD7010V12H-N	12	0.2	2.4	3000	18.46	0.52	2.07	0.08	30.9

DC Axial Fan

70x70x10mm

- Impeller: Thermoplastic PBT (UL94V-0)
- Bearing: Ball Type
- Certification: CE, RoHS
- Additional functions are optional



Model	Voltage	Current	Power	Speed	Air Flow		Pressure		Noise
	VDC	Amp	Watt	RPM	CFM	m3/min	mmH2O	inH2o	dB(A)
FXD7010V24L-N	24	0.05	1.2	2000	10.31	0.29	0.9	0.03	23.4
FXD7010V24M-N	24	0.07	1.68	2500	14.71	0.42	1.55	0.06	27.2
FXD7010V24H-N	24	0.1	2.4	3000	18.46	0.52	2.07	0.08	30.9

DC Axial Fan

70x70x10mm

- Dimension:

Unit: mm

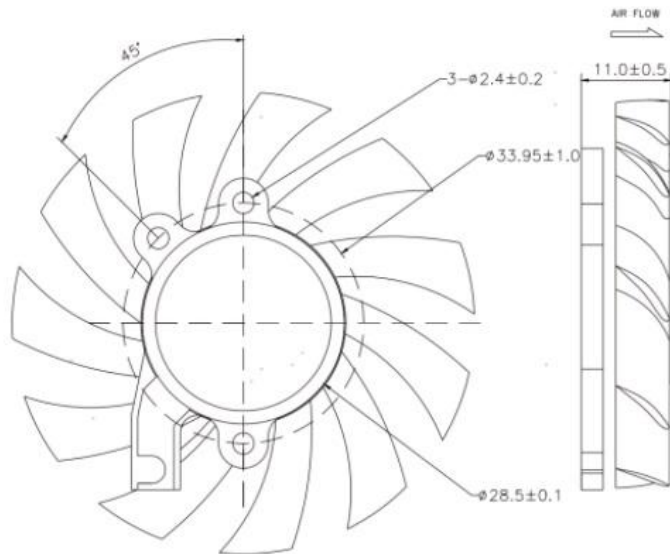

- Performance:

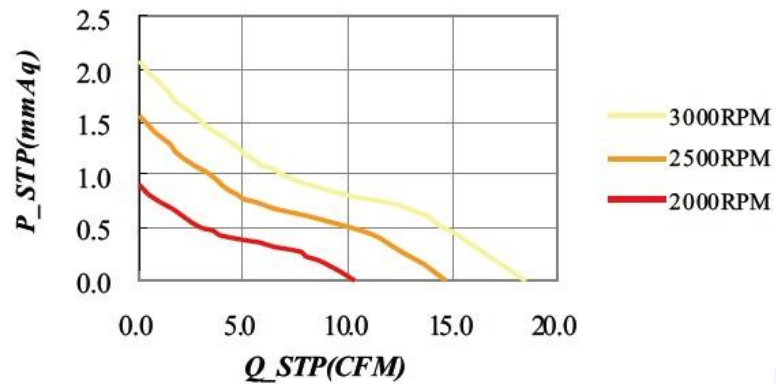

DC Axial Fan

80x80x15mm

- Impeller: Thermoplastic PBT (UL94V-0)
- Bearing: Ball Type
- Certification: CE, RoHS
- Additional functions are optional



Model	Voltage	Current	Power	Speed	Air Flow		Pressure		Noise
	VDC	Amp	Watt	RPM	CFM	m3/min	mmH2O	inH2o	dB(A)
FXD8015V5L-N	5	0.09	0.45	1500	14.64	0.42	1.43	0.06	19.8
FXD8015V5M-N	5	0.17	0.85	2000	19.53	0.55	1.91	0.08	24.6
FXD8015V5H-N	5	0.32	1.6	2500	24.41	0.69	2.39	0.09	28.7
FXD8015V5HR-N	5	0.7	3.5	3200	31.24	0.89	3.05	0.12	32.1

DC Axial Fan

80x80x15mm

- Impeller: Thermoplastic PBT (UL94V-0)
- Bearing: Ball Type
- Certification: CE, RoHS
- Additional functions are optional



Model	Voltage	Current	Power	Speed	Air Flow		Pressure		Noise
	VDC	Amp	Watt	RPM	CFM	m3/min	mmH2O	inH2o	dB(A)
FXD8015V12L-N	12	0.04	0.48	1500	14.64	0.42	1.43	0.06	19.8
FXD8015V12M-N	12	0.07	0.84	2000	19.53	0.55	1.91	0.08	24.6
FXD8015V12H-N	12	0.13	1.56	2500	24.41	0.69	2.39	0.09	28.7
FXD8015V12HR-N	12	0.28	3.36	3200	31.24	0.89	3.05	0.12	32.1

DC Axial Fan

80x80x15mm

- Impeller: Thermoplastic PBT (UL94V-0)
- Bearing: Ball Type
- Certification: CE, RoHS
- Additional functions are optional



Model	Voltage	Current	Power	Speed	Air Flow		Pressure		Noise
	VDC	Amp	Watt	RPM	CFM	m3/min	mmH2O	inH2o	dB(A)
FXD8015V24L-N	24	0.02	0.48	1500	14.64	0.42	1.43	0.06	19.8
FXD8015V24M-N	24	0.03	0.76	2000	19.53	0.55	1.91	0.08	24.6
FXD8015V24H-N	24	0.06	1.44	2500	24.41	0.69	2.39	0.09	28.7
FXD8015V24HR-N	24	0.13	3.12	3200	31.24	0.89	3.05	0.12	32.1

DC Axial Fan

80x80x15mm

- Dimension:

Unit: mm

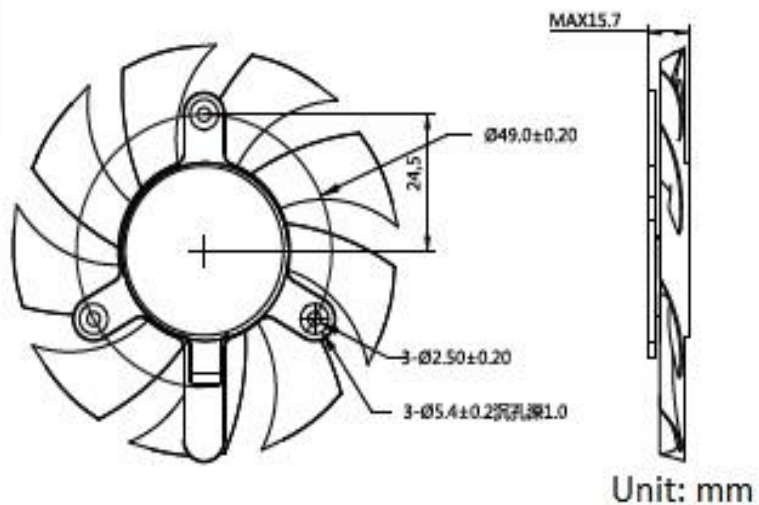

- Performance:

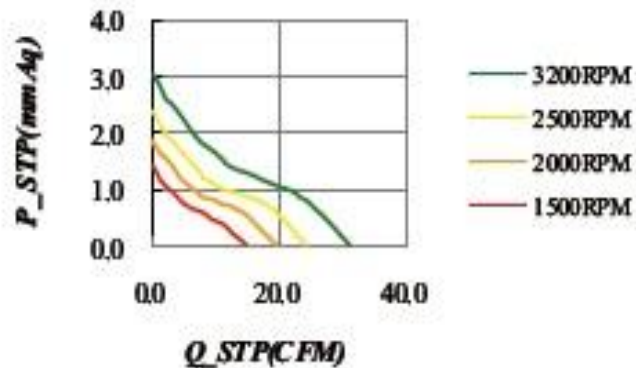

DC Axial Fan

80x80x25mm

- Impeller: Thermoplastic PBT (UL94V-0)
- Bearing: Ball Type
- Certification: CE, RoHS
- Additional functions are optional



Model	Voltage	Current	Power	Speed	Air Flow		Pressure		Noise
	VDC	Amp	Watt	RPM	CFM	m3/min	mmH2O	inH2o	dB(A)
FXD8025V5LW-N	5	0.13	0.65	2000	23.48	0.67	3.78	0.15	25.2
FXD8025V5LR-N	5	0.21	1.05	2500	29.35	0.83	4.72	0.19	28.3
FXD8025V5L-N	5	0.35	1.75	3000	35.22	1	5.67	0.22	35.2
FXD8025V5M-N	5	0.57	2.85	3500	41.09	1.17	6.61	0.26	37.6
FXD8025V5H-N	5	0.92	4.6	4000	46.96	1.33	7.55	0.3	42.9
FXD8025V5HR-N	5	1.39	6.95	4500	52.83	1.5	8.5	0.34	49.1

DC Axial Fan

80x80x25mm

- Impeller: Thermoplastic PBT (UL94V-0)
- Bearing: Ball Type
- Certification: CE, RoHS
- Additional functions are optional



Model	Voltage	Current	Power	Speed	Air Flow		Pressure		Noise
	VDC	Amp	Watt	RPM	CFM	m3/min	mmH2O	inH2o	dB(A)
FXD8025V12LW-N	12	0.05	0.6	2000	23.48	0.67	3.78	0.15	25.2
FXD8025V12LR-N	12	0.08	1.06	2500	29.35	0.83	4.72	0.19	28.3
FXD8025V12L-N	12	0.14	1.68	3000	35.22	1	5.67	0.22	35.2
FXD8025V12M-N	12	0.23	2.76	3500	41.09	1.17	6.61	0.26	37.6
FXD8025V12H-N	12	0.36	4.32	4000	46.96	1.33	7.55	0.3	42.9
FXD8025V12HR-N	12	0.55	6.6	4500	52.83	1.5	8.5	0.34	49.1

DC Axial Fan

80x80x25mm

- Impeller: Thermoplastic PBT (UL94V-0)
- Bearing: Ball Type
- Certification: CE, RoHS
- Additional functions are optional



Model	Voltage	Current	Power	Speed	Air Flow		Pressure		Noise
	VDC	Amp	Watt	RPM	CFM	m3/min	mmH2O	inH2o	dB(A)
FXD8025V24LW-N	24	0.02	0.48	2000	23.48	0.67	3.78	0.15	25.2
FXD8025V24LR-N	24	0.04	0.96	2500	29.35	0.83	4.72	0.19	28.3
FXD8025V24L-N	24	0.07	1.58	3000	35.22	1	5.67	0.22	35.2
FXD8025V24M-N	24	0.11	2.54	3500	41.09	1.17	6.61	0.26	37.6
FXD8025V24H-N	24	0.17	4.18	4000	46.96	1.33	7.55	0.3	42.9
FXD8025V24HR-N	24	0.26	6.24	4500	52.83	1.5	8.5	0.34	49.1

DC Axial Fan

80x80x25mm

- Dimension:

Unit: mm

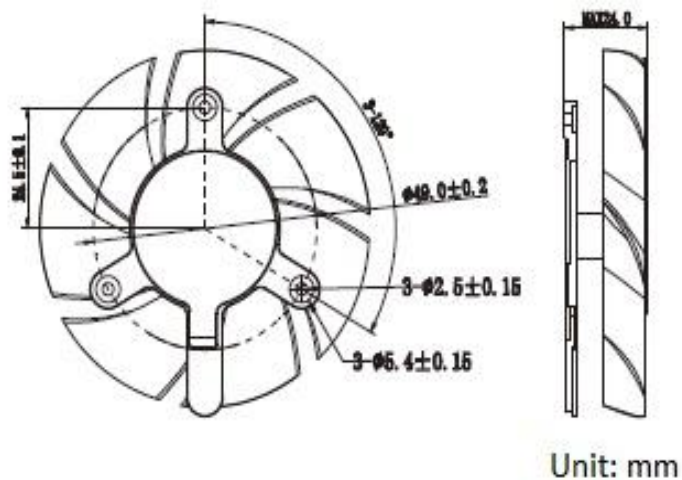

- Performance:

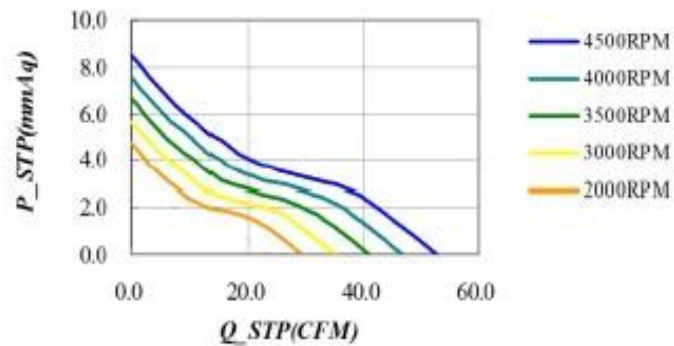

DC Axial Fan

90x90x10mm

- Impeller: Thermoplastic PBT (UL94V-0)
- Bearing: Ball Type
- Certification: CE, RoHS
- Additional functions are optional



Model	Voltage	Current	Power	Speed	Air Flow		Pressure		Noise
	VDC	Amp	Watt	RPM	CFM	m3/min	mmH2O	inH2o	dB(A)
FXD9010V5LR-N	5	0.08	0.4	1500	15.65	0.44	1.25	0.05	22.3
FXD9010V5L-N	5	0.16	0.8	2000	20.75	0.59	1.63	0.06	25.8
FXD9010V5M-N	5	0.26	1.3	2500	25.94	0.73	2.03	0.08	30.6
FXD9010V5H-N	5	0.38	1.9	3000	31.32	0.89	2.45	0.1	33.9

DC Axial Fan

90x90x10mm

- Impeller: Thermoplastic PBT (UL94V-0)
- Bearing: Ball Type
- Certification: CE, RoHS
- Additional functions are optional



Model	Voltage	Current	Power	Speed	Air Flow		Pressure		Noise
	VDC	Amp	Watt	RPM	CFM	m3/min	mmH2O	inH2o	dB(A)
FXD9010V12LR-N	12	0.03	0.36	1500	15.65	0.44	1.25	0.05	22.3
FXD9010V12L-N	12	0.07	0.84	2000	20.75	0.59	1.63	0.06	25.8
FXD9010V12M-N	12	0.11	1.32	2500	25.94	0.73	2.03	0.08	30.6
FXD9010V12H-N	12	0.16	1.92	3000	31.32	0.89	2.45	0.1	33.9
FXD9010V12HR-N	12	0.32	3.84	3500	36.21	1.02	2.86	0.11	37.8

DC Axial Fan

90x90x10mm

- Impeller: Thermoplastic PBT (UL94V-0)
- Bearing: Ball Type
- Certification: CE, RoHS
- Additional functions are optional



Model	Voltage	Current	Power	Speed	Air Flow		Pressure		Noise
	VDC	Amp	Watt	RPM	CFM	m3/min	mmH2O	inH2o	dB(A)
FXD9010V24LR-N	24	0.02	0.48	1500	15.65	0.44	1.25	0.05	22.3
FXD9010V24L-N	24	0.03	0.72	2000	20.75	0.59	1.63	0.06	25.8
FXD9010V24M-N	24	0.05	1.2	2500	25.94	0.73	2.03	0.08	30.6
FXD9010V24H-N	24	0.08	1.92	3000	31.32	0.89	2.45	0.1	33.9
FXD9010V24HR-N	24	0.15	3.6	3500	36.21	1.02	2.86	0.11	37.8

DC Axial Fan

90x90x10mm

- Dimension:

Unit: mm

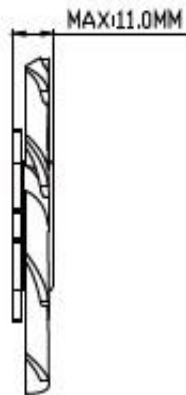
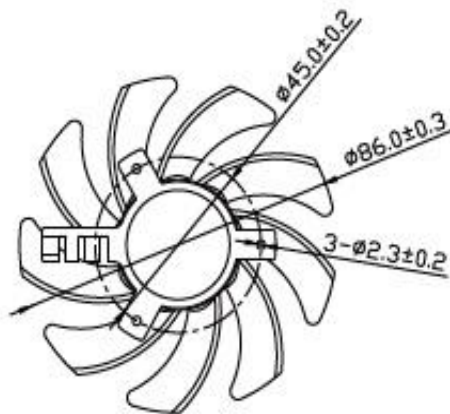

Unit: mm

- Performance:

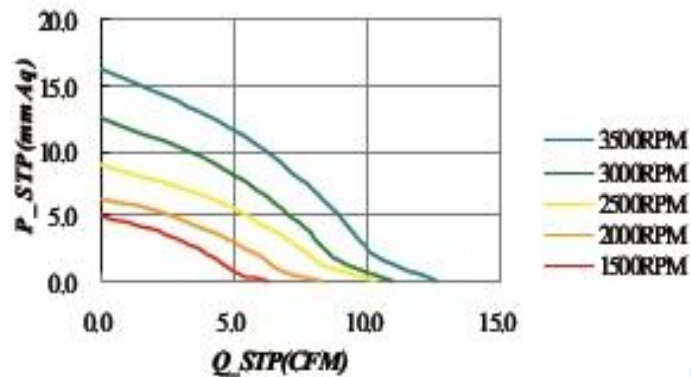

DC Axial Fan

90x90x17mm

- Impeller: Thermoplastic PBT (UL94V-0)
- Bearing: Ball Type
- Certification: CE, RoHS
- Additional functions are optional



Model	Voltage	Current	Power	Speed	Air Flow		Pressure		Noise
	VDC	Amp	Watt	RPM	CFM	m3/min	mmH2O	inH2o	dB(A)
FXD9017V5LR-N	5	0.08	0.4	1500	22.87	0.65	3.07	0.12	22.3
FXD9017V5L-N	5	0.18	0.9	2000	30.49	0.87	4.09	0.16	25.8
FXD9017V5M-N	5	0.35	1.75	2500	38.11	1.08	5.11	0.2	30.6

DC Axial Fan

90x90x17mm

- Impeller: Thermoplastic PBT (UL94V-0)
- Bearing: Ball Type
- Certification: CE, RoHS
- Additional functions are optional



Model	Voltage	Current	Power	Speed	Air Flow		Pressure		Noise
	VDC	Amp	Watt	RPM	CFM	m3/min	mmH2O	inH2o	dB(A)
FXD9017V12LR-N	12	0.03	0.36	1500	22.87	0.65	3.07	0.12	22.3
FXD9017V12L-N	12	0.07	0.84	2000	30.49	0.87	4.09	0.16	25.8
FXD9017V12M-N	12	0.14	1.68	2500	38.11	1.08	5.11	0.2	30.6
FXD9017V12H-N	12	0.28	3.36	3000	45.73	1.3	6.13	0.24	33.9
FXD9017V12HR-N	12	0.47	5.54	3500	53.36	1.51	7.16	0.28	37.8

DC Axial Fan

90x90x17mm

- Impeller: Thermoplastic PBT (UL94V-0)
- Bearing: Ball Type
- Certification: CE, RoHS
- Additional functions are optional



Model	Voltage	Current	Power	Speed	Air Flow		Pressure		Noise
	VDC	Amp	Watt	RPM	CFM	m3/min	mmH2O	inH2o	dB(A)
FXD9017V24LR-N	24	0.02	0.48	1500	22.87	0.65	3.07	0.12	22.3
FXD9017V24L-N	24	0.03	0.82	2000	30.49	0.87	4.09	0.16	25.8
FXD9017V24M-N	24	0.07	1.58	2500	38.11	1.08	5.11	0.2	30.6
FXD9017V24H-N	24	0.13	3.12	3000	45.73	1.3	6.13	0.24	33.9
FXD9017V24HR-N	24	0.22	5.38	3500	53.36	1.51	7.16	0.28	37.8

DC Axial Fan

90x90x17mm

- Dimension:

Unit: mm

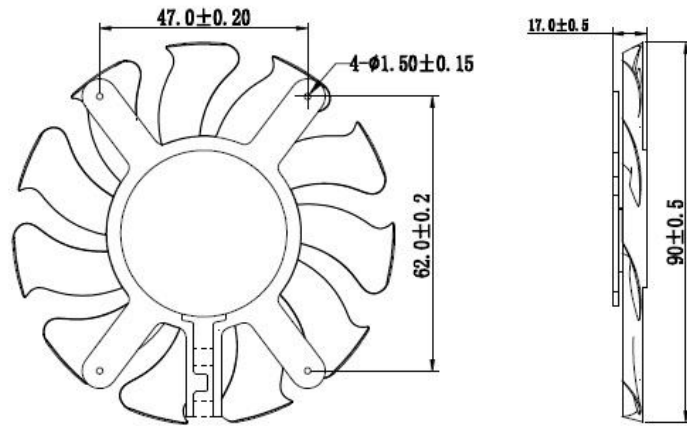

Unit: mm

- Performance:

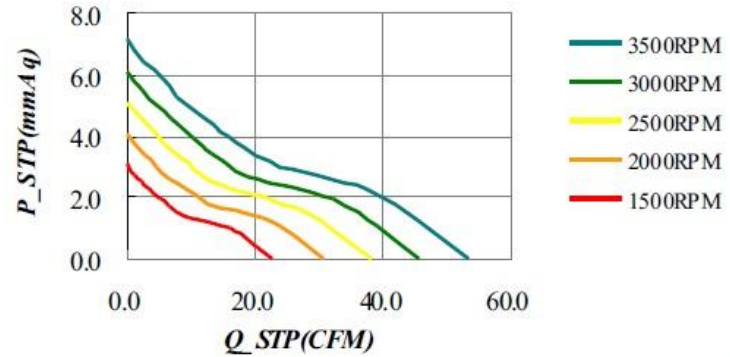



Change is a perpetual motion

Phone: +886-7-215-0001

Mobile: +886-938-016696

E-mail: service@cainton.com

Address: 9F.-1, No. 171,
Bizhong St., Yancheng Dist.,
Kaohsiung City 803002, Taiwan (R.O.C.)

www.cainton.com