



CAINTON

Change is a perpetual motion

DC Cross Flow Fan

- Code Rule - p.1
- DC Cross Flow Fan - pp. 2 - 59

Code Rule

Fan Type	Fan imension (mm)		Voltage	Speed	Connection	Mold Model	IP Level
	Impeller Diameter	Air Outlet Length					
FLA: DC Cross Flow Fan			V12: 12VDC	HX: Higher than Extreme	C: Connector	-Mold Model	-IP Level
			V24: 24VDC	XH: Extremely High			
			V48: 48VDC	HH: Much Higher			
			FV: Full Voltage	HR: Higher			
				H: High			
				M: Medium			
				L: Low			
				LR: Lower			
				LW: Much Lower			
				XL: Extremely Low			
				LX: Lower than Extreme			

DC Cross Flow Fan

Ø30

- Housing: Metal
- Impeller: Aluminum
- Motor: Brushless DC Motor
- Certification: CE, RoHS
- Additional functions are optional



Model	Voltage	Current	Power	Speed	Air Flow	Pressure	Noise
	VDC	Amp	Watt	RPM	m3/h	Pa	dB(A)
FLD3098V12-M	12	0.08	0.96	3000	35	17	29
FLD3098V24-M	24	0.03	0.72	2800	35	17	29
FLD30160V12-M	12	0.11	1.32	2700	42	15	30
FLD30160V24-M	24	0.04	0.96	3000	42	15	30
FLD30198V12-M	12	0.13	1.56	2700	52	14	31
FLD30198V24-M	24	0.05	1.2	2500	52	14	31
FLD30248V12-M	12	0.28	3.36	3000	55	14	32
FLD30248V24-M	24	0.11	2.64	3000	55	14	32

DC Cross Flow Fan

Ø30

- Housing: Metal
- Impeller: Aluminum
- Motor: Brushless DC Motor
- Certification: CE, RoHS
- Additional functions are optional



Model	Voltage	Current	Power	Speed	Air Flow	Pressure	Noise
	VDC	Amp	Watt	RPM	m3/h	Pa	dB(A)
FLD30300V12-M	12	0.31	3.72	2800	72	13	33
FLD30300V24-M	24	0.12	2.88	2800	72	13	33
FLD30352V12-M	12	0.35	4.2	2500	84	13	34
FLD30352V24-M	24	0.14	3.36	2550	84	13	34
FLD30420V12-M	12	0.36	4.32	2400	105	14	35
FLD30420V24-M	24	0.14	3.36	2400	105	14	35

DC Cross Flow Fan

Ø30

- Dimension:

Unit: mm

Model	Air Outlet Length (C)	Pitch Row (B)	Total Length (A)	Curve
	mm	mm	mm	
FLD3098V12-M	98	132	145	Ⓐ
FLD3098V24-M	98	132	145	Ⓐ
FLD30160V12-M	160	194	207	Ⓑ
FLD30160V24-M	160	194	207	Ⓑ
FLD30198V12-M	198	232	245	Ⓒ
FLD30198V24-M	198	232	245	Ⓒ
FLD30248V12-M	248	282	295	Ⓓ
FLD30248V24-M	248	282	295	Ⓓ

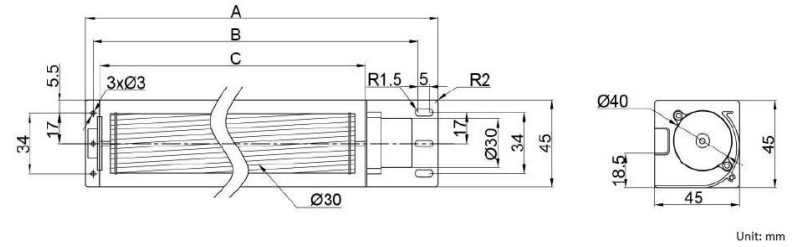

DC Cross Flow Fan

Ø30

- Dimension:
Unit: mm

Model	Air Outlet Length (C)	Pitch Row (B)	Total Length (A)	Curve
	mm	mm	mm	
FLD30300V12-M	300	334	347	Ⓔ
FLD30300V24-M	300	334	347	Ⓔ
FLD30352V12-M	352	386	399	Ⓕ
FLD30352V24-M	352	386	399	Ⓕ
FLD30420V12-M	420	454	467	Ⓖ
FLD30420V24-M	420	454	467	Ⓖ

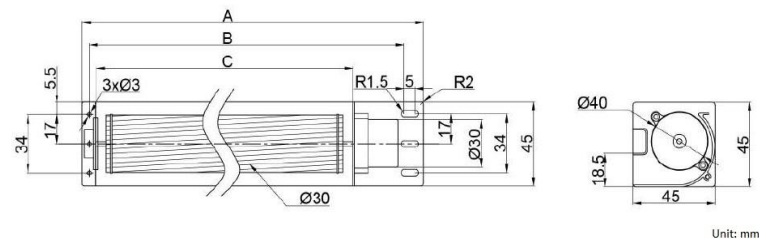

DC Cross Flow Fan

Ø30

- Performance:

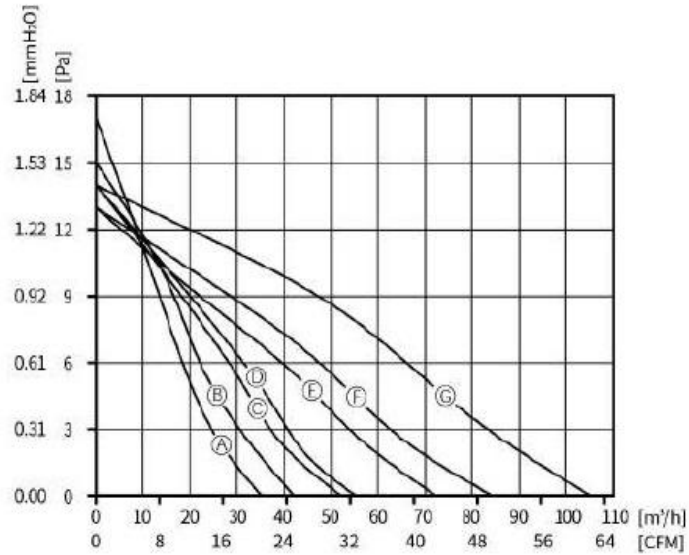

DC Cross Flow Fan

Ø30 - B Type

- Housing: Metal
- Impeller: Aluminum
- Motor: Brushless DC Motor
- Certification: CE, RoHS
- Additional functions are optional



Model	Voltage	Current	Power	Speed	Air Flow	Pressure	Noise
	VDC	Amp	Watt	RPM	m3/h	Pa	dB(A)
FLD3098V12-M2	12	0.1	1.2	3000	35	17	29
FLD3098V24-M2	24	0.05	1.2	3000	35	17	29
FLD30160V12-M2	12	0.12	1.44	2800	42	15	30
FLD30160V24-M2	24	0.07	1.68	2800	42	15	30
FLD30198V12-M2	12	0.14	1.68	2700	52	14	31
FLD30198V24-M2	24	0.08	1.92	2700	52	14	31

DC Cross Flow Fan

Ø30 - B Type

- Housing: Metal
- Impeller: Aluminum
- Motor: Brushless DC Motor
- Certification: CE, RoHS
- Additional functions are optional



Model	Voltage	Current	Power	Speed	Air Flow	Pressure	Noise
	VDC	Amp	Watt	RPM	m3/h	Pa	dB(A)
FLD30248V12-M2	12	0.16	1.92	2600	65	14	32
FLD30248V24-M2	24	0.09	2.16	2600	65	14	32
FLD30300V12-M2	12	0.18	2.16	2500	72	13	33
FLD30300V24-M2	24	0.09	2.16	2500	72	13	33
FLD30352V12-M2	12	0.2	2.4	2400	84	13	35
FLD30352V24-M2	24	0.1	2.4	2400	84	13	35

DC Cross Flow Fan

Ø30 - B Type

- Dimension:

Unit: mm

Model	Air Outlet Length (C)	Pitch Row (B)	Total Length (A)	Curve
	mm	mm	mm	
FLD3098V12-M2	98	108	152	Ⓐ
FLD3098V24-M2	98	108	152	Ⓐ
FLD30160V12-M2	160	170	214	Ⓑ
FLD30160V24-M2	160	170	214	Ⓑ
FLD30198V12-M2	198	208	252	Ⓒ
FLD30198V24-M2	198	208	252	Ⓒ
FLD30248V12-M2	248	258	302	Ⓓ
FLD30248V24-M2	248	258	302	Ⓓ
FLD30300V12-M2	300	310	354	Ⓔ
FLD30300V24-M2	300	310	354	Ⓔ
FLD30352V12-M2	352	362	406	Ⓕ
FLD30352V24-M2	352	362	406	Ⓕ

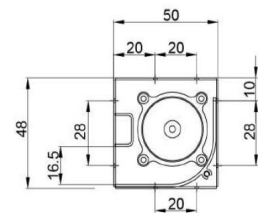
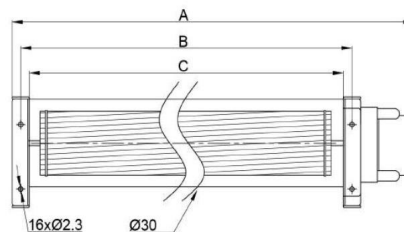

Unit: mm

DC Cross Flow Fan

Ø30 - B Type

- Performance:

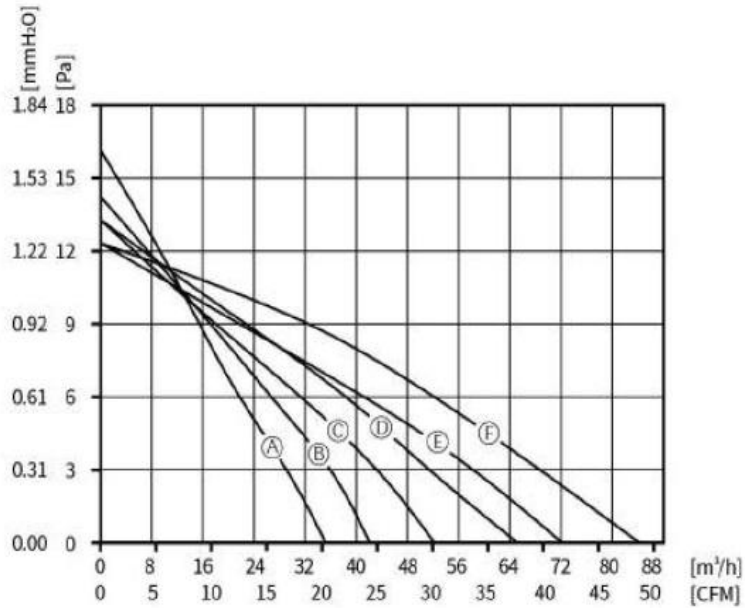

DC Cross Fan

Ø30 - C Type

- Housing: Metal
- Impeller: Aluminum
- Motor: Brushless DC Motor
- Certification: CE, RoHS
- Additional functions are optional



Model	Voltage	Current	Power	Speed	Air Flow	Pressure	Noise
	VDC	Amp	Watt	RPM	m3/h	Pa	dB(A)
FLD30530V12-M3	12	0.28	3.36	2400	85	18	32
FLD30530V24-M3	24	0.12	2.88	2400	85	18	32
FLD30610V12-M3	12	0.32	3.84	2400	100	18	33
FLD30610V24-M3	24	0.16	3.84	2400	100	18	33
FLD30650V12-M3	12	0.32	3.84	2400	105	17	34
FLD30650V24-M3	24	0.17	4.08	2400	105	17	34

DC Cross Flow Fan

Ø30 - C Type

- Housing: Metal
- Impeller: Aluminum
- Motor: Brushless DC Motor
- Certification: CE, RoHS
- Additional functions are optional



Model	Voltage	Current	Power	Speed	Air Flow	Pressure	Noise
	VDC	Amp	Watt	RPM	m3/h	Pa	dB(A)
FLD30718V12-M3	12	0.35	4.2	2400	115	17	35
FLD30718V24-M3	24	0.18	4.32	2400	115	17	35
FLD30800V12-M3	12	0.39	4.66	2400	130	17	36
FLD30800V24-M3	24	0.19	4.56	2400	130	17	36
FLD30854V12-M3	12	0.42	5.04	2400	140	17	36
FLD30854V24-M3	24	0.22	5.28	2400	140	17	36

DC Cross Flow Fan

Ø30 - C Type

- Housing: Metal
- Impeller: Aluminum
- Motor: Brushless DC Motor
- Certification: CE, RoHS
- Additional functions are optional



Model	Voltage	Current	Power	Speed	Air Flow	Pressure	Noise
	VDC	Amp	Watt	RPM	m3/h	Pa	dB(A)
FLD30854V12-M3	12	0.45	5.4	2400	150	17	37
FLD30854V24-M3	24	0.24	5.76	2400	150	17	37
FLD30986V12-M3	12	0.5	6	2400	160	17	37
FLD30986V24-M3	24	0.27	6.48	2400	160	17	37
FLD301082V12-M3	12	0.6	7.2	2400	175	17	38
FLD301082V24-M3	24	0.31	7.44	2400	175	17	38

DC Cross Flow Fan

Ø30 - C Type

- Dimension:

Unit: mm

Model	Air Outlet Length (C)	Pitch Row (B)	Total Length (A)	Curve
	mm	mm	mm	
FLD30530V12-M3	530	540	583.5	Ⓐ
FLD30530V24-M3	530	540	583.5	Ⓐ
FLD30610V12-M3	610	620	663.5	Ⓑ
FLD30610V24-M3	610	620	663.5	Ⓑ
FLD30650V12-M3	650	660	703.5	Ⓒ
FLD30650V24-M3	650	660	703.5	Ⓒ

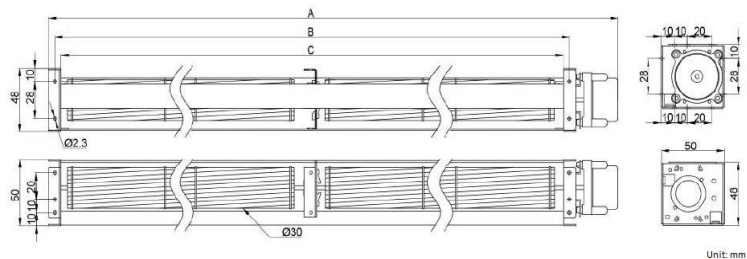

DC Cross Flow Fan

Ø30 - C Type

- Dimension:
Unit: mm

Model	Air Outlet Length (C)	Pitch Row (B)	Total Length (A)	Curve
	mm	mm	mm	
FLD30718V12-M3	718	728	771.5	Ⓓ
FLD30718V24-M3	718	728	771.5	Ⓓ
FLD30800V12-M3	800	810	853.5	Ⓔ
FLD30800V24-M3	800	810	853.5	Ⓔ
FLD30854V12-M3	854	864	907.5	Ⓕ
FLD30854V24-M3	854	864	907.5	Ⓕ

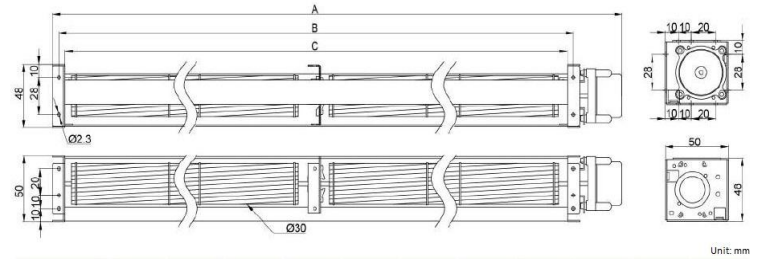

DC Cross Flow Fan

Ø30 - C Type

- Dimension:

Unit: mm

Model	Air Outlet Length (C)	Pitch Row (B)	Total Length (A)	Curve
	mm	mm	mm	
FLD30854V12-M3	920	930	973.5	Ⓒ
FLD30854V24-M3	920	930	973.5	Ⓒ
FLD30986V12-M3	986	996	1039.5	Ⓗ
FLD30986V24-M3	986	996	1039.5	Ⓗ
FLD301082V12-M3	1082	1092	1135.5	Ⓘ
FLD301082V24-M3	1082	1092	1135.5	Ⓘ

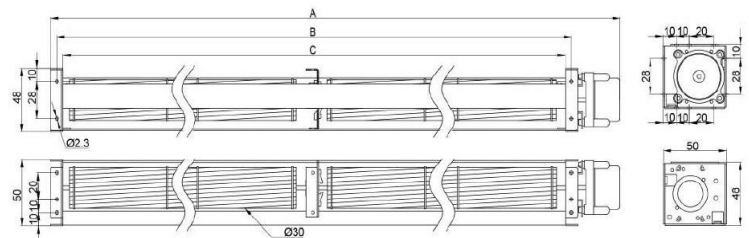

DC Cross Flow Fan

Ø30 - C Type

- Performance:

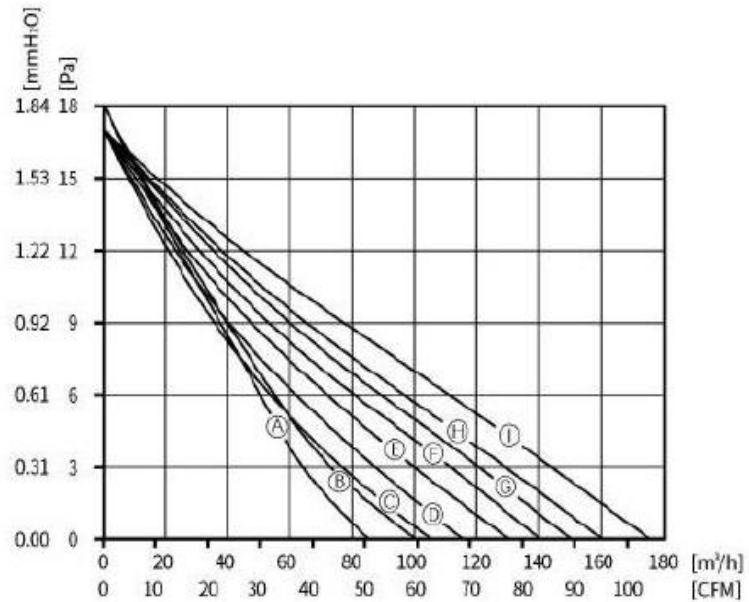

DC Cross Flow Fan

Ø40

- Housing: Metal
- Impeller: Aluminum
- Motor: Brushless DC Motor
- Certification: CE, RoHS
- Additional functions are optional



Model	Voltage	Current	Power	Speed	Air Flow	Pressure	Noise
	VDC	Amp	Watt	RPM	m3/h	Pa	dB(A)
FLD4098V12-M	12	0.12	1.44	2600	30	15	30
FLD4098V24-M	24	0.08	1.92	2600	30	15	30
FLD40160V12-M	12	0.16	1.92	2600	65	20	33
FLD40160V24-M	24	0.11	2.64	2600	65	20	33
FLD40198V12-M	12	0.2	2.4	2600	92	25	34
FLD40198V24-M	24	0.17	4.08	2600	92	25	34
FLD40250V12-M	12	0.25	3	2600	116	27	35
FLD40250V24-M	24	0.21	5.04	2600	116	27	35

DC Cross Flow Fan

Ø40

- Housing: Metal
- Impeller: Aluminum
- Motor: Brushless DC Motor
- Certification: CE, RoHS
- Additional functions are optional



Model	Voltage	Current	Power	Speed	Air Flow	Pressure	Noise
	VDC	Amp	Watt	RPM	m3/h	Pa	dB(A)
FLD40300V12-M	12	0.31	3.72	2600	138	29	36
FLD40300V24-M	24	0.25	6	2600	138	29	36
FLD40348V12-M	12	0.38	4.56	2600	162	32	37
FLD40348V24-M	24	0.26	6.24	2600	162	32	37
FLD40420V12-M	12	0.46	5.52	2600	195	34	38
FLD40420V24-M	24	0.31	7.44	2600	195	34	38

DC Cross Flow Fan

Ø40

- Dimension:

Unit: mm

Model	Air Outlet Length (C)	Pitch Row (B)	Total Length (A)	Curve
	mm	mm	mm	
FLD4098V12-M	98	132	145	Ⓐ
FLD4098V24-M	98	132	145	Ⓐ
FLD40160V12-M	160	194	207	Ⓑ
FLD40160V24-M	160	194	207	Ⓑ
FLD40198V12-M	198	232	245	Ⓒ
FLD40198V24-M	198	232	245	Ⓒ
FLD40250V12-M	250	282	295	Ⓓ
FLD40250V24-M	250	282	295	Ⓓ

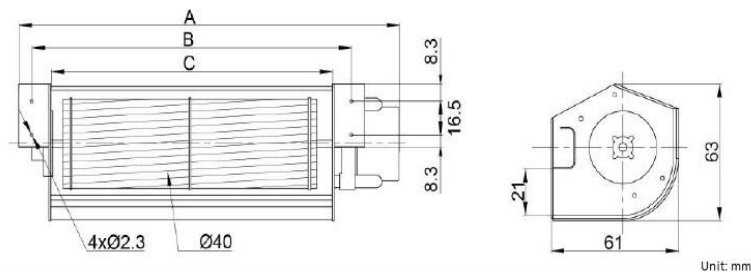

DC Cross Flow Fan

Ø40

- Dimension:

Unit: mm

Model	Air Outlet Length (C)	Pitch Row (B)	Total Length (A)	Curve
	mm	mm	mm	
FLD40300V12-M	300	334	347	Ⓔ
FLD40300V24-M	300	334	347	Ⓔ
FLD40348V12-M	348	386	399	Ⓕ
FLD40348V24-M	348	386	399	Ⓕ
FLD40420V12-M	420	454	467	Ⓖ
FLD40420V24-M	420	454	467	Ⓖ

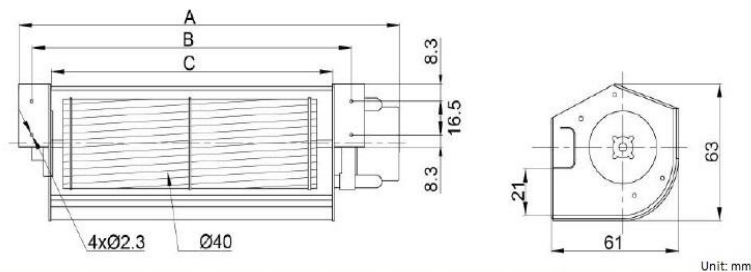

DC Cross Flow Fan

Ø40

- Performance:

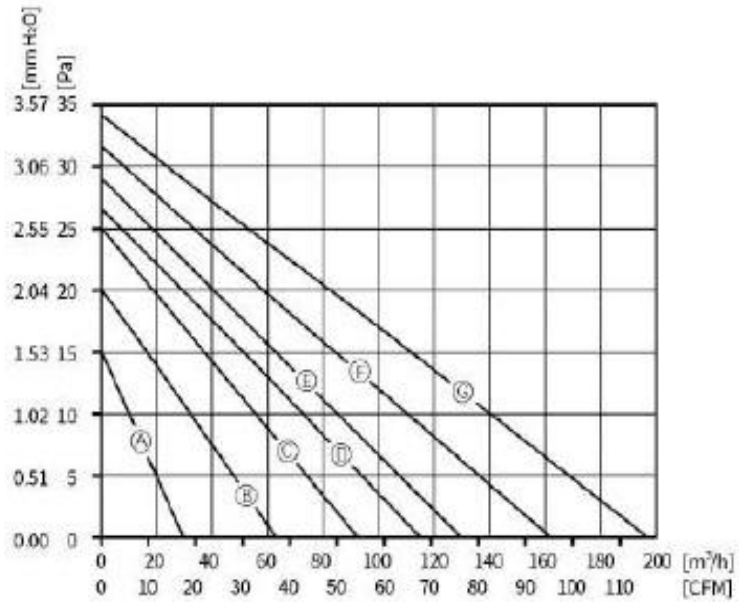

DC Cross Flow Fan

Ø40 - B Type

- Housing: Metal
- Impeller: Aluminum
- Motor: Brushless DC Motor
- Certification: CE, RoHS
- Additional functions are optional



Model	Voltage	Current	Power	Speed	Air Flow	Pressure	Noise
	VDC	Amp	Watt	RPM	m3/h	Pa	dB(A)
FLD4098V12-M2	12	0.12	1.44	2600	30	15	30
FLD4098V24-M2	24	0.08	1.92	2600	30	15	30
FLD40160V12-M2	12	0.16	1.92	2600	65	20	33
FLD40160V24-M2	24	0.11	2.64	2600	65	20	33
FLD40198V12-M2	12	0.2	2.4	2600	92	25	34
FLD40198V24-M2	24	0.17	4.08	2600	92	25	34
FLD40250V12-M2	12	0.25	3	2600	116	27	35
FLD40250V24-M2	24	0.21	5.04	2600	116	27	35

DC Cross Flow Fan

Ø40 - B Type

- Housing: Metal
- Impeller: Aluminum
- Motor: Brushless DC Motor
- Certification: CE, RoHS
- Additional functions are optional



Model	Voltage	Current	Power	Speed	Air Flow	Pressure	Noise
	VDC	Amp	Watt	RPM	m3/h	Pa	dB(A)
FLD40300V12-M2	12	0.31	3.72	2600	138	29	36
FLD40300V24-M2	24	0.25	6	2600	138	29	36
FLD40348V12-M2	12	0.38	4.56	2600	162	32	37
FLD40348V24-M2	24	0.26	6.24	2600	162	32	37
FLD40420V12-M2	12	0.46	5.52	2600	195	34	38
FLD40420V24-M2	24	0.31	7.44	2600	195	34	38

DC Cross Flow Fan

Ø40 - B Type

- Dimension:

Unit: mm

Model	Air Outlet Length (C)	Pitch Row (B)	Total Length (A)	Curve
	mm	mm	mm	
FLD4098V12-M2	98	108	149	Ⓐ
FLD4098V24-M2	98	108	149	Ⓐ
FLD40160V12-M2	160	170	210	Ⓑ
FLD40160V24-M2	160	170	210	Ⓑ
FLD40198V12-M2	198	208	249	Ⓒ
FLD40198V24-M2	198	208	249	Ⓒ
FLD40250V12-M2	250	260	300	Ⓓ
FLD40250V24-M2	250	260	300	Ⓓ

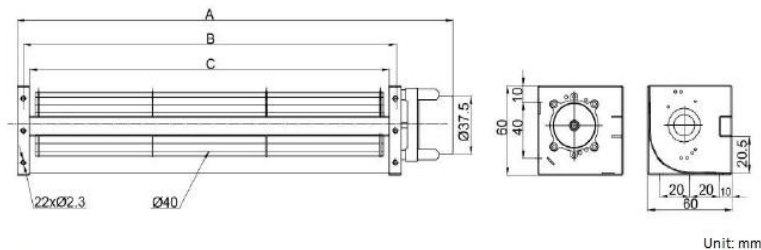

DC Cross Flow Fan

Ø40 - B Type

- Dimension:

Unit: mm

Model	Air Outlet Length (C)	Pitch Row (B)	Total Length (A)	Curve
	mm	mm	mm	
FLD40300V12-M2	300	310	352	Ⓔ
FLD40300V24-M2	300	310	352	Ⓔ
FLD40348V12-M2	348	358	417	Ⓕ
FLD40348V24-M2	348	358	417	Ⓕ
FLD40420V12-M2	420	430	472	Ⓖ
FLD40420V24-M2	420	430	472	Ⓖ

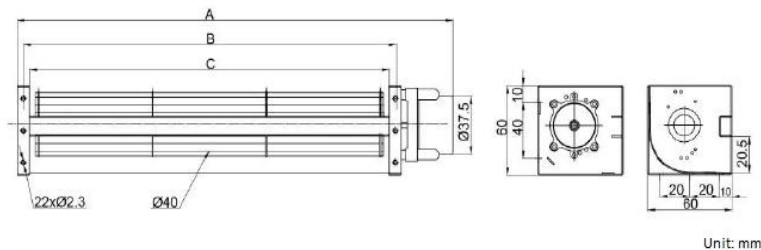

DC Cross Flow Fan

Ø40 - B Type

- Performance:

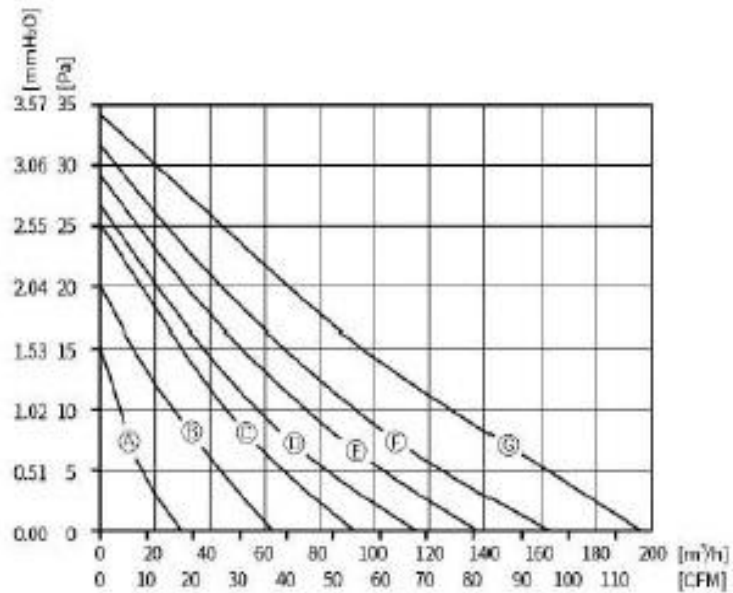

DC Cross Flow Fan

Ø40 - C Type

- Housing: Metal
- Impeller: Aluminum
- Motor: Brushless DC Motor
- Certification: CE, RoHS
- Additional functions are optional



Model	Voltage	Current	Power	Speed	Air Flow	Pressure	Noise
	VDC	Amp	Watt	RPM	m3/h	Pa	dB(A)
FLD40530V24-M3	24	0.24	5.76	2200	150	19	34
FLD40610V24-M3	24	0.29	6.96	2200	170	19	35
FLD40700V24-M3	24	0.17	4.08	2600	195	19	35
FLD40800V24-M3	24	0.21	5.04	2600	220	18	36
FLD40854V24-M3	24	0.25	6	2600	235	18	36
FLD40920V24-M3	24	0.26	6.24	2600	253	18	37
FLD401055V24-M3	24	0.31	7.44	2600	290	18	38

DC Cross Flow Fan

Ø40 - C Type

- Dimension:

Unit: mm

Model	Air Outlet Length (C)	Pitch Row (B)	Total Length (A)	Curve
	mm	mm	mm	
FLD40530V24-M3	530	540	580	Ⓐ
FLD40610V24-M3	610	620	670	Ⓑ
FLD40700V24-M3	700	710	750	Ⓒ
FLD40800V24-M3	800	810	850	Ⓓ
FLD40854V24-M3	854	864	904	Ⓔ
FLD40920V24-M3	920	930	973	Ⓕ
FLD401055V24-M3	1055	1065	1108	Ⓖ

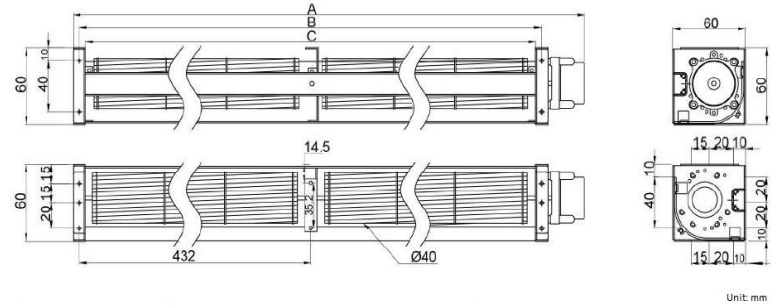

Unit: mm

DC Cross Flow Fan

Ø40 - C Type

- Performance:

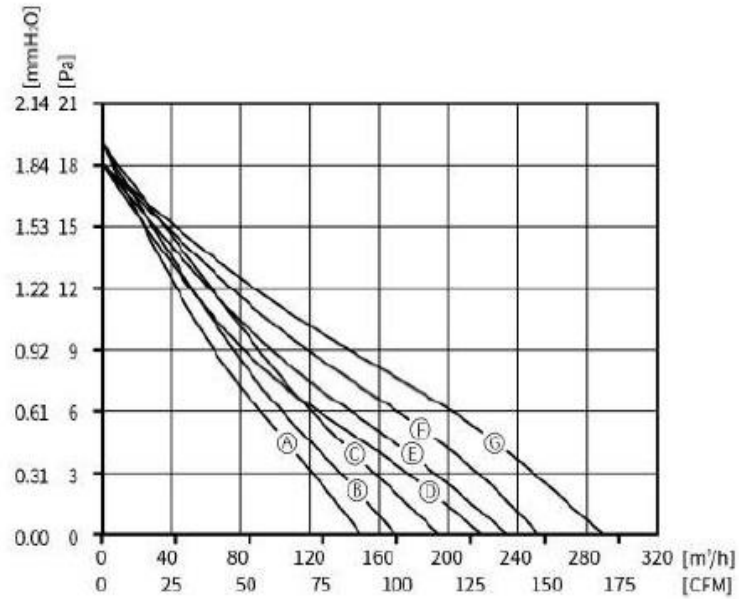

DC Cross Flow Fan

Ø43

- Housing: Metal
- Impeller: Aluminum
- Motor: Brushless DC Motor
- Certification: CE, RoHS
- Additional functions are optional



Model	Voltage	Current	Power	Speed	Air Flow	Pressure	Noise
	VDC	Amp	Watt	RPM	m3/h	Pa	dB(A)
FLD4398V12-M	12	0.28	3.36	2600	63	14	36
FLD4398V24-M	24	0.12	2.88	2600	63	14	36
FLD43160V12-M	12	0.32	3.84	2600	85	15	36
FLD43160V24-M	24	0.16	3.84	2600	85	15	36
FLD43198V12-M	12	0.36	4.32	2600	105	15	37
FLD43198V24-M	24	0.18	4.32	2600	105	15	37
FLD43250V12-M	12	0.43	5.16	2600	133	16	37
FLD43250V24-M	24	0.24	5.16	2600	133	16	37
FLD43300V12-M	12	0.46	5.52	2600	160	17	38
FLD43300V24-M	24	0.27	6.48	2600	160	17	38
FLD43348V12-M	12	0.5	6	2600	185	18	39
FLD43348V24-M	24	0.29	6.96	2600	185	18	39
FLD43420V12-M	12	0.52	6.24	2600	202	19	40
FLD43420V24-M	24	0.33	7.92	2600	202	19	40

DC Cross Flow Fan

Ø43

- Dimension:

Unit: mm

Model	Air Outlet Length (C)	Pitch Row (B)	Total Length (A)	Curve
	mm	mm	mm	
FLD4398V12-M	98	108	150	Ⓐ
FLD4398V24-M	98	108	150	Ⓐ
FLD43160V12-M	160	170	212	Ⓑ
FLD43160V24-M	160	170	212	Ⓑ
FLD43198V12-M	198	208	250	Ⓒ
FLD43198V24-M	198	208	250	Ⓒ
FLD43250V12-M	250	260	302	Ⓓ
FLD43250V24-M	250	260	302	Ⓓ
FLD43300V12-M	300	310	352	Ⓔ
FLD43300V24-M	300	310	352	Ⓔ
FLD43348V12-M	348	358	400	Ⓕ
FLD43348V24-M	348	358	400	Ⓕ
FLD43420V12-M	420	430	472	Ⓖ
FLD43420V24-M	420	430	472	Ⓖ

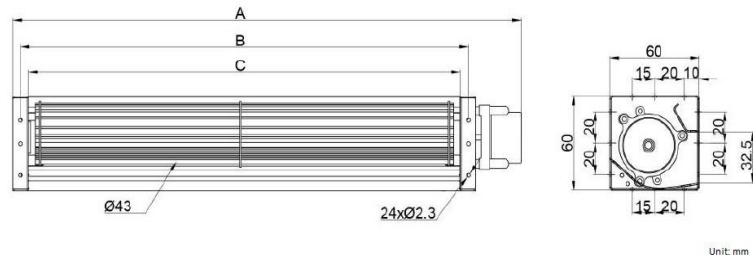

DC Cross Flow Fan

Ø43

- Performance:

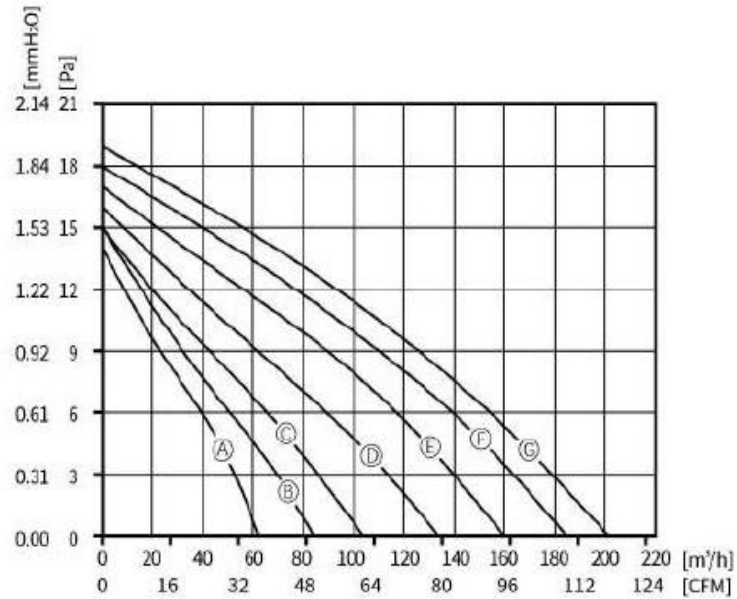

DC Cross Flow Fan

Ø45

- Housing: Metal
- Impeller: Aluminum
- Motor: Brushless DC Motor
- Certification: CE, RoHS
- Additional functions are optional



Model	Voltage	Current	Power	Speed	Air Flow	Pressure	Noise
	VDC	Amp	Watt	RPM	m3/h	Pa	dB(A)
FLD45530V24-M	24	0.49	11.76	2000	366	28	48
FLD45630V24-M	24	0.7	16.8	2000	384	28	49
FLD45700V24-M	24	0.85	20.4	2000	430	28	50
FLD45750V24-M	24	0.94	22.56	2000	495	28	50
FLD45820V24-M	24	0.82	19.68	1800	487	25	48
FLD45870V24-M	24	0.85	20.4	1800	516	25	48

DC Cross Flow Fan

Ø45

- Dimension:

Unit: mm

Model	Air Outlet Length (C)	Pitch Row (B)	Total Length (A)	Curve
	mm	mm	mm	
FLD45530V24-M	530	540	585	Ⓐ
FLD45630V24-M	630	640	685	Ⓑ
FLD45700V24-M	700	710	755	Ⓒ
FLD45750V24-M	750	760	805	Ⓓ
FLD45820V24-M	820	830	875	Ⓔ
FLD45870V24-M	870	880	925	Ⓕ

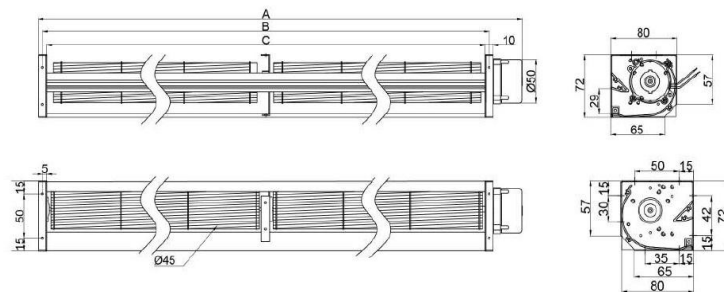

Unit: mm

DC Cross Flow Fan

Ø45

- Performance:

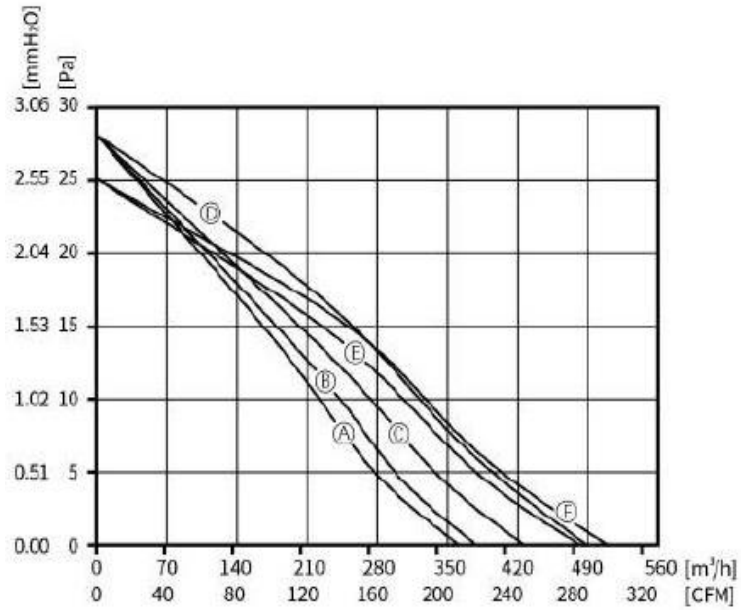

DC Cross Flow Fan

Ø50

- Housing: Metal
- Impeller: Aluminum
- Motor: Brushless DC Motor
- Certification: CE, RoHS
- Additional functions are optional



Model	Voltage	Current	Power	Speed	Air Flow	Pressure	Noise
	VDC	Amp	Watt	RPM	m3/h	Pa	dB(A)
FLD5098V12-M	12	0.2	2.4	2400	60	40	34
FLD5098V24-M	24	0.12	2.88	2400	60	40	34
FLD50158V12-M	12	0.44	5.28	2400	110	45	42
FLD50158V24-M	24	0.24	5.76	2400	110	45	42
FLD50198V12-M	12	0.6	7.2	2400	150	45	43
FLD50198V24-M	24	0.28	6.72	2400	150	45	43
FLD50248V12-M	12	0.66	7.92	2400	210	45	44
FLD50248V24-M	24	0.33	7.92	2400	210	45	44

DC Cross Flow Fan

Ø50

- Housing: Metal
- Impeller: Aluminum
- Motor: Brushless DC Motor
- Certification: CE, RoHS
- Additional functions are optional



Model	Voltage	Current	Power	Speed	Air Flow	Pressure	Noise
	VDC	Amp	Watt	RPM	m3/h	Pa	dB(A)
FLD50290V12-M	12	0.91	10.92	2400	260	45	44
FLD50290V24-M	24	0.43	10.32	2400	260	45	44
FLD50358V12-M	12	1.13	13.56	2400	330	45	43
FLD50358V24-M	24	0.57	13.68	2400	330	45	43
FLD50418V12-M	12	1.16	13.92	2400	395	45	43
FLD50418V24-M	24	0.61	14.64	2400	395	45	43

DC Cross Flow Fan

Ø50

- Dimension:

Unit: mm

Model	Air Outlet Length (C)	Pitch Row (B)	Total Length (A)	Curve
	mm	mm	mm	
FLD5098V12-M	98	108	166	Ⓐ
FLD5098V24-M	98	108	166	Ⓐ
FLD50158V12-M	158	168	226	Ⓑ
FLD50158V24-M	158	168	226	Ⓑ
FLD50198V12-M	198	208	266	Ⓒ
FLD50198V24-M	198	208	266	Ⓒ
FLD50248V12-M	248	258	310	Ⓓ
FLD50248V24-M	248	258	310	Ⓓ
FLD50290V12-M	290	308	363	Ⓔ
FLD50290V24-M	290	308	363	Ⓔ
FLD50358V12-M	358	368	422	Ⓕ
FLD50358V24-M	358	368	422	Ⓕ
FLD50418V12-M	418	428	476	Ⓖ
FLD50418V24-M	418	428	476	Ⓖ

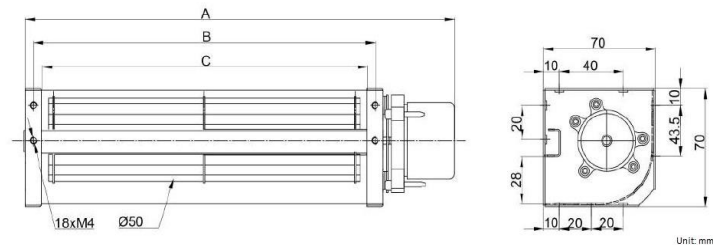

DC Cross Flow Fan

Ø50

- Performance:

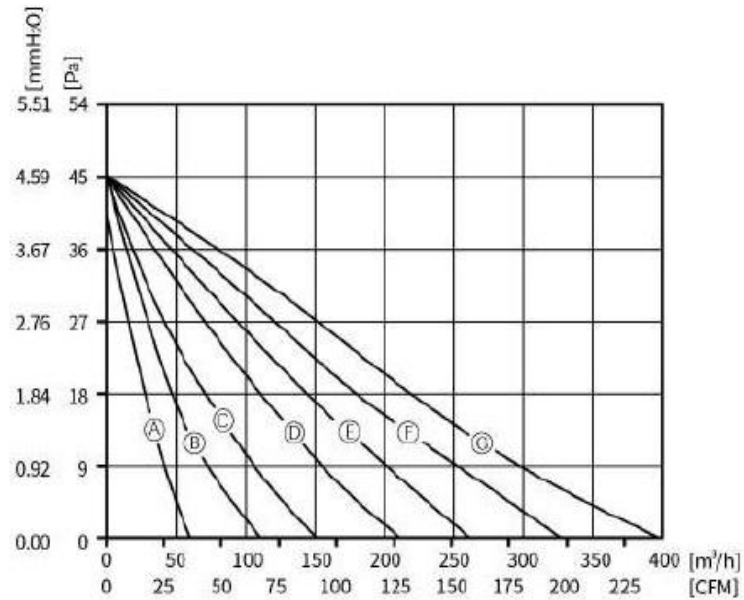

DC Cross Flow Fan

Ø50 - B Type

- Housing: Metal
- Impeller: Aluminum
- Motor: Brushless DC Motor
- Certification: CE, RoHS
- Additional functions are optional



Model	Voltage	Current	Power	Speed	Air Flow	Pressure	Noise
	VDC	Amp	Watt	RPM	m3/h	Pa	dB(A)
FLD50100V12-M2	12	0.16	1.92	2400	50	35	38
FLD50100V24-M2	24	0.1	2.4	2400	50	35	38
FLD50160V12-M2	12	0.26	3.12	2400	90	39	39
FLD50160V24-M2	24	0.13	3.12	2400	90	39	39
FLD50200V12-M2	12	0.3	3.6	2400	120	42	41
FLD50200V24-M2	24	0.17	4.08	2400	120	42	41
FLD50250V12-M2	12	0.33	3.96	2400	150	42	42
FLD50250V24-M2	24	0.18	4.32	2400	150	42	42

DC Cross Flow Fan

Ø50 - B Type

- Housing: Metal
- Impeller: Aluminum
- Motor: Brushless DC Motor
- Certification: CE, RoHS
- Additional functions are optional



Model	Voltage	Current	Power	Speed	Air Flow	Pressure	Noise
	VDC	Amp	Watt	RPM	m3/h	Pa	dB(A)
FLD50300V12-M2	12	0.4	4.8	2400	180	42	43
FLD50300V24-M2	24	0.2	4.8	2400	180	42	43
FLD50360V12-M2	12	0.44	5.28	2400	210	42	44
FLD50360V24-M2	24	0.22	5.28	2400	210	42	44
FLD50420V12-M2	12	0.51	6.12	2400	250	42	46
FLD50420V24-M2	24	0.25	6	2400	250	42	46

DC Cross Flow Fan

Ø50 - B Type

- **Dimension:**
Unit: mm

Model	Air Outlet Length (C)	Pitch Row (B)	Total Length (A)	Curve
	mm	mm	mm	
FLD50100V12-M2	100	110	155	Ⓐ
FLD50100V24-M2	100	110	155	Ⓐ
FLD50160V12-M2	160	170	215	Ⓑ
FLD50160V24-M2	160	170	215	Ⓑ
FLD50200V12-M2	200	210	256	Ⓒ
FLD50200V24-M2	200	210	256	Ⓒ
FLD50250V12-M2	250	260	302	Ⓓ
FLD50250V24-M2	250	260	302	Ⓓ
FLD50300V12-M2	300	310	340	Ⓔ
FLD50300V24-M2	300	310	340	Ⓔ
FLD50360V12-M2	360	370	410	Ⓕ
FLD50360V24-M2	360	370	410	Ⓕ
FLD50420V12-M2	420	430	475	Ⓖ
FLD50420V24-M2	420	430	475	Ⓖ

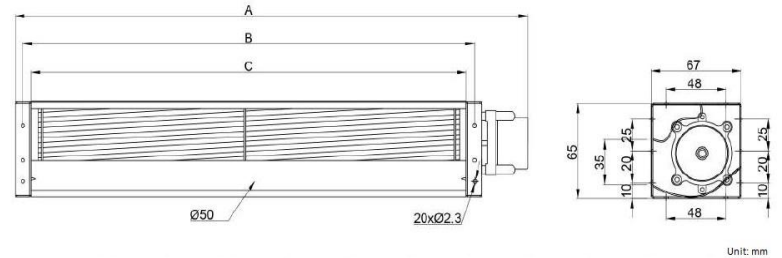

Unit: mm

DC Cross Flow Fan

Ø50 - B Type

- Performance:

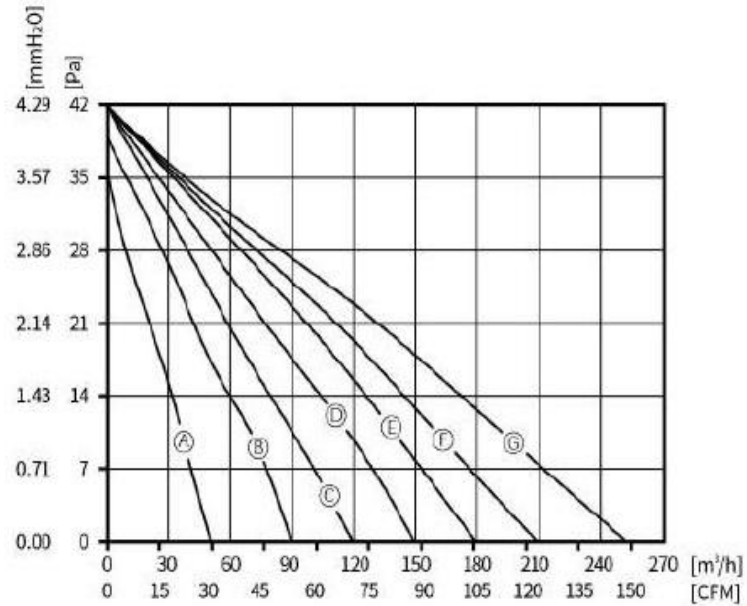

DC Cross Flow Fan

Ø60

- Housing: Metal
- Impeller: Aluminum
- Motor: Brushless DC Motor
- Certification: CE, RoHS
- Additional functions are optional



Model	Voltage	Current	Power	Speed	Air Flow	Pressure	Noise
	VDC	Amp	Watt	RPM	m3/h	Pa	dB(A)
FLD60123V12-M	12	0.74	8.88	2600	102	52	45
FLD60123V24-M	24	0.35	8.4	2600	102	52	45
FLD60184V12-M	12	1	12	2400	139	47	45
FLD60184V24-M	24	0.47	11.28	2350	139	47	45
FLD60245V12-M	12	1.2	14.4	2200	169	43	45
FLD60245V24-M	24	0.55	13.2	2200	169	43	45
FLD60306V12-M	12	1.35	16.2	2100	192	41	43
FLD60306V24-M	24	0.63	15.12	2000	192	41	43

DC Cross Flow Fan

Ø60

- Housing: Metal
- Impeller: Aluminum
- Motor: Brushless DC Motor
- Certification: CE, RoHS
- Additional functions are optional



Model	Voltage	Current	Power	Speed	Air Flow	Pressure	Noise
	VDC	Amp	Watt	RPM	m3/h	Pa	dB(A)
FLD60368V12-M	12	1.45	17.4	2000	212	38	43
FLD60368V24-M	24	0.67	16.08	1900	212	38	42
FLD60429V12-M	12	1.53	18.36	1900	254	36	42
FLD60429V24-M	24	0.73	17.52	1800	254	36	42
FLD60420V24HR-M	24	2.55	61.2	3200	537	86	56

DC Cross Flow Fan

Ø60

- Dimension:

Unit: mm

Model	Air Outlet Length (C)	Pitch Row (B)	Total Length (A)	Curve
	mm	mm	mm	
FLD60123V12-M	123	138	186	Ⓐ
FLD60123V24-M	123	138	186	Ⓐ
FLD60184V12-M	184	199	246	Ⓑ
FLD60184V24-M	184	199	246	Ⓑ
FLD60245V12-M	245	259	307	Ⓒ
FLD60245V24-M	245	259	307	Ⓒ
FLD60306V12-M	306	321	368	Ⓓ
FLD60306V24-M	306	321	368	Ⓓ
FLD60368V12-M	368	383	430	Ⓔ
FLD60368V24-M	368	383	430	Ⓔ
FLD60429V12-M	429	444	492	Ⓕ
FLD60429V24-M	429	444	492	Ⓕ
FLD60420V24HR-M	429	444	492	Ⓕ

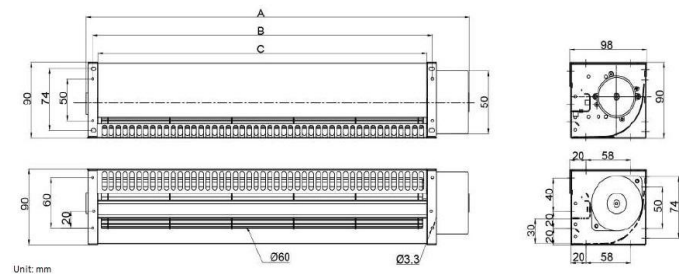

DC Cross Flow Fan

Ø60

- Performance:

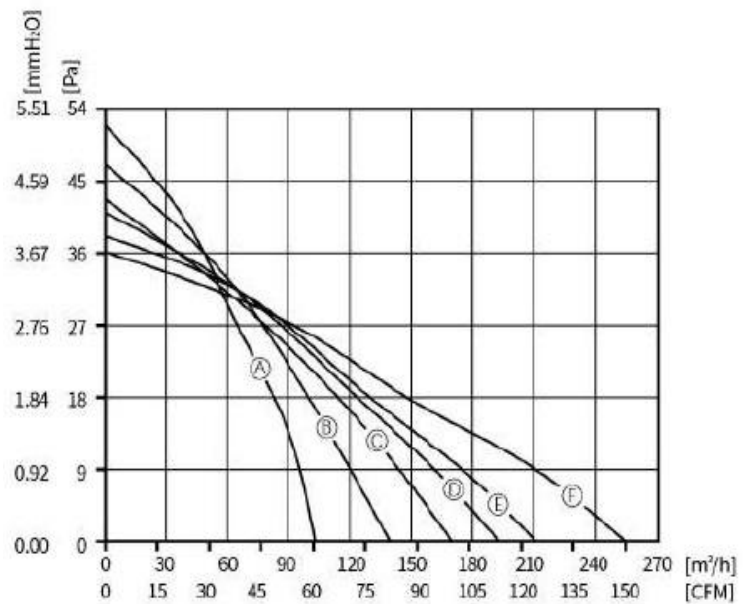

DC Cross Flow Fan

Ø60 - B Type

- Housing: Metal
- Impeller: Aluminum
- Motor: Brushless DC Motor
- Certification: CE, RoHS
- Additional functions are optional



Model	Voltage	Current	Power	Speed	Air Flow	Pressure	Noise
	VDC	Amp	Watt	RPM	m3/h	Pa	dB(A)
FLD60250V24-M2	24	0.2	4.8	2400	152	22	40
FLD60310V24-M2	24	0.25	6	2400	186	24	40
FLD60350V24-M2	24	0.3	7.2	2400	212	24	41
FLD60425V24-M2	24	0.4	9.6	2400	277	24	42
FLD60520V24-M2	24	0.45	10.8	2400	315	24	43
FLD60610V24-M2	24	0.6	14.4	2400	380	24	44

DC Cross Flow Fan

Ø60 - B Type

- Housing: Metal
- Impeller: Aluminum
- Motor: Brushless DC Motor
- Certification: CE, RoHS
- Additional functions are optional



Model	Voltage	Current	Power	Speed	Air Flow	Pressure	Noise
	VDC	Amp	Watt	RPM	m3/h	Pa	dB(A)
FLD60750V24-M2	24	0.65	15.6	2400	440	24	44
FLD60870V24-M2	24	0.8	19.2	2400	510	24	46
FLD60920V24-M2	24	0.85	20.4	2400	540	24	46
FLD601080V24-M2	24	1	24	2400	630	24	47
FLD601300V24-M2	24	1.2	28.8	2400	760	24	47

DC Cross Flow Fan

Ø60 - B Type

- Dimension:

Unit: mm

Model	Air Outlet Length (C)	Pitch Row (B)	Total Length (A)	Curve
	mm	mm	mm	
FLD60250V24-M2	250	268	310	Ⓐ
FLD60310V24-M2	310	328	370	Ⓑ
FLD60350V24-M2	350	368	410	Ⓒ
FLD60425V24-M2	425	443	485	Ⓓ
FLD60520V24-M2	520	538	580	Ⓔ
FLD60610V24-M2	610	658	693	Ⓕ
FLD60750V24-M2	750	768	833	Ⓖ
FLD60870V24-M2	870	888	953	Ⓗ
FLD60920V24-M2	920	938	1003	Ⓐ
FLD601080V24-M2	1080	1098	1163	Ⓙ
FLD601300V24-M2	1300	1318	13863	Ⓚ

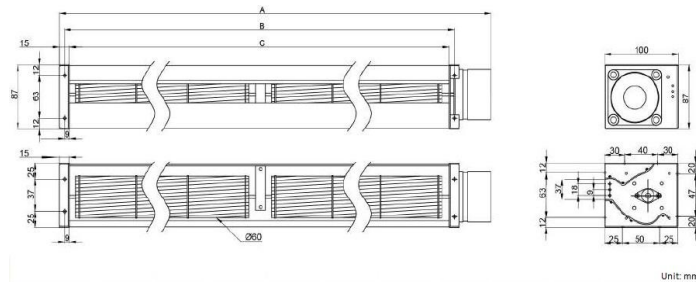

DC Cross Flow Fan

Ø60 - B Type

- Performance:

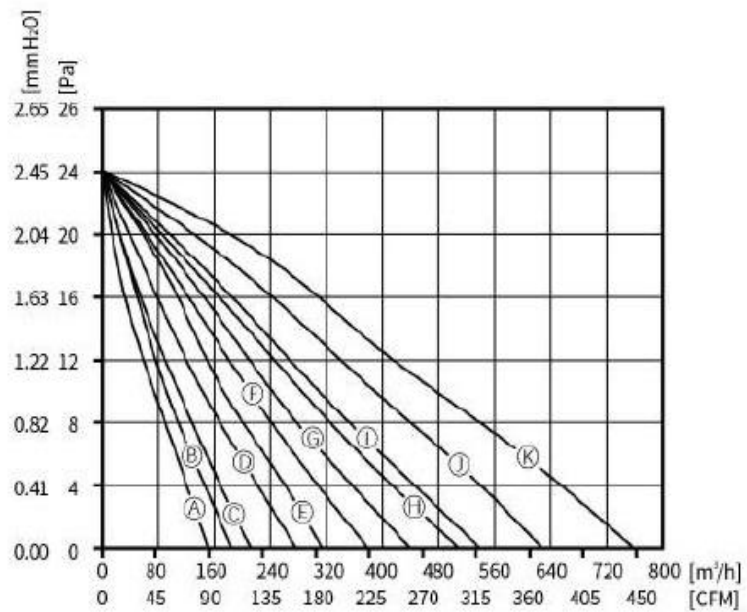

DC Cross Flow Fan

Ø60 - C Type

- Housing: Metal
- Impeller: Aluminum
- Motor: Brushless DC Motor
- Certification: CE, RoHS
- Additional functions are optional



Model	Voltage	Current	Power	Speed	Air Flow	Pressure	Noise
	VDC	Amp	Watt	RPM	m3/h	Pa	dB(A)
FLD60520V24-M3	24	0.6	14.4	1800	330	50	47
FLD60610V24-M3	24	0.6	14.4	1800	380	50	47
FLD60640V24-M3	24	0.7	16.8	1800	400	52	48
FLD60700V24-M3	24	0.7	16.8	1800	440	52	48
FLD60750V24-M3	24	0.8	19.2	1800	470	52	48
FLD60870V24-M3	24	1	24	1800	550	52	49
FLD601105V24-M3	24	1.5	36	1800	630	60	52
FLD601305V24-M3	24	2.2	52.8	1800	820	60	54

DC Cross Flow Fan

Ø60 - C Type

- Dimension:
Unit: mm

Model	Air Outlet Length (C)	Pitch Row (B)	Total Length (A)	Curve
	mm	mm	mm	
FLD60520V24-M3	520	535	600	Ⓐ
FLD60610V24-M3	610	625	690	Ⓑ
FLD60640V24-M3	640	655	720	Ⓒ
FLD60700V24-M3	700	715	780	Ⓓ
FLD60750V24-M3	750	765	830	Ⓔ
FLD60870V24-M3	870	885	950	Ⓕ
FLD601105V24-M3	1105	1120	1185	Ⓖ
FLD601305V24-M3	1305	1320	1385	Ⓗ

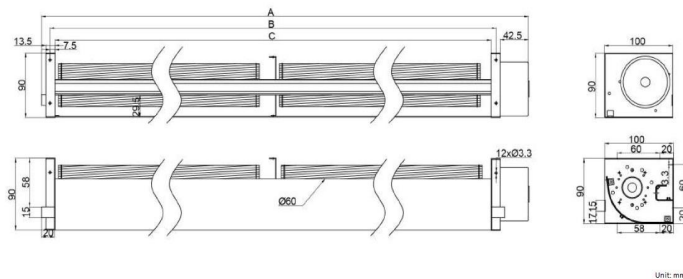

DC Cross Flow Fan

Ø60 - C Type

- Performance:

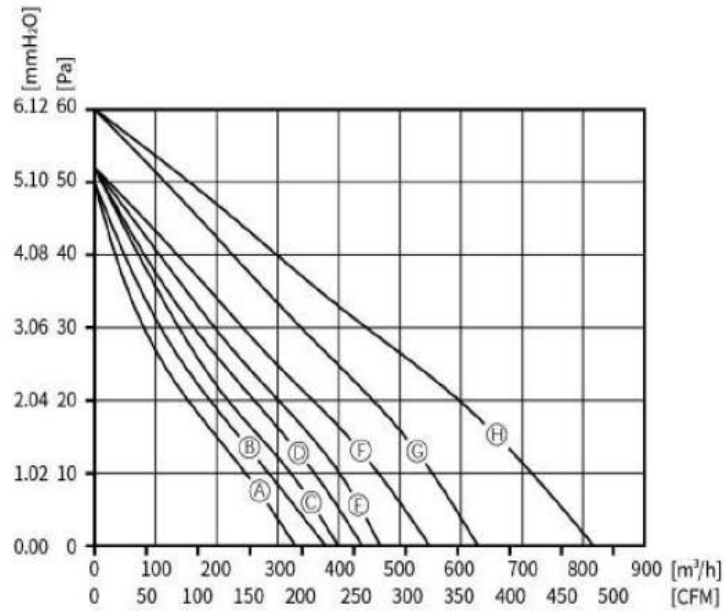

DC Cross Flow Fan

Ø65

- Housing: Metal
- Impeller: Aluminum
- Motor: Brushless DC Motor
- Certification: CE, RoHS
- Additional functions are optional



Model	Voltage	Current	Power	Speed	Air Flow	Pressure	Noise
	VDC	Amp	Watt	RPM	m3/h	Pa	dB(A)
FLD65520V12-M	12	2.7	32.4	1800	705	64	50
FLD65520V24-M	24	1.2	28.8	1800	705	64	51
FLD65620V12-M	12	2.5	30	1800	825	64	50
FLD65620V24-M	24	1.25	30	1800	825	64	50
FLD65720V12-M	12	2.6	31.2	1800	860	64	50
FLD65720V24-M	24	1.3	31.2	1800	860	64	50
FLD65750V12-M	12	2.8	33.6	1800	880	64	50
FLD65750V24-M	24	1.4	33.6	1800	880	64	50

DC Cross Flow Fan

Ø65

- Housing: Metal
- Impeller: Aluminum
- Motor: Brushless DC Motor
- Certification: CE, RoHS
- Additional functions are optional



Model	Voltage	Current	Power	Speed	Air Flow	Pressure	Noise
	VDC	Amp	Watt	RPM	m3/h	Pa	dB(A)
FLD65820V12-M	12	3	36	1800	920	65	53
FLD65820V24-M	24	1.5	36	1800	920	65	53
FLD65870V12-M	12	3.2	38.4	1800	970	65	53
FLD65870V24-M	24	1.6	38.4	1800	970	65	53
FLD651105V12-M	12	4.2	100.8	1600	1225	55	56
FLD651305V24-M	24	4.2	100.8	1600	1445	55	56

DC Cross Flow Fan

Ø65

- Dimension:

Unit: mm

Model	Air Outlet Length (C)	Pitch Row (B)	Total Length (A)	Curve
	mm	mm	mm	
FLD65520V12-M	520	532	589	Ⓐ
FLD65520V24-M	520	532	589	Ⓐ
FLD65620V12-M	620	632	659	Ⓑ
FLD65620V24-M	620	632	659	Ⓑ
FLD65720V12-M	720	732	789	Ⓒ
FLD65720V24-M	720	732	789	Ⓒ
FLD65750V12-M	750	762	819	Ⓓ
FLD65750V24-M	750	762	819	Ⓓ
FLD65820V12-M	820	832	889	Ⓔ
FLD65820V24-M	820	832	889	Ⓔ
FLD65870V12-M	870	882	939	Ⓕ
FLD65870V24-M	870	882	939	Ⓕ
FLD651105V12-M	1105	1117	1174	Ⓖ
FLD651305V24-M	1305	1317	1374	Ⓗ

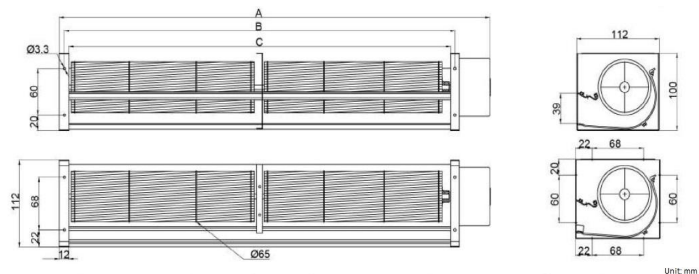

DC Cross Flow Fan

Ø65

- Performance:

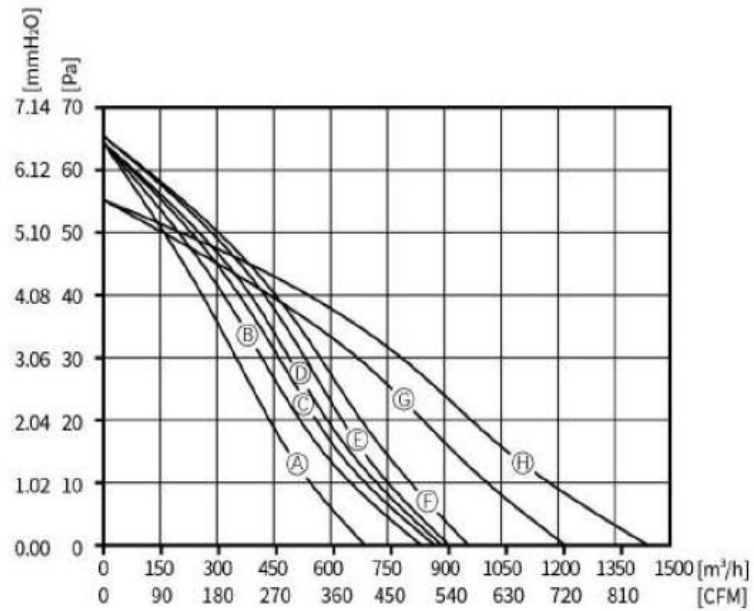



Change is a perpetual motion

Phone: +886-7-215-0001

Mobile: +886-938-016696

E-mail: service@cainton.com

Address: 9F.-1, No. 171,
Bizhong St., Yancheng Dist.,
Kaohsiung City 803002, Taiwan (R.O.C.)

www.cainton.com