



CAINTON

Change is a perpetual motion

EC Axial Fan

- Code Rule - p.1
- EC Axial Fan - pp. 2 - 36
- EC Outer Rotor Axial Fan - pp. 37 - 65

Code Rule

Fan Type	Fan Dimension (mm)		Voltage	Speed	Bearing	Connection	Function	Mold Model	IP Level
AXE: EC Axial Fan	Length	Thickness	V1: 110VAC	HX: Higher than Extreme	B: Ball Type	C: Connector	N1: FG	-Mold Model	-IP Level
OXE: EC Outer Rotor Axial Fan			V2: 220VAC	XH: Extremely High			N2: RD		
			V3: 380VAC	HH: Much Higher			N3: PWM		
			FV: Full Voltage	HR: Higher			N4: Voltage Control		
				H: High			N5: FG+PWM		
				M: Medium			N6: RD+PWM		
				L: Low			N7: FG+VC		
				LR: Lower			N8: RD+VC		
				LW: Much Lower					
				XL: Extremely Low					
			LX: Lower than Extreme						

EC Axial Fan

80x80x25mm - B Type

- Housing: Thermoplastic PBT (UL94V-0)
- Impeller: Thermoplastic PBT (UL94V-0)
- Bearing: Ball Type
- Certification: CE, RoHS
- Additional functions are optional



Model	Voltage	Frequency	Power	Speed	Air Flow		Pressure		Noise
	VAC	Hz	Watt	RPM	CFM	m3/min	mmH2O	inH2O	dB(A)
AXE8025V1HB-N 2	110	50/60	4	3000	40.2	1.14	4.57	0.18	38.5
AXE8025V2HB-N 2	220	50/60	4	3000	40.2	1.14	4.57	0.18	38.5

EC Axial Fan

80x80x25mm - B Type

- Dimension:

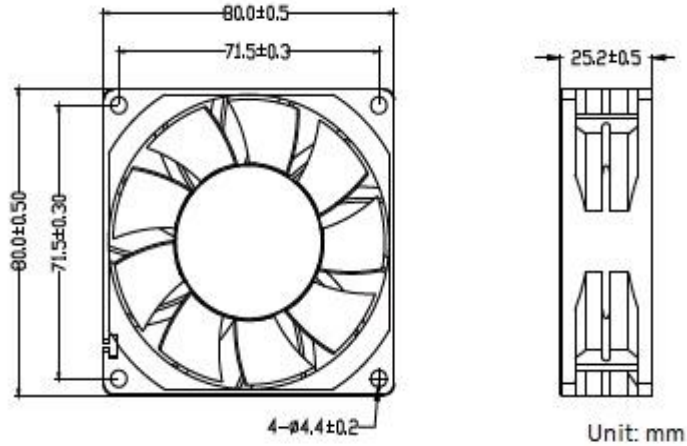

- Performance:

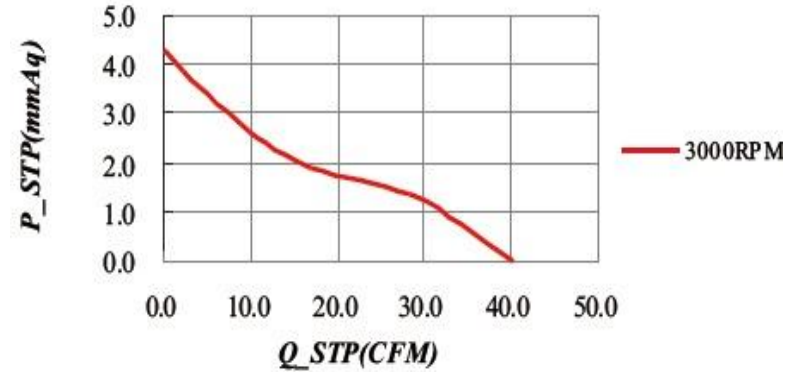

EC Axial Fan

80x80x38mm

- Housing: Thermoplastic PBT (UL94V-0)
- Impeller: Thermoplastic PBT (UL94V-0)
- Bearing: Ball Type
- Certification: CE, RoHS
- Additional functions are optional



Model	Voltage	Frequency	Power	Speed	Air Flow		Pressure		Noise
	VAC	Hz	Watt	RPM	CFM	m3/min	mmH2O	inH2O	dB(A)
AXE8038V1HB-N	110	50/60	9	5000	62.3	1.76	13.6	0.45	52.1
AXE8038V2HB-N	220	50/60	9	5000	62.3	1.76	13.6	0.45	52.1

EC Axial Fan

80x80x38mm

- Dimension:

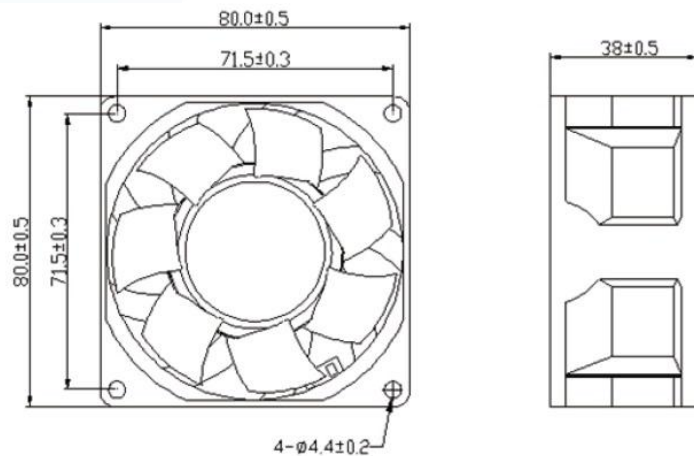

- Performance:

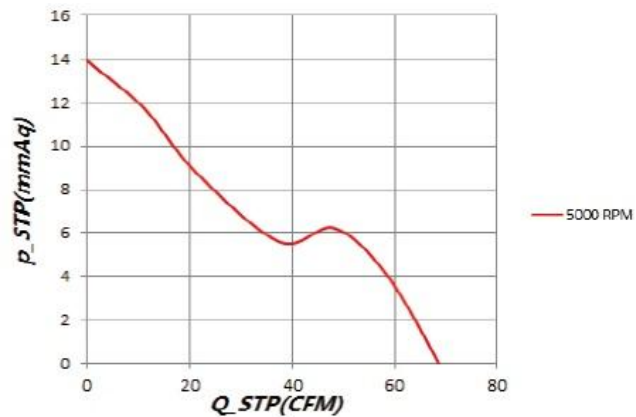

EC Axial Fan

92x92x25mm

- Housing: Thermoplastic PBT (UL94V-0)
- Impeller: Thermoplastic PBT (UL94V-0)
- Bearing: Ball Type
- Certification: CE, RoHS
- Additional functions are optional



Model	Voltage	Frequency	Power	Speed	Air Flow		Pressure		Noise
	VAC	Hz	Watt	RPM	CFM	m3/min	mmH2O	inH2O	dB(A)
AXE9225V1MB-N 2	110	50/60	4.5	2600	56	1.59	4.05	0.16	35
AXE9225V2MB-N 2	220	50/60	4.5	2600	56	1.59	4.05	0.16	35

EC Axial Fan

92x92x25mm

- Dimension:

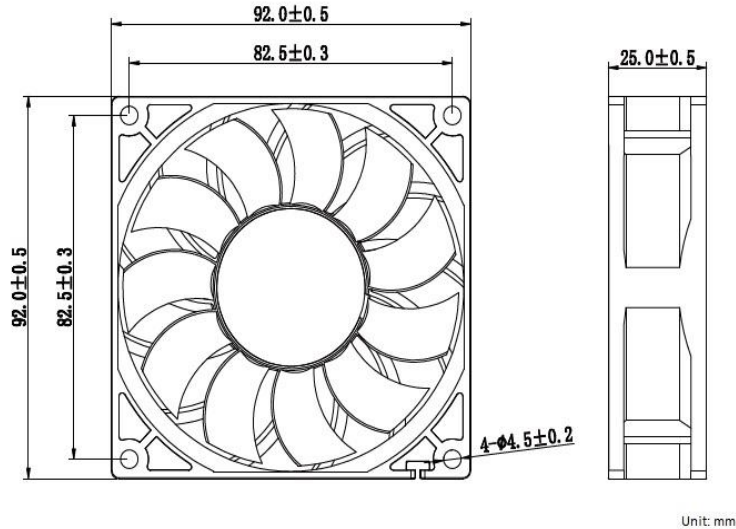

- Performance:

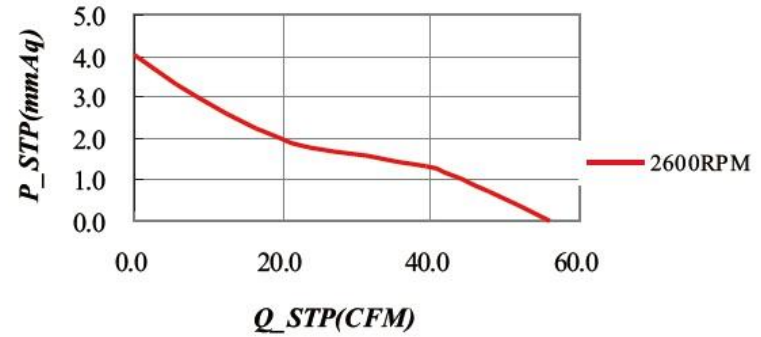

EC Axial Fan

92x92x32mm

- Housing: Thermoplastic PBT (UL94V-0)
- Impeller: Thermoplastic PBT (UL94V-0)
- Bearing: Ball Type
- Certification: CE, RoHS
- Additional functions are optional



Model	Voltage	Frequency	Power	Speed	Air Flow		Pressure		Noise
	VAC	Hz	Watt	RPM	CFM	m3/min	mmH2O	inH2O	dB(A)
AXE9232V1HB-N	110	50/60	6	3500	56.66	1.6	4.24	0.17	43.7
AXE9232V2HB-N	220	50/60	6	3500	56.66	1.6	4.24	0.17	43.7

EC Axial Fan

92x92x32mm

- Dimension:

Unit: mm

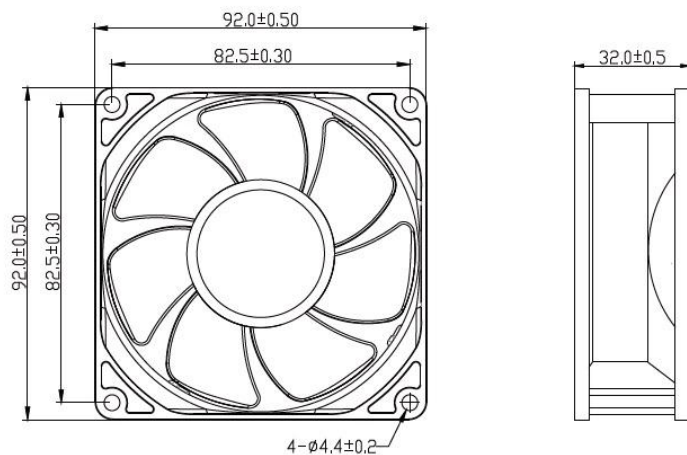

- Performance:

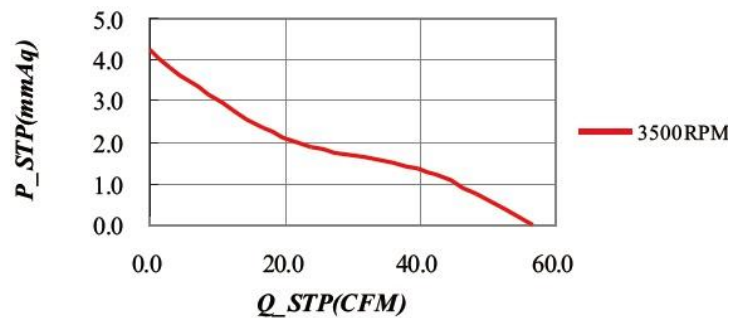

EC Axial Fan

92x92x38mm

- Housing: Thermoplastic PBT (UL94V-0)
- Impeller: Thermoplastic PBT (UL94V-0)
- Bearing: Ball Type
- Certification: CE, RoHS
- Additional functions are optional



Model	Voltage	Frequency	Power	Speed	Air Flow		Pressure		Noise
	VAC	Hz	Watt	RPM	CFM	m3/min	mmH2O	inH2O	dB(A)
AXE9238V1HB-N	110	50/60	11	4500	86.38	2.45	12.76	0.5	56
AXE9238V2HB-N	220	50/60	11	4500	86.38	2.45	12.76	0.5	56

EC Axial Fan

92x92x38mm

- Dimension:

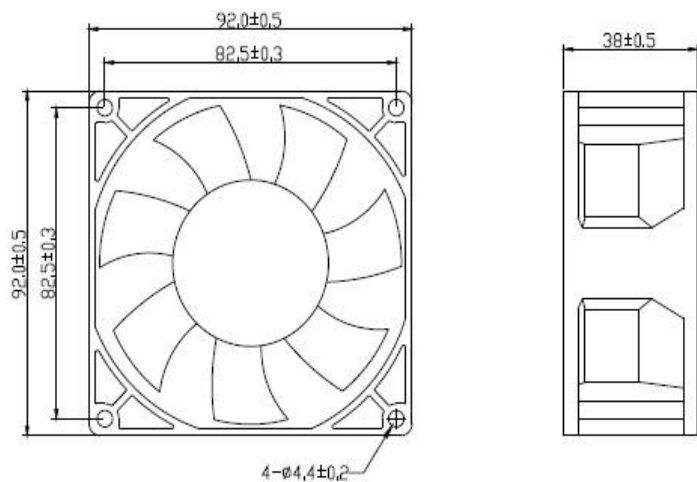

Unit: mm

- Performance:

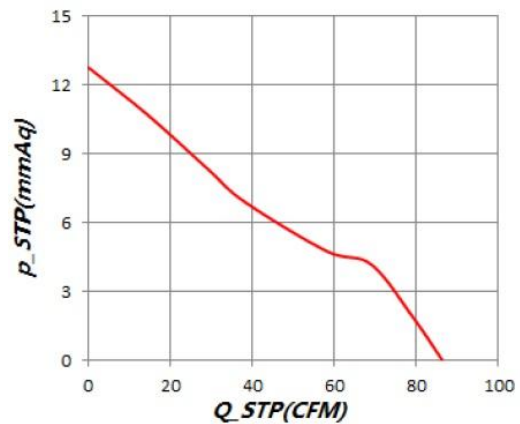

EC Axial Fan

120x120x25mm - C Type

- Housing: Thermoplastic PBT (UL94V-0)
- Impeller: Thermoplastic PBT (UL94V-0)
- Bearing: Ball Type
- Certification: CE, RoHS
- Additional functions are optional



Model	Voltage	Frequency	Power	Speed	Air Flow		Pressure		Noise
	VAC	Hz	Watt	RPM	CFM	m3/min	mmH2O	inH2O	dB(A)
AXE12025V1HB-N3	110	50/60	4.5	3000	93.6	2.66	8	0.31	49
AXE12025V2HB-N3	220	50/60	4.5	3000	93.6	2.66	8	0.31	49

EC Axial Fan

120x120x25mm - C Type

- Dimension:

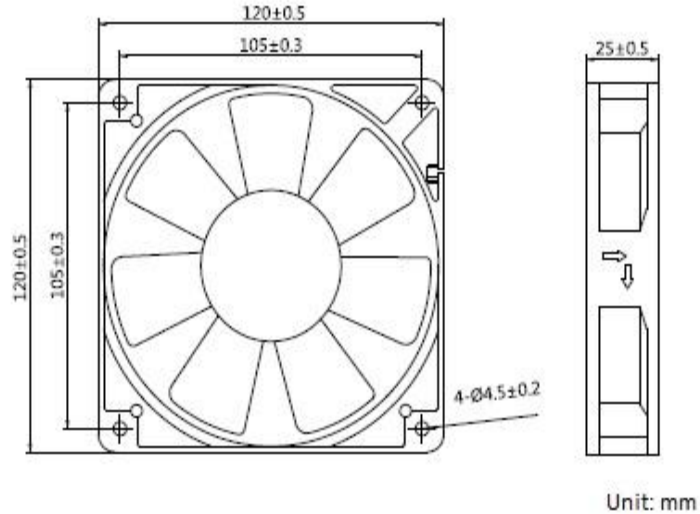

- Performance:

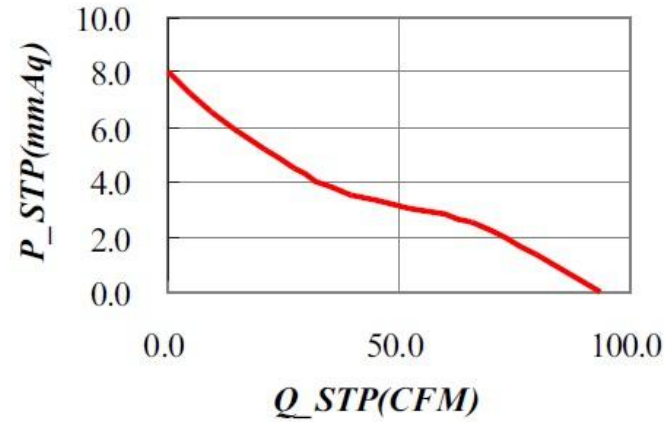

EC Axial Fan

120x120x38mm

- Housing: Thermoplastic PBT (UL94V-0)
- Impeller: Thermoplastic PBT (UL94V-0)
- Bearing: Ball Type
- Certification: CE, RoHS
- Additional functions are optional

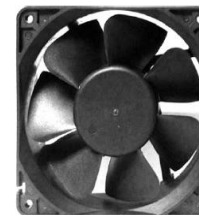

Model	Voltage	Frequency	Power	Speed	Air Flow		Pressure		Noise
	VAC	Hz	Watt	RPM	CFM	m3/min	mmH2O	inH2O	dB(A)
AXE12038V1HB-N	110	50/60	15	3500	133.82	3.8	13.1	0.52	52.4
AXE12038V2HB-N	220	50/60	15	3500	133.82	3.8	13.1	0.52	52.4

EC Axial Fan

120x120x38mm

- Dimension:

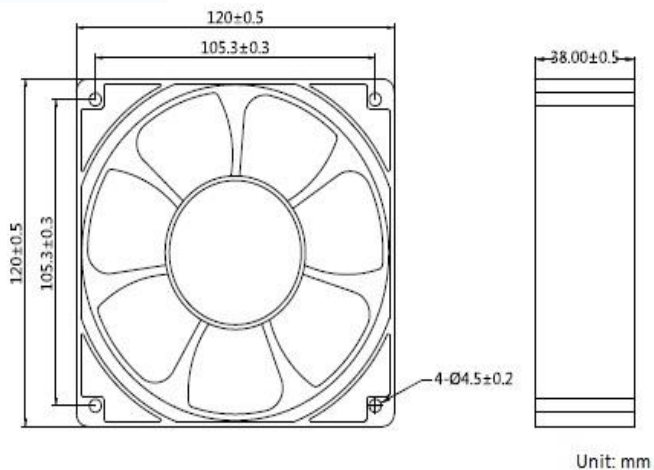

- Performance:

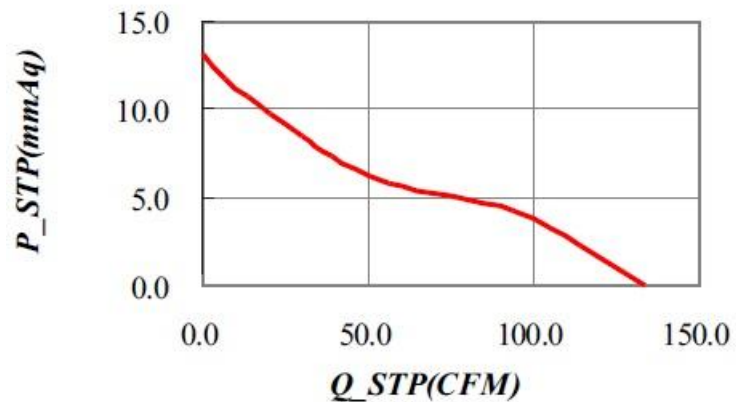

EC Axial Fan

120x120x38mm - C Type

- Housing: Thermoplastic PBT (UL94V-0)
- Impeller: Thermoplastic PBT (UL94V-0)
- Bearing: Ball Type
- Certification: CE, RoHS
- Additional functions are optional



Model	Voltage	Frequency	Power	Speed	Air Flow		Pressure		Noise
	VAC	Hz	Watt	RPM	CFM	m3/min	mmH2O	inH2O	dB(A)
AXE12038V1HB-N3	110	50/60	30	4500	2091	5.94	25.5	1	64.7
AXE12038V2HB-N3	220	50/60	30	4500	2091	5.94	25.5	1	64.7

EC Axial Fan

120x120x38mm - C Type

- Dimension:

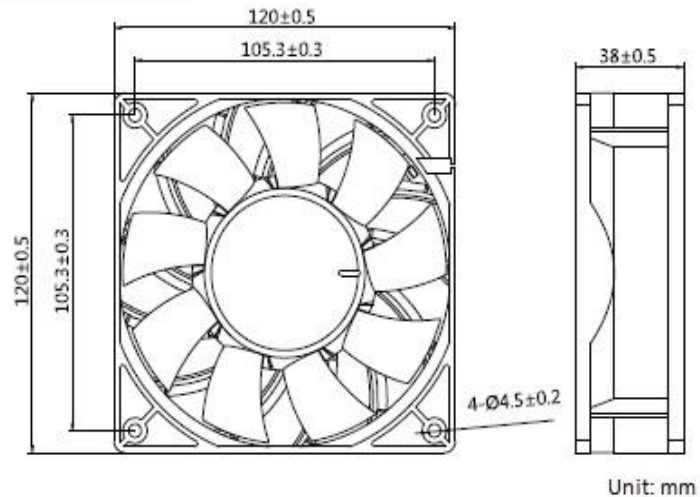

- Performance:

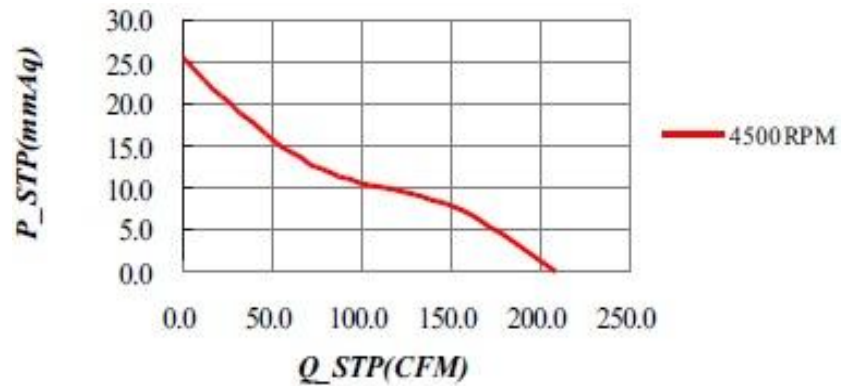

EC Axial Fan

120x120x38mm - E Type

- Housing: Thermoplastic PBT (UL94V-0)
- Impeller: Thermoplastic PBT (UL94V-0)
- Bearing: Ball Type
- Certification: CE, RoHS
- Additional functions are optional



Model	Voltage	Frequency	Power	Speed	Air Flow		Pressure		Noise
	VAC	Hz	Watt	RPM	CFM	m3/min	mmH2O	inH2O	dB(A)
AXE12038V1HB-K5	110	50/60	10.8	4000	135.75	3.801	15.84	0.624	56.6
AXE12038V2HB-K5	220	50/60	10.8	4000	135.75	3.801	15.84	0.624	56.6

EC Axial Fan

120x120x38mm - E Type

- Dimension:

Unit: mm

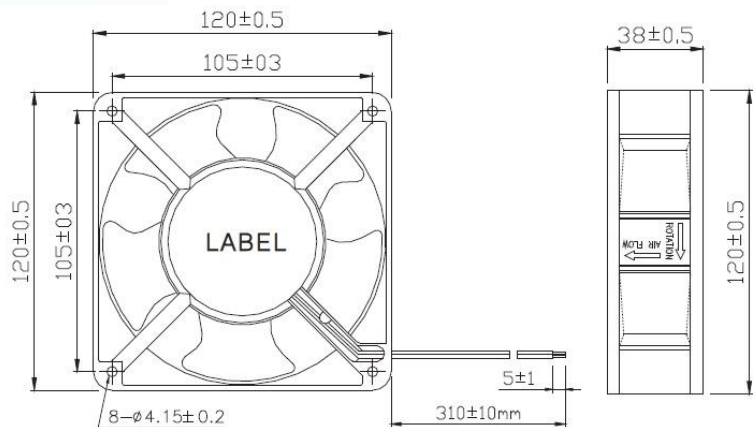

- Performance:

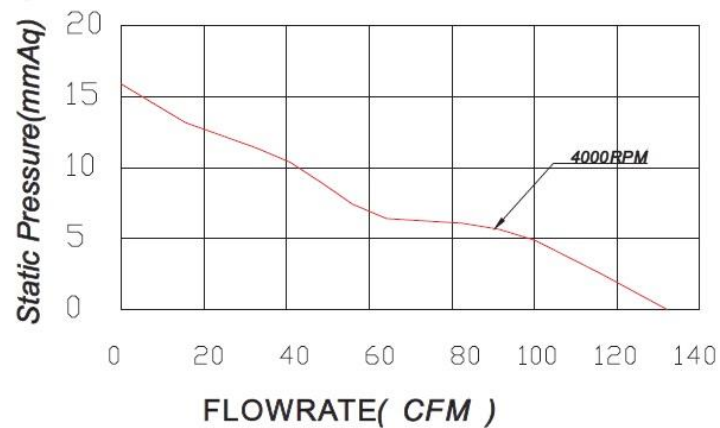

EC Axial Fan

140x140x25mm

- Housing: Thermoplastic PBT (UL94V-0)
- Impeller: Thermoplastic PBT (UL94V-0)
- Bearing: Ball Type
- Certification: CE, RoHS
- Additional functions are optional



Model	Voltage	Frequency	Power	Speed	Air Flow		Pressure		Noise
	VAC	Hz	Watt	RPM	CFM	m3/min	mmH2O	inH2O	dB(A)
AXE14025V1LB-N	110	50/60	4	1800	2.16	76.1	1.7	0.07	38.8
AXE14025V2LB-N	220	50/60	4	1800	2.16	76.1	1.7	0.07	38.8

EC Axial Fan

140x140x25mm

- Dimension:

Unit: mm

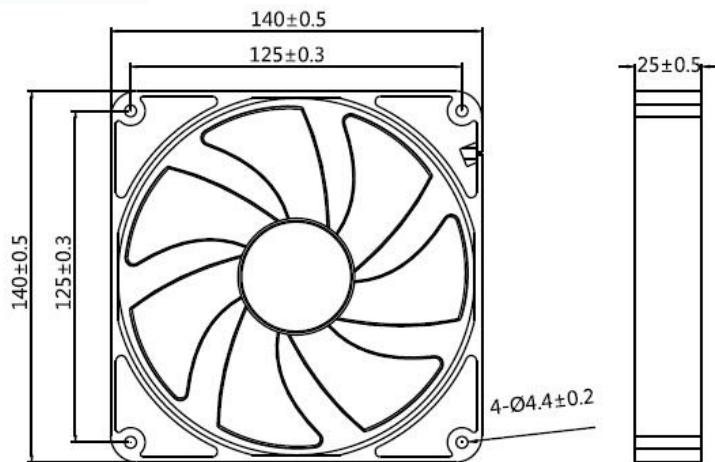

- Performance:

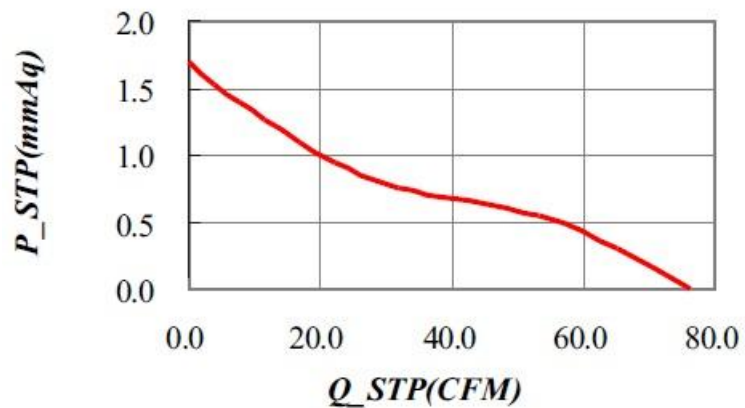

EC Axial Fan

150x150x50mm - B Type

- Housing: Thermoplastic PBT (UL94V-0)
- Impeller: Thermoplastic PBT (UL94V-0)
- Bearing: Ball Type
- Certification: CE, RoHS
- Additional functions are optional



Model	Voltage	Frequency	Power	Speed	Air Flow		Pressure		Noise
	VAC	Hz	Watt	RPM	CFM	m3/min	mmH2O	inH2O	dB(A)
AXE15050V1HB-N2	110	50/60	64	5000	375.4	10.66	35.4	1.39	71.2
AXE15050V2HB-N2	220	50/60	55	5000	375.4	10.66	35.4	1.39	71.2

EC Axial Fan

150x150x50mm - B Type

- Dimension:

Unit: mm

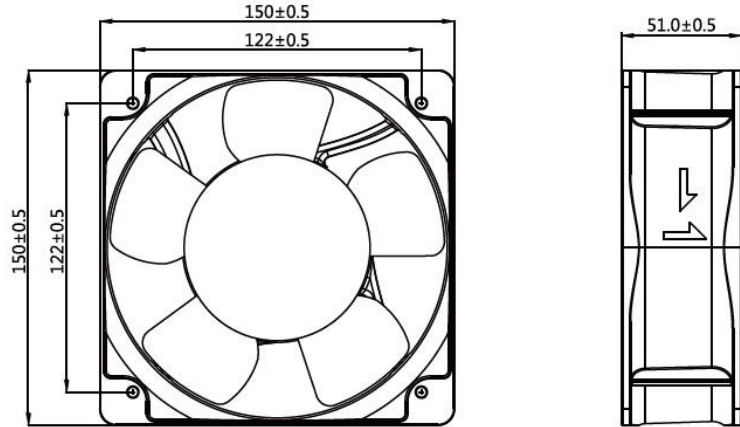

- Performance:

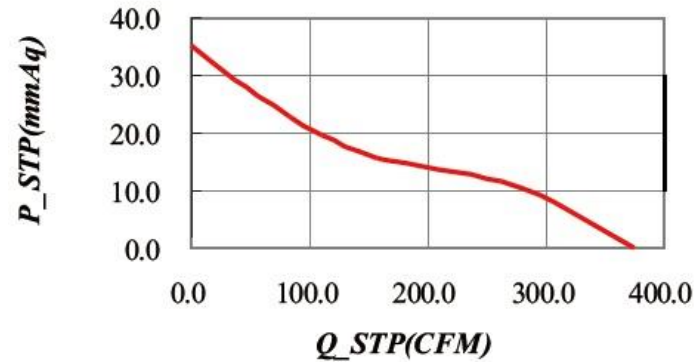

EC Axial Fan

171x153x51mm - B Type

- Housing: Thermoplastic PBT (UL94V-0)
- Impeller: Thermoplastic PBT (UL94V-0)
- Bearing: Ball Type
- Certification: CE, RoHS
- Additional functions are optional



Model	Voltage	Frequency	Power	Speed	Air Flow		Pressure		Noise
	VAC	Hz	Watt	RPM	CFM	m3/min	mmH2O	inH2O	dB(A)
AXE17151V1HB-N2	110	50/60	64	5000	371.86	10.53	38.17	1.5	69
AXE17151V2HB-N2	220	50/60	50	5000	371.86	10.53	38.17	1.5	69

EC Axial Fan

171x153x51mm - B Type

- Dimension:

Unit: mm

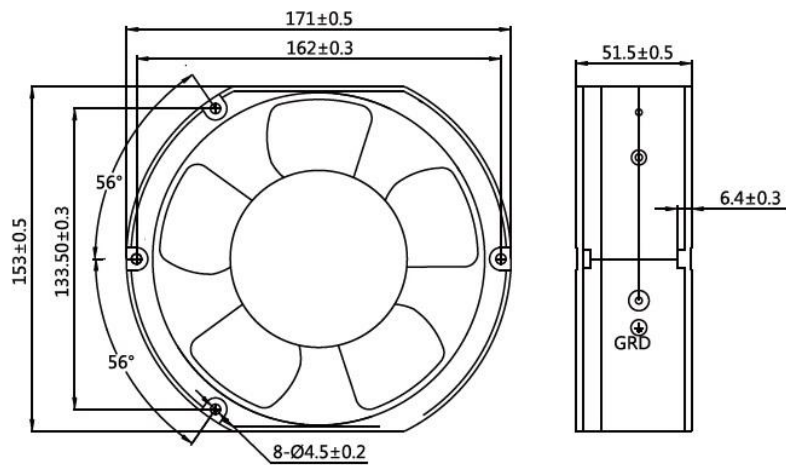

- Performance:

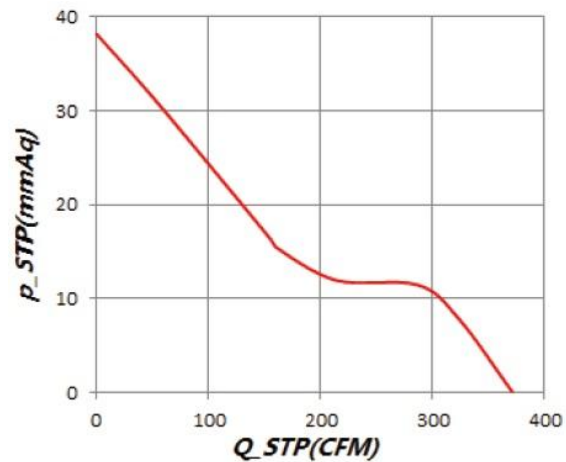

EC Axial Fan

172x151x51mm

- Housing: Aluminum
- Impeller: Thermoplastic PBT (UL94V-0)
- Bearing: Ball Type
- Certification: CE, RoHS
- Additional functions are optional



Model	Voltage	Frequency	Power	Speed	Air Flow		Pressure		Noise
	VAC	Hz	Watt	RPM	CFM	m3/min	mmH2O	inH2O	dB(A)
AXE17251V1HB-K	110	50/60	31.4	4200	306.1	8.571	31.3	1.23	66.2
AXE17251V2HB-K	220	50/60	31.4	4200	306.1	8.571	31.3	1.23	66.2

EC Axial Fan

172x151x51mm

- Dimension:

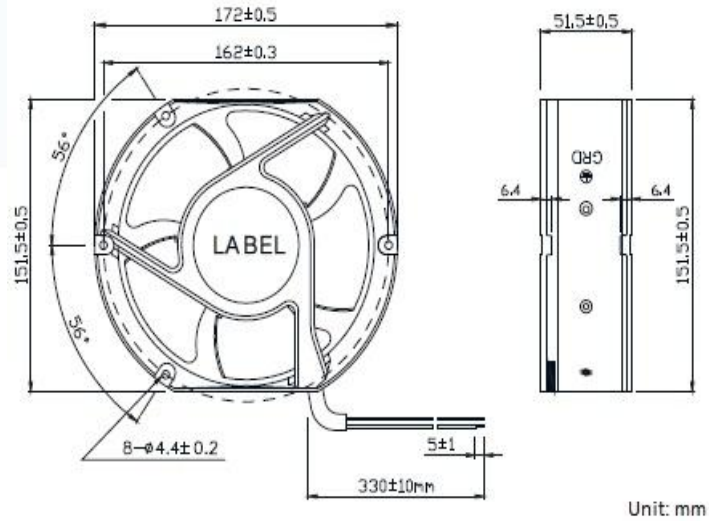

- Performance:

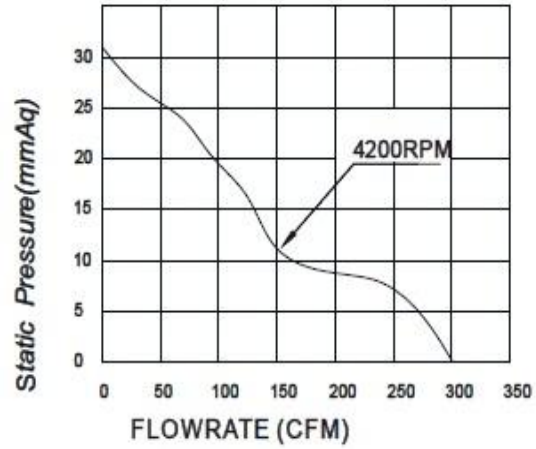

EC Axial Fan

200x200x60mm

- Housing: Aluminum
- Impeller: Thermoplastic PBT (UL94V-0)
- Bearing: Ball Type
- Certification: CE, RoHS
- Additional functions are optional



Model	Voltage	Frequency	Power	Speed	Air Flow		Pressure		Noise
	VAC	Hz	Watt	RPM	CFM	m3/min	mmH2O	inH2O	dB(A)
AXE20060V1LB-N	110	50/60	40	2000	324	9.17	10.62	0.42	58.6
AXE20060V1MB-N	110	50/60	50	2500	407.92	11.55	16.61	0.65	62.4
AXE20060V1HB-N	110	50/60	70	3000	492.43	13.94	22.69	0.89	68.5

EC Axial Fan

200x200x60mm

- Housing: Aluminum
- Impeller: Thermoplastic PBT (UL94V-0)
- Bearing: Ball Type
- Certification: CE, RoHS
- Additional functions are optional



Model	Voltage	Frequency	Power	Speed	Air Flow		Pressure		Noise
	VAC	Hz	Watt	RPM	CFM	m3/min	mmH2O	inH2O	dB(A)
AXE20060V2LB-N	220	50/60	40	2000	324	9.17	10.62	0.42	58.6
AXE20060V2MB-N	220	50/60	50	2500	407.92	11.55	16.61	0.65	62.4
AXE20060V2HB-N	220	50/60	70	3000	492.43	13.94	22.69	0.89	68.5

EC Axial Fan

200x200x60mm

- Dimension:
Unit: mm

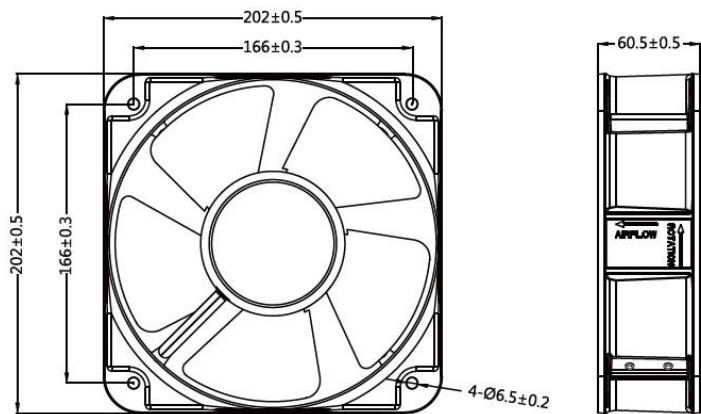

- Performance:

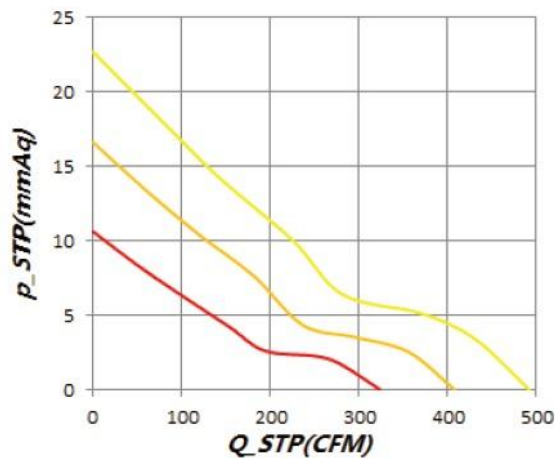

EC Axial Fan

206x206x72mm

- Housing: Aluminum
- Impeller: Thermoplastic PBT (UL94V-0)
- Bearing: Ball Type
- Certification: CE, RoHS
- Additional functions are optional



Model	Voltage	Frequency	Power	Speed	Air Flow		Pressure		Noise
	VAC	Hz	Watt	RPM	CFM	m3/min	mmH2O	inH2O	dB(A)
AXE20672V1HB-N	110	50/60	60	3000	583.01	16.52	28.11	1.11	65.5
AXE20672V2LB-N	220	50/60	60	3000	583.01	16.52	28.11	1.11	65.5

EC Axial Fan

206x206x72mm

- Dimension:
Unit: mm

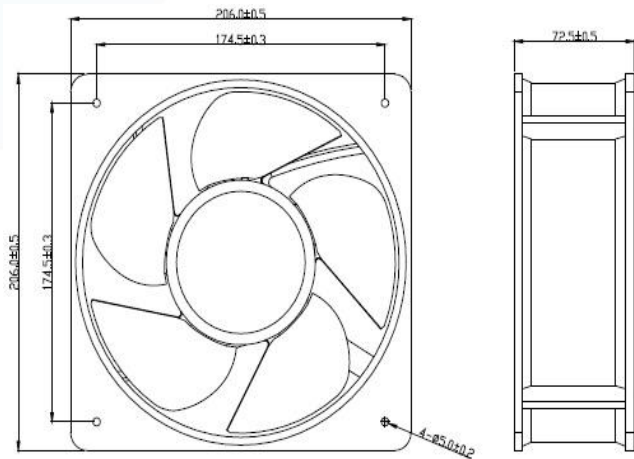

- Performance:

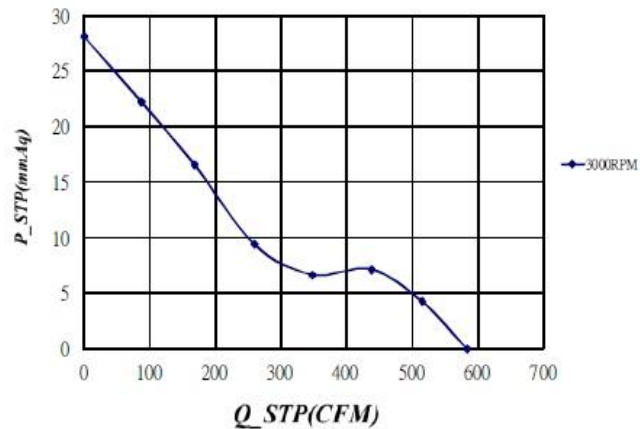

EC Axial Fan

Ø254x89mm

- Housing: Aluminum
- Impeller: Thermoplastic PBT (UL94V-0)
- Bearing: Ball Type
- Certification: CE, RoHS
- Additional functions are optional



Model	Voltage	Frequency	Power	Speed	Air Flow		Pressure		Noise
	VAC	Hz	Watt	RPM	CFM	m3/min	mmH2O	inH2O	dB(A)
AXE25489V1MB-N	110	50/60	60	2500	739.23	20.95	21.66	0.85	65.4
AXE25489V2MB-N	220	50/60	60	2500	739.23	20.95	21.66	0.85	65.4

EC Axial Fan

Ø254x89mm

- Dimension:

Unit: mm

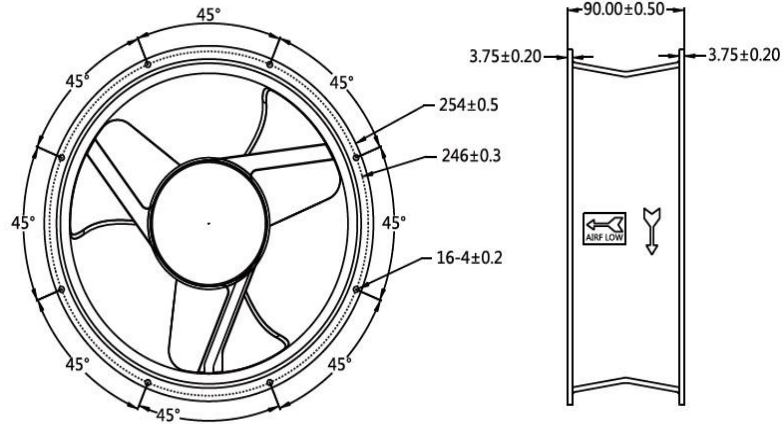

- Performance:

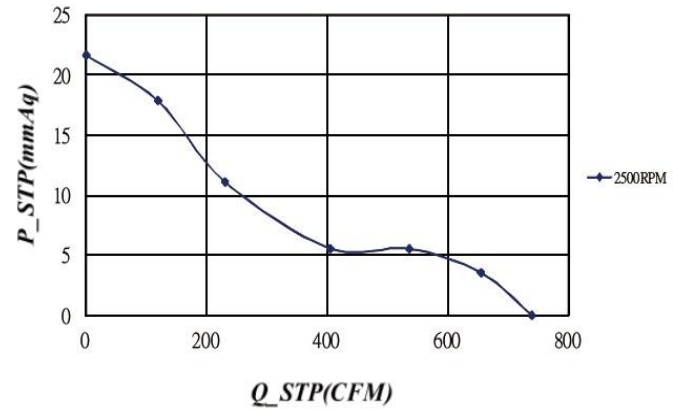

EC Axial Fan

280x280x90mm

- Housing: Aluminum
- Impeller: Thermoplastic PBT (UL94V-0)
- Bearing: Ball Type
- Certification: CE, RoHS
- Additional functions are optional



Model	Voltage	Frequency	Power	Speed	Air Flow		Pressure		Noise
	VAC	Hz	Watt	RPM	CFM	m3/min	mmH2O	inH2O	dB(A)
AXE28090V1MB-N	110	50/60	98	2500	1138.5	32.26	20.58	0.82	67.8
AXE28090V2MB-N	220	50/60	98	2500	1138.5	32.26	20.58	0.82	67.8

EC Axial Fan

280x280x90mm

- Dimension:

Unit: mm

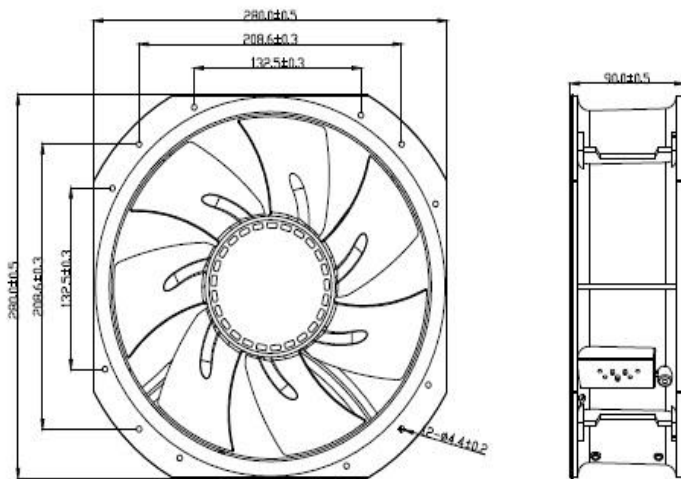

- Performance:

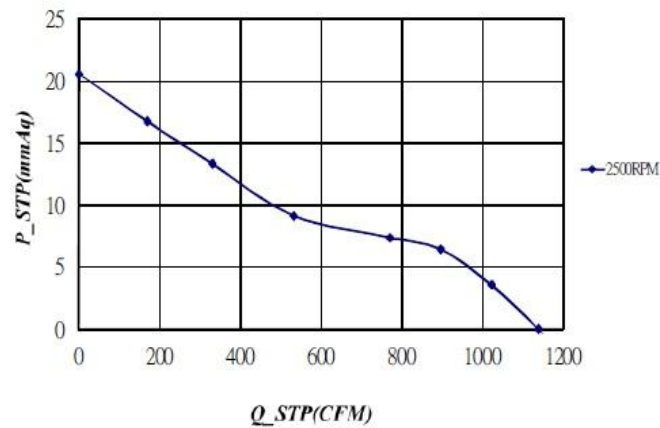

EC Axial Fan

Ø200x80mm

- Housing: Aluminum
- Impeller: Cold rolled steel sheet
- Protection: IP44
- Bearing: Ball Type
- Certification: CE, RoHS
- Additional functions are optional



Model	Voltage	Frequency	Power	Speed	Air Flow		Pressure		Noise
	VAC	Hz	Watt	RPM	CFM	m3/h	Pa	inH2O	dB(A)
OXE20080V2HB-M	230	50/60	70	3200	682.75	1160	320	1.28	68

EC Axial Fan

Ø200x80mm

- Dimension:

Unit: mm

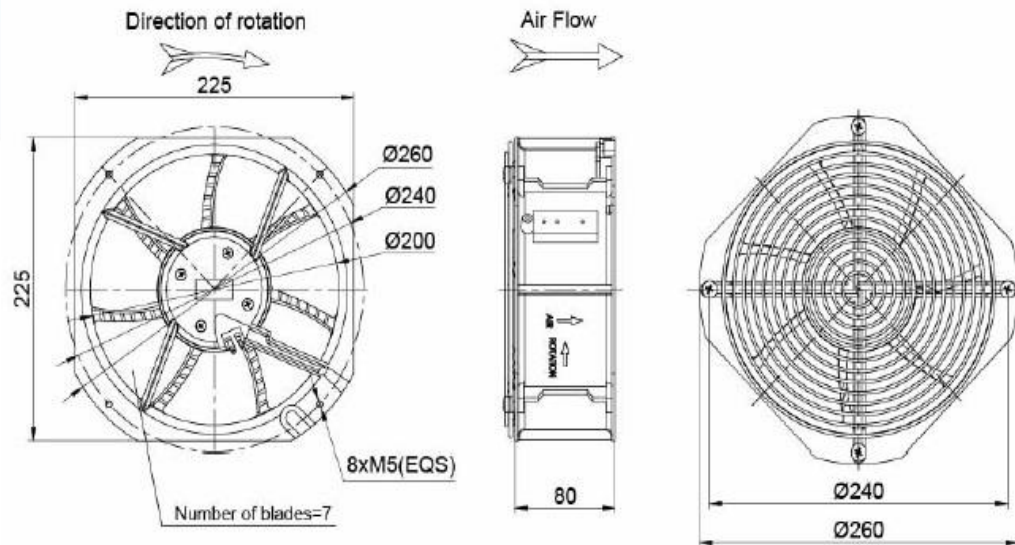

EC Axial Fan

Ø200x80mm

- Performance:

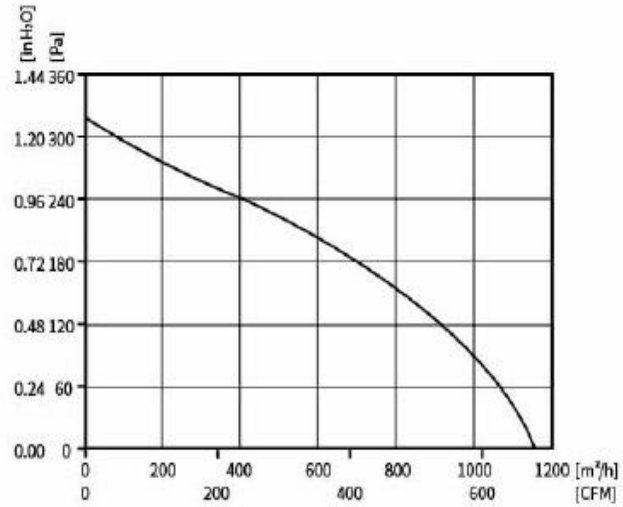

EC Axial Fan

Ø250x115mm

- Impeller: Cold rolled steel sheet
- Protection: IP44
- Bearing: Ball Type
- Certification: CE, RoHS
- Additional functions are optional



Model	Voltage	Frequency	Power	Speed	Air Flow		Pressure		Noise
	VAC	Hz	Watt	RPM	CFM	m3/h	Pa	inH2O	dB(A)
OXE250115V2HB-M	230	50/60	180	3000	1013.53	1722	268	1.07	75

EC Axial Fan

Ø250x115mm

- Dimension:

Unit: mm

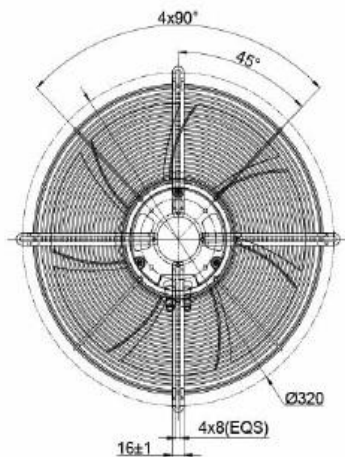
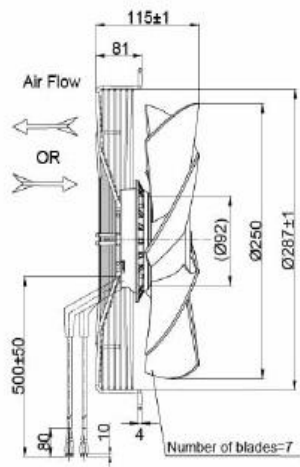

- Performance:

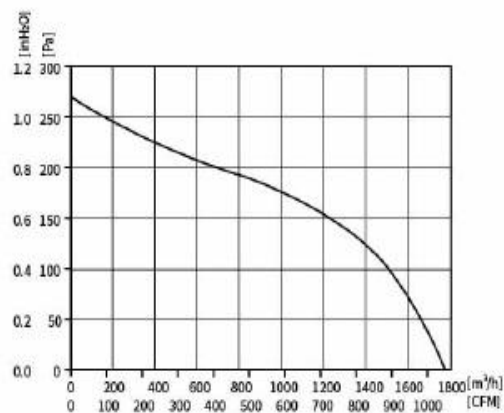

EC Axial Fan

Ø250x80mm

- Housing: Aluminum
- mpeller: Cold rolled steel sheet
- Protection: IP44
- Bearing: Ball Type
- Certification: CE, RoHS
- Additional functions are optional



Model	Voltage	Frequency	Power	Speed	Air Flow		Pressure		Noise
	VAC	Hz	Watt	RPM	CFM	m3/h	Pa	inH2O	dB(A)
OXE25080V2MB-M	230	50/60	80	2650	1035.89	1760	215	0.86	64

EC Axial Fan

Ø250x80mm

- Dimension:

Unit: mm

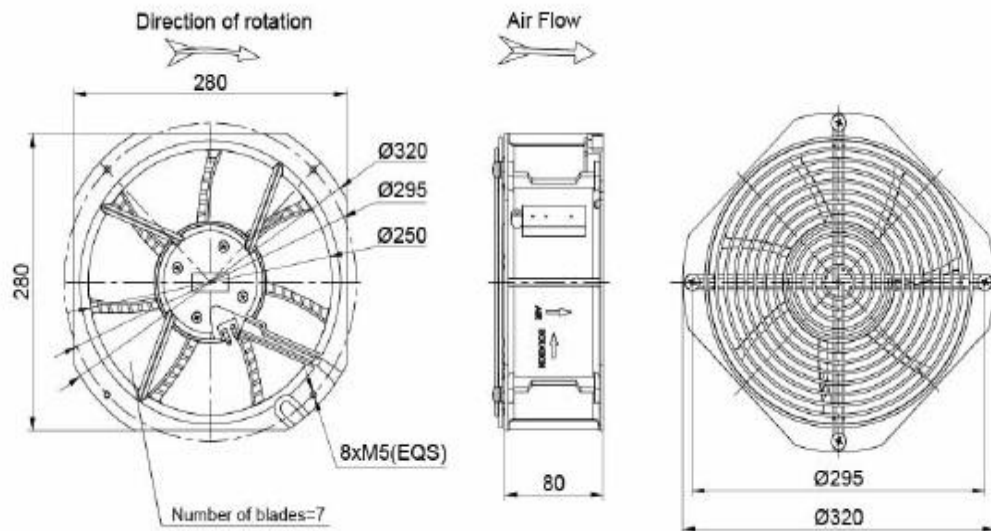

EC Axial Fan

Ø250x80mm

- Performance:

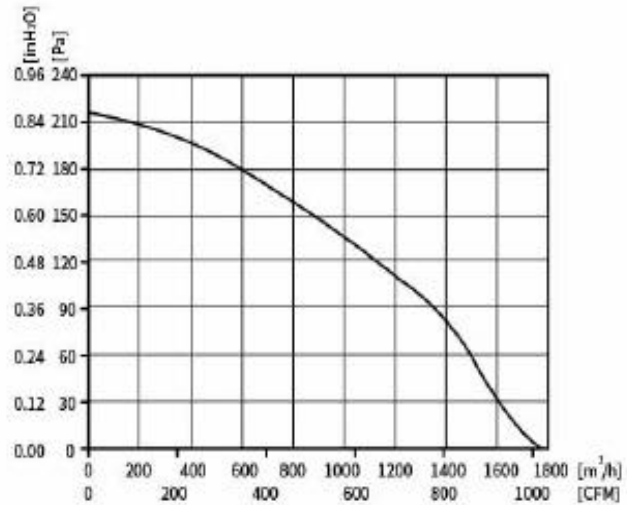

EC Axial Fan

Ø300x125mm

- Impeller: Cold rolled steel sheet
- Protection: IP44
- Bearing: Ball Type
- Certification: CE, RoHS
- Additional functions are optional



Model	Voltage	Frequency	Power	Speed	Air Flow		Pressure		Noise
	VAC	Hz	Watt	RPM	CFM	m3/h	Pa	inH2O	dB(A)
OXE300125V2LB-M	230	50/60	95	2000	1334.3	2267	214	0.85	71

EC Axial Fan

Ø300x125mm

- Dimension:

Unit: mm

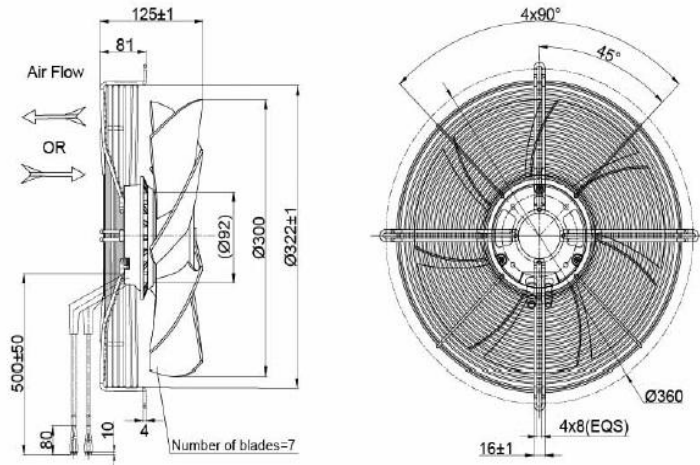

- Performance:

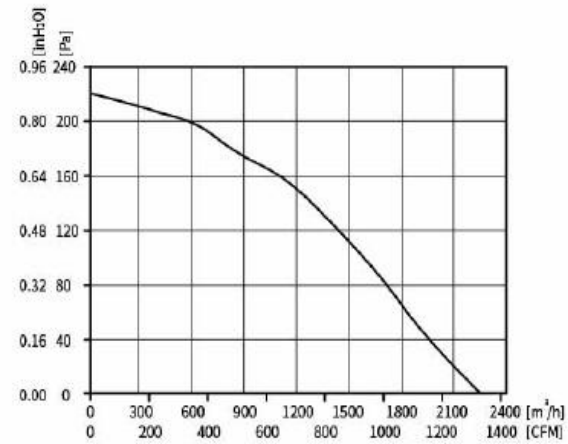

EC Axial Fan

Ø300x90mm

- Housing: Aluminum
- mpeller: Cold rolled steel sheet
- Protection: IP44
- Bearing: Ball Type
- Certification: CE, RoHS
- Additional functions are optional



Model	Voltage	Frequency	Power	Speed	Air Flow		Pressure		Noise
	VAC	Hz	Watt	RPM	CFM	m3/h	Pa	inH2O	dB(A)
OXE30090V2LB-M	230	50/60	95	2000	1334.3	2267	214	0.85	71

EC Axial Fan

Ø300x90mm

- Dimension:

Unit: mm

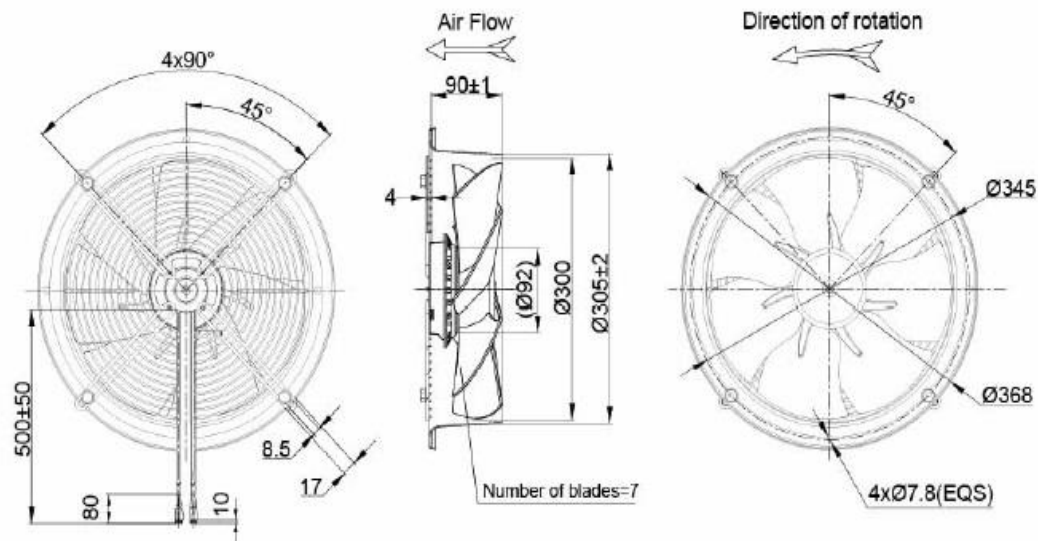

EC Axial Fan

Ø300x90mm

- Performance:

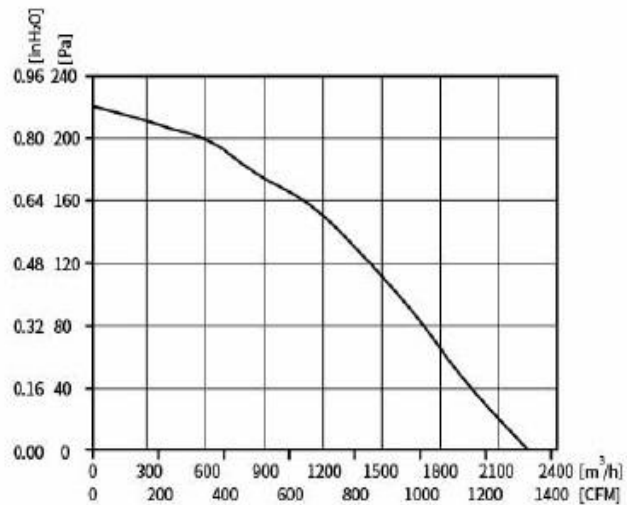

EC Axial Fan

Ø350x100mm

- Impeller: Cold rolled steel sheet
- Protection: IP44
- Bearing: Ball Type
- Certification: CE, RoHS
- Additional functions are optional



Model	Voltage	Frequency	Power	Speed	Air Flow		Pressure		Noise
	VAC	Hz	Watt	RPM	CFM	m3/h	Pa	inH2O	dB(A)
OXE350100V2LB-M	230	50/60	230	1580	1889.33	3210	150	0.6	63

EC Axial Fan

Ø350x100mm

- Dimension:

Unit: mm

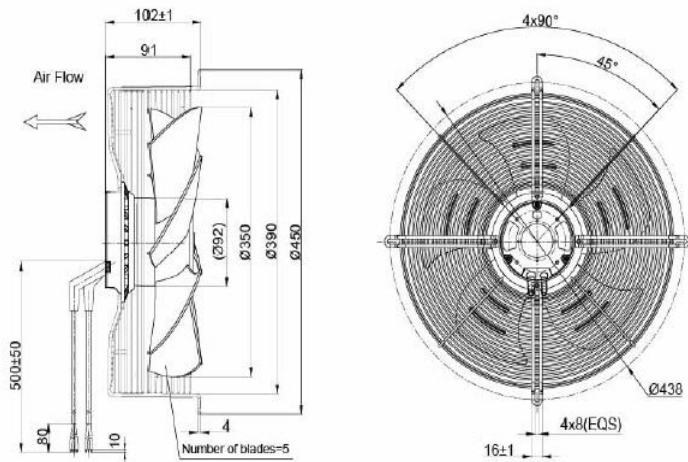

- Performance:

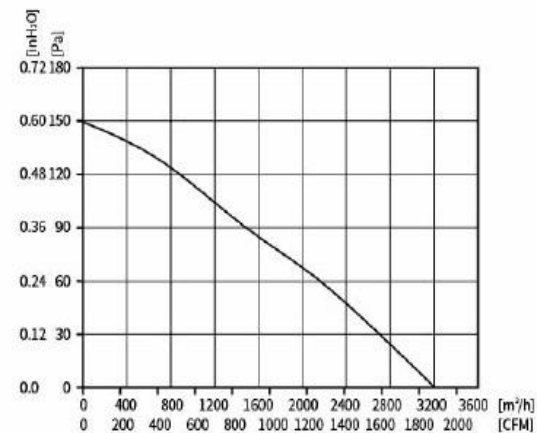

EC Axial Fan

Ø400x140mm

- Impeller: Cold rolled steel sheet
- Protection: IP44
- Bearing: Ball Type
- Certification: CE, RoHS
- Additional functions are optional



Model	Voltage	Frequency	Power	Speed	Air Flow		Pressure		Noise
	VAC	Hz	Watt	RPM	CFM	m3/h	Pa	inH2O	dB(A)
OXE400140V2LB-M	230	50/60	400	1700	3060.6	5200	250	1	67

EC Axial Fan

Ø400x140mm

- Dimension:

Unit: mm

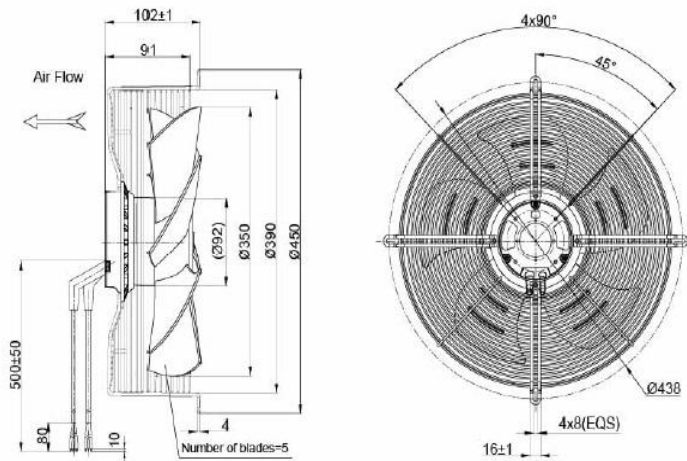

- Performance:

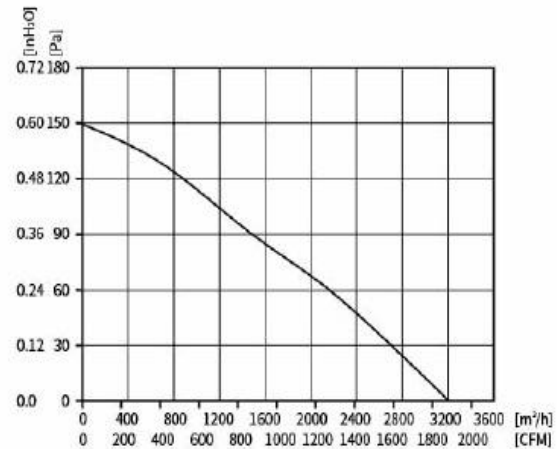

EC Axial Fan

Ø450x140mm

- Impeller: Cold rolled steel sheet
- Protection: IP44
- Bearing: Ball Type
- Certification: CE, RoHS
- Additional functions are optional



Model	Voltage	Frequency	Power	Speed	Air Flow		Pressure		Noise
	VAC	Hz	Watt	RPM	CFM	m3/h	Pa	inH2O	dB(A)
OXE450140V2LB-M	230	50/60	400	1750	3532.05	6001	316	1.26	76

EC Axial Fan

Ø450x140mm

- Dimension:

Unit: mm

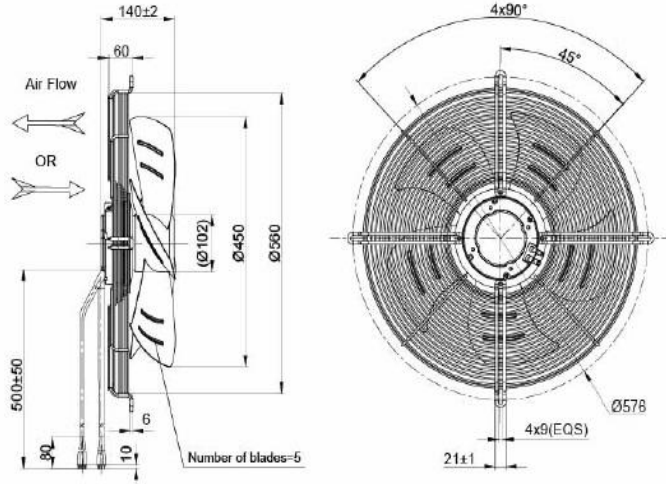

- Performance:

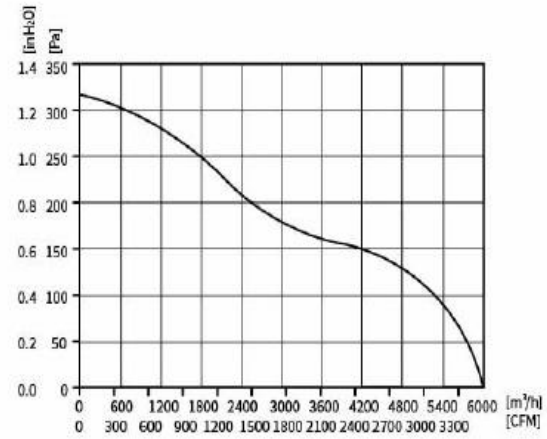

EC Axial Fan

Ø450x142mm

- Impeller: Cold rolled steel sheet
- Protection: IP44
- Bearing: Ball Type
- Certification: CE, RoHS
- Additional functions are optional



Model	Voltage	Frequency	Power	Speed	Air Flow		Pressure		Noise
	VAC	Hz	Watt	RPM	CFM	m3/h	Pa	inH2O	dB(A)
OXE450142V2LB-M	230	50/60	400	1700	3578.55	6080	270	1.08	70

EC Axial Fan

Ø450x142mm

- Dimension:

Unit: mm

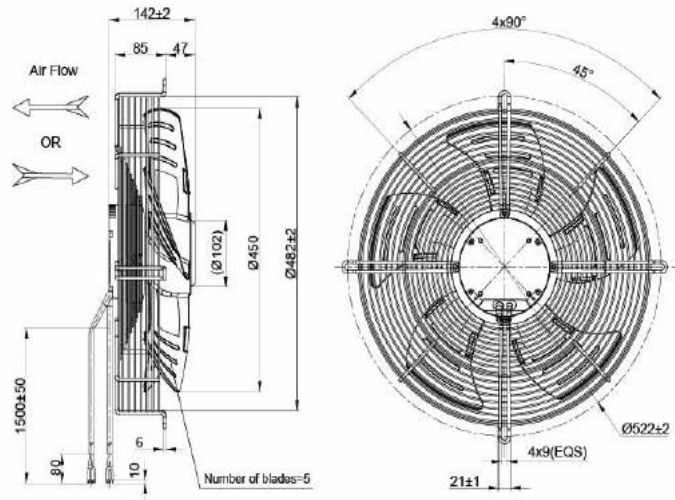

- Performance:

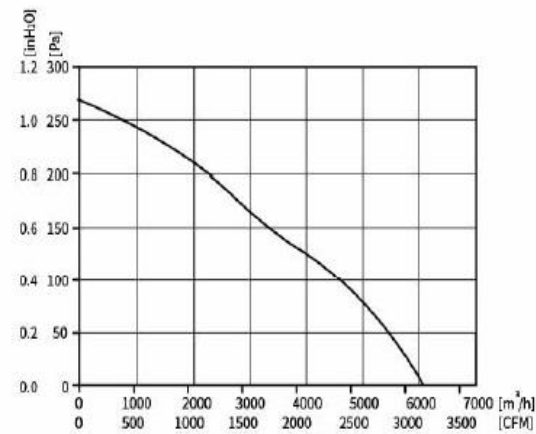

EC Axial Fan

Ø500x182mm

- Impeller: Cold rolled steel sheet
- Protection: IP44
- Bearing: Ball Type
- Certification: CE, RoHS
- Additional functions are optional



Model	Voltage	Frequency	Power	Speed	Air Flow		Pressure		Noise
	VAC	Hz	Watt	RPM	CFM	m3/h	Pa	inH2O	dB(A)
OXE500182V2LB-M	230	50/60	600	1450	5002.91	8500	260	1.04	71

EC Axial Fan

Ø500x182mm

- Dimension:

Unit: mm

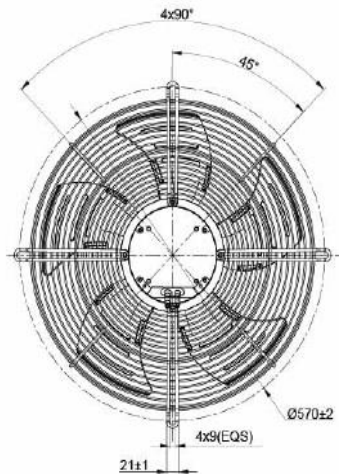
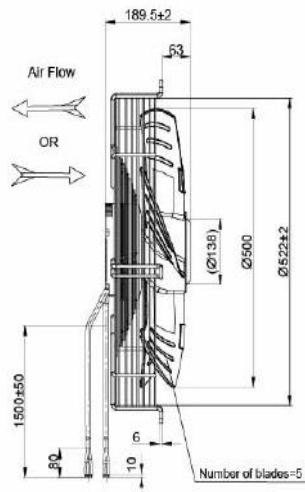

- Performance:

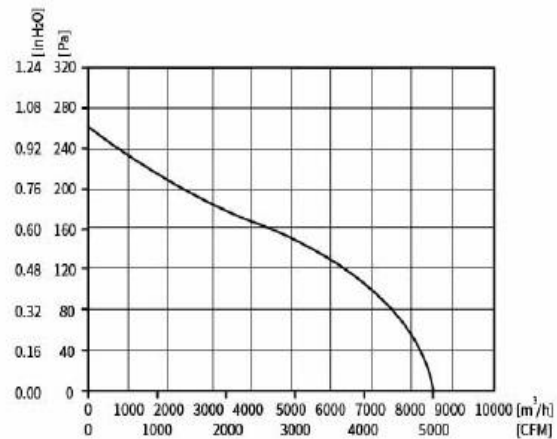

EC Axial Fan

Ø500x182mm - B Type

- Impeller: Cold rolled steel sheet
- Protection: IP44
- Bearing: Ball Type
- Certification: CE, RoHS
- Additional functions are optional



Model	Voltage	Frequency	Power	Speed	Air Flow		Pressure		Noise
	VAC	Hz	Watt	RPM	CFM	m3/h	Pa	inH2O	dB(A)
OXE500182V2LB-M2	230	50/60	850	1690	5668	9630	550	2.2	78

EC Axial Fan

Ø500x182mm - B Type

- Dimension:

Unit: mm

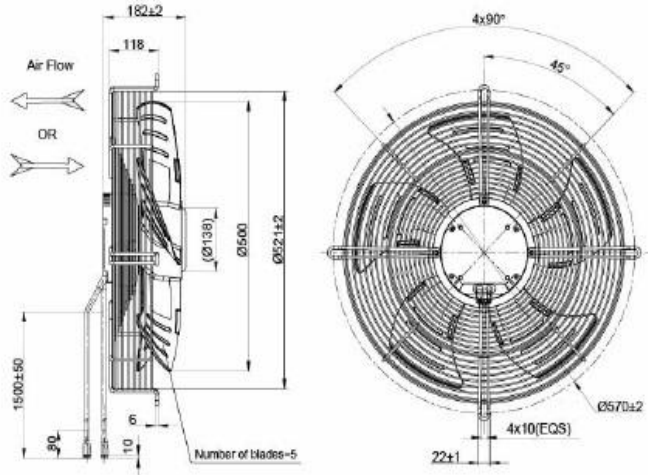

- Performance:

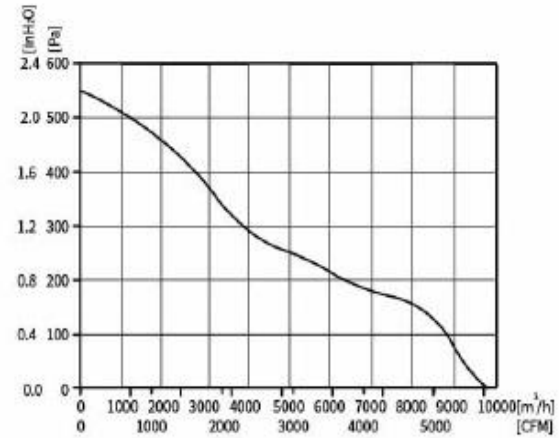

EC Axial Fan

Ø550x182mm

- Impeller: Cold rolled steel sheet
- Protection: IP44
- Bearing: Ball Type
- Certification: CE, RoHS
- Additional functions are optional



Model	Voltage	Frequency	Power	Speed	Air Flow		Pressure		Noise
	VAC	Hz	Watt	RPM	CFM	m3/h	Pa	inH2O	dB(A)
OXE550182V2LB-M	230	50/60	950	1690	7062.93	12000	270	1.08	78

EC Axial Fan

Ø550x182mm

- Dimension:

Unit: mm

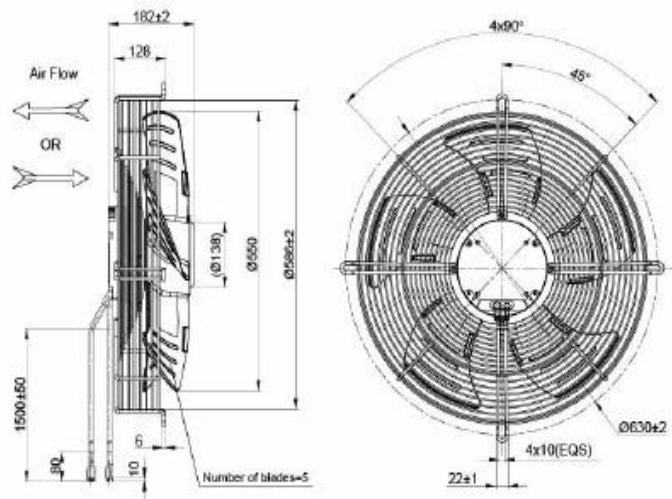

- Performance:

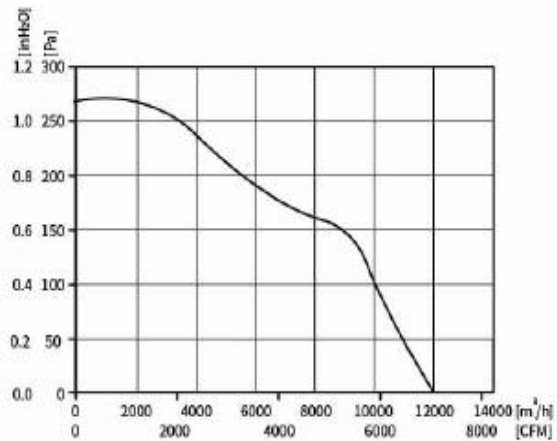

EC Axial Fan

Ø630x182mm

- Impeller: Cold rolled steel sheet
- Protection: IP44
- Bearing: Ball Type
- Certification: CE, RoHS
- Additional functions are optional



Model	Voltage	Frequency	Power	Speed	Air Flow		Pressure		Noise
	VAC	Hz	Watt	RPM	CFM	m3/h	Pa	inH2O	dB(A)
OXE630182V2LB-M	230	50/60	800	1150	8534.37	14500	240	0.96	69

EC Axial Fan

Ø630x182mm

- Dimension:
Unit: mm

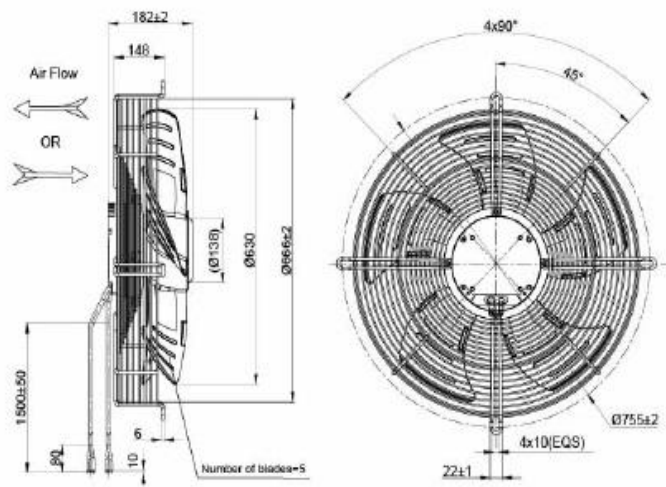

- Performance:

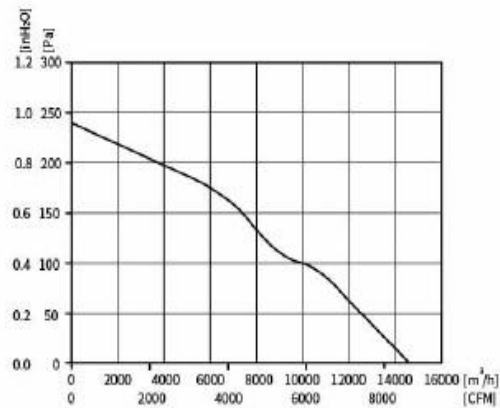



Change is a perpetual motion

Phone: +886-7-215-0001

Mobile: +886-938-016696

E-mail: service@cainton.com

Address: 9F.-1, No. 171,
Bizhong St., Yancheng Dist.,
Kaohsiung City 803002, Taiwan (R.O.C.)

www.cainton.com